

# Pregio

## Workshop Manual

### FOREWORD

This Workshop Manual provides information covering normal service, repairs, and maintenance for all systems of the Pregio.

This manual is organised into Groups covering general systems. Within each Group, the information is further divided into Sections. There is one Section for each component or sub-system. Some Groups contain a Service Section to cover procedures common to several components or subsystems within the Group. In general, each Section contains an Outline Description, Troubleshooting, Adjustments, Removal, Installation, Disassembly, Assembly and Inspection procedures for the component covered in the Section. Diagnosis and Testing is included in the first section of some Groups to help you systematically locate and correct problems encountered. In most cases, Specifications are included at the end of each Section.

To aid in locating specific subjects in this manual, use the Table of Contents on the following pages.

As a further aid, there is an index on the first page of each Group which lists the Section title for each component covered within the group.

This Group Section breakdown is also indicated in the page number located at the top of each page.

Example: 42A-35 = (Group) 42A, (Page) 35.

The descriptions and specifications contained in this manual were in effect at the time this manual was approved for printing. Kia Motors Corporation reserves the right to discontinue models at any time, or change specifications or design without notice and without incurring obligation.

Kia Motors Corporation  
SEOUL, KOREA

### CONTENTS

Title	Group
General Information	00
Engine(J2 Engine)	10A
Engine(JTA Engine)	10B
Lubrication System(J2 Engine)	11A
Lubrication System(JTA Engine)	11B
Cooling System(J2 Engine)	12A
Cooling System(JTA Engine)	12B
Intake and Exhaust System(J2 Engine)	20A
Intake and Exhaust System(JTA Engine)	20B
Fuel System(J2 Engine)	22A
Fuel System(JTA Engine)	22B
Starting System(J2 Engine)	31A
Starting System(JTA Engine)	31B
Charging System(J2 Engine)	41A
Charging System(JTA Engine)	41B
Clutch	40
Manual Transmission	
Automatic Transmission	
Propeller shaft	45
Front and Rear Axle	50
Steering System	51
Brake System	52
Wheels and Tires	53
Suspension	54
Body	60
Body Electrical System	61
Air Conditioner	62

## WARNING

Appropriate service methods and proper repair procedures are essential for the safe, reliable operation of all motor vehicles as well as the personal safety of the individual doing the repair. There are numerous variations in procedures, techniques, tools, and parts for servicing vehicles, as well as in the skill of the individual doing the work. This manual cannot possibly anticipate all such variations and provide advice or caution to each. Accordingly, anyone who departs from the instruction provided in this manual must first establish that he compromises neither his personal safety nor the vehicle integrity by his choice of methods, tools, or parts. The following list contains general warnings that should always be followed while working on a vehicle.

- Always wear safety glasses for eye protection.
- Use safety stands whenever a procedure requires underbody work.
- Be sure ignition switch is always off unless otherwise specified by a procedure.
- Set the parking brake when working on the vehicle.
- Operate the engine only in a well ventilated area.
- Keep clear of moving parts when engine is running.
- To prevent serious burns, avoid contact with hot metal parts such as the radiator, exhaust manifold, tail pipe, catalytic converter and muffler.
- Do not smoke while working on a vehicle.

## CAUTION

Severe engine and transaxle damage may result from the use of poor quality fuels and lubricants that do not meet Kia specifications. You must always use high quality fuels and lubricants that meet the specifications described on the specification section in the relevant group of the Workshop Manual.

# GENERAL INFORMATION







00

ABBREVIATIONS .....	00- 9
FUNDAMENTAL PROCEDURES .....	00- 3
IDENTIFICATION NUMBER LOCATIONS .....	00- 9
JACK AND SAFETY STAND POSITIONS .....	00- 7
TOWING .....	00- 8
UNITS .....	00- 9
VEHICLE LIFT (2-SUPPORT TYPE) POSITIONS .....	00- 7

## FUNDAMENTAL PROCEDURES

### SYMBOLS

There are six symbols indicating oil, grease, and sealant. These symbols show the points of applying such materials during service.

Symbol	Meaning	Kind
	Apply oil	New engine oil or gear oil as appropriate
	Apply brake fluid	Only brake fluid
	Apply automatic transaxle fluid	Only ATF
	Apply grease	Appropriate grease
	Apply sealant	Appropriate sealant
	Apply petroleum jelly	Appropriate

#### Note

- When special oil or grease is needed, this is shown in the illustration.

### NOTES, CAUTIONS, AND WARNINGS

As you read through the procedures, you will come across NOTES, CAUTIONS, and WARNINGS. Each one is there for a specific purpose. NOTES give you added information that will help you to complete a particular procedure. CAUTIONS are given to prevent you from making an error that could damage the vehicle. WARNINGS remind you to be especially careful in those areas where carelessness can cause personal injury. The following list contains some general WARNINGS you should follow when you work on a vehicle.

### PROTECTION OF THE VEHICLE

Always be sure to cover fenders, seats, and floor areas before starting work.

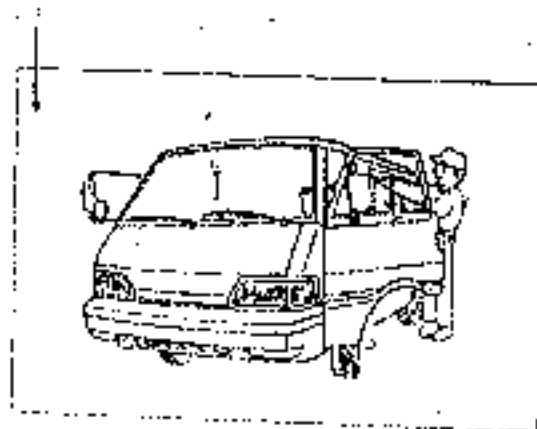

## 00-4 GENERAL INFORMATION FUNDAMENTAL PROCEDURES

### A WORD ABOUT SAFETY

The following precautions must be followed when jacking up the vehicle.

1. Block the wheels.
2. Use only the specified jacking positions.
3. Support the vehicle with safety stands.

Start the engine only after making certain the engine compartment is clear of tools and people.

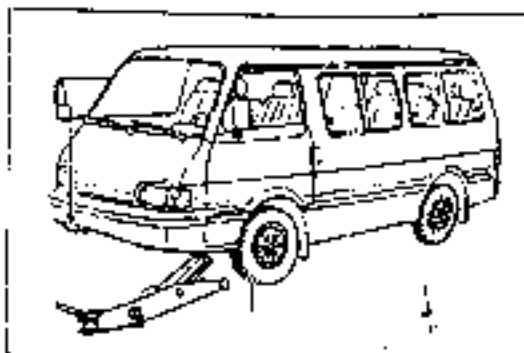

AP2000002

### PREPARATION OF TOOLS AND MEASURING EQUIPMENT

Be sure that all necessary tools and measuring equipment are available before starting any work.

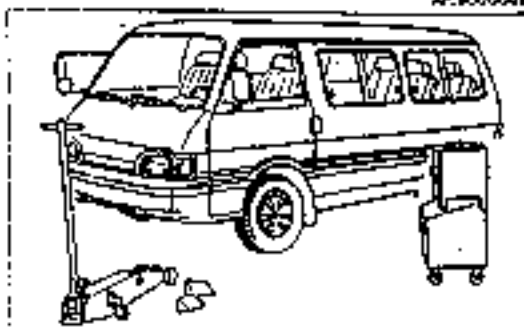

AN2000003

### SPECIAL TOOLS

Use special tools when they are required.

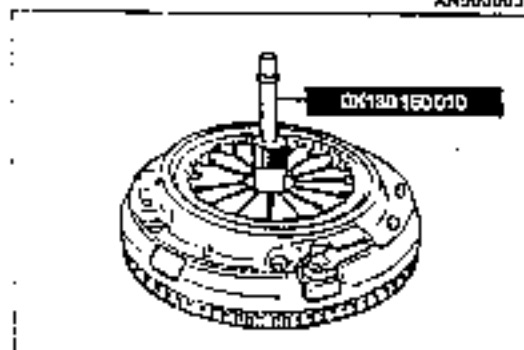

DSX000004

### REMOVAL OF PARTS

While correcting a problem, try also to determine its cause.

Begin work only after first learning which parts and subassemblies must be removed and disassembled for replacement or repair.

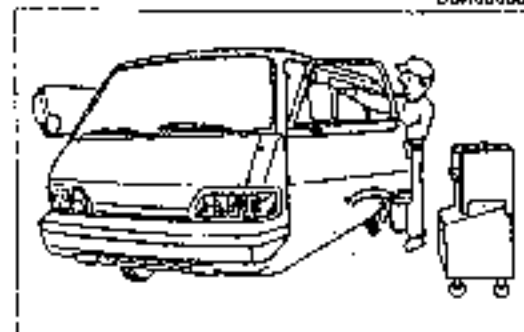

AH2000004

### DISASSEMBLY

If the disassembly procedure is complex, requiring many parts to be disassembled, all parts should be disassembled in a way that will not affect their performance or external appearance and identified so that reassembly can be performed easily and efficiently.

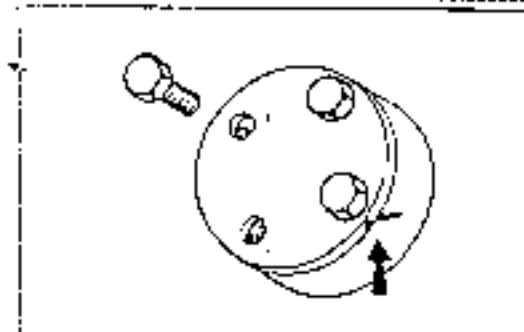

BSX000006

**INSPECTION OF PARTS**

When removed, each part should be carefully inspected for malfunctioning, deformation, damage, and other problems.

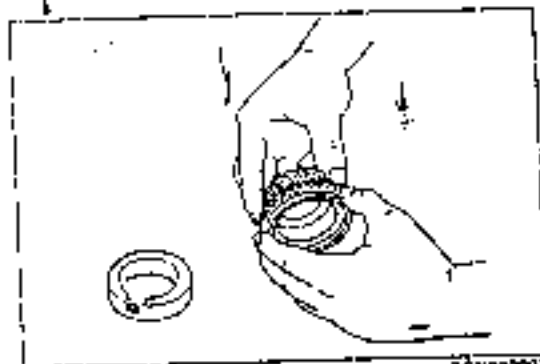

BSX00007

**ARRANGEMENT OF PARTS**

All disassembled parts should be carefully arranged for re-assembly.

Be sure to separate or otherwise identify the parts to be replaced from those that will be reused.

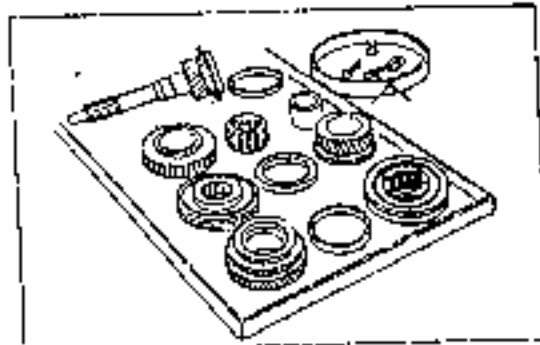

BSX00008

**CLEANING PARTS FOR REUSE**

All parts to be reused should be carefully and thoroughly cleaned in the appropriate method.

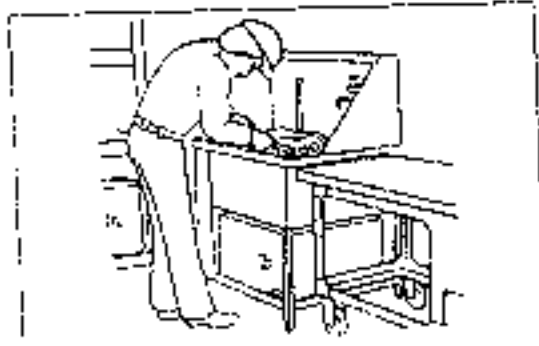

BSX00009

**REASSEMBLY**

Standard values, such as torques and certain adjustments, must be strictly observed in the reassembly of all parts.

If removed, these parts should be replaced with new ones:

- |                |                 |
|----------------|-----------------|
| 1. Oil seals   | 2. Gaskets      |
| 3. O-rings     | 4. Lock washers |
| 5. Cotter pins | 6. Nylon nuts   |

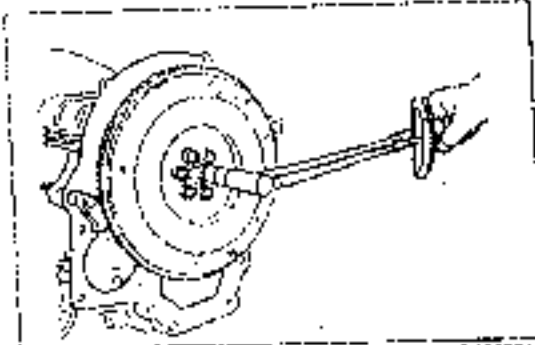

BSX00010

**Depending on location :**

1. Sealant should be applied or new gaskets used.
2. Oil should be applied to the moving components of parts.
3. Specified oil or grease should be applied at the prescribed locations (such as oil seals) before reassembly.

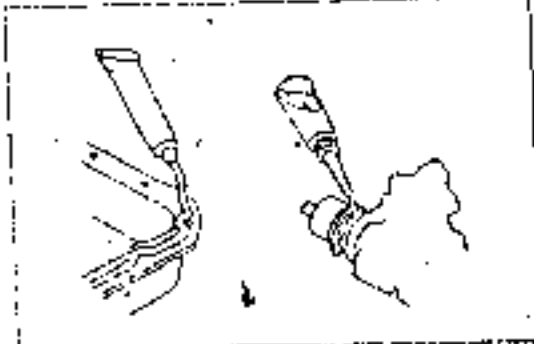

BSX00011

**ADJUSTMENTS**

Use suitable gauges and/or testers when making adjustments.

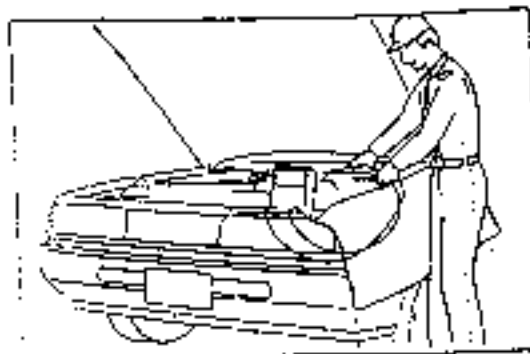

BSX000012

**RUBBER PARTS AND TUBING**

Prevent gasoline or oil from getting on rubber parts or tubing.

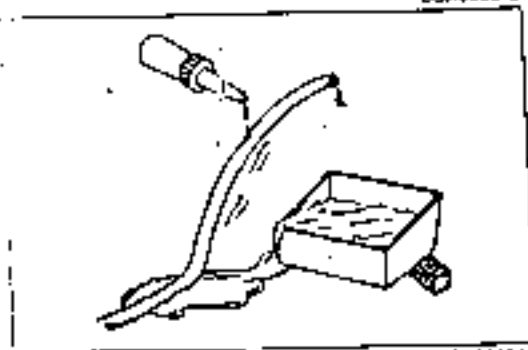

BEX000014

## JACK AND SAFETY STAND POSITION

### FRONT END

Jack position :  
At the front crossmember

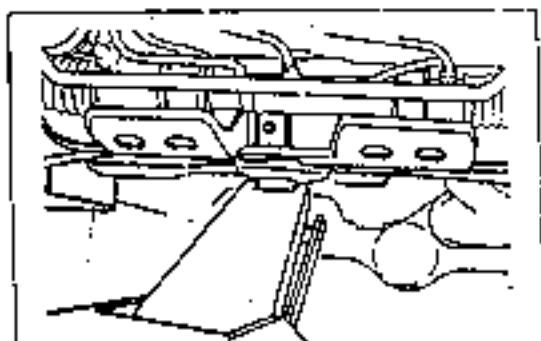

AN9000005

Safety stand positions :  
On both sides of the body frame

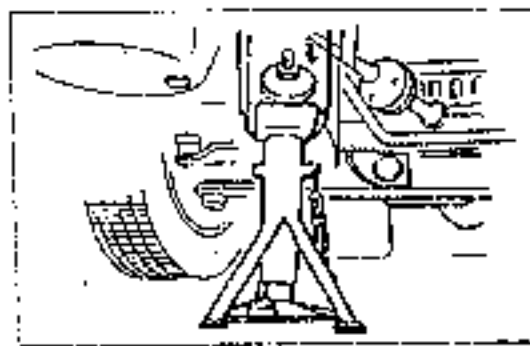

AN9000007

### REAR END

Jack position :  
At the center of the axle housing

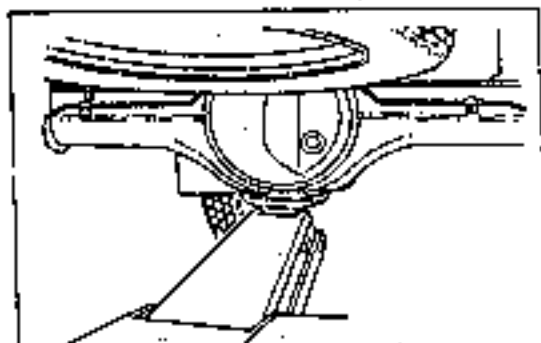

AN9000008

Safety stand position :  
On both sides of the axle housing

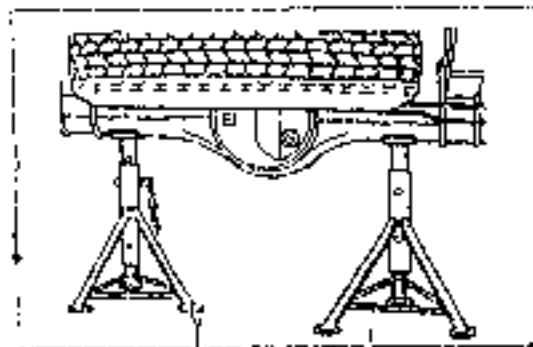

AN9000009

## VEHICLE LIFT (2-SUPPORT TYPE) POSITIONS

### FRONT END

Side sills

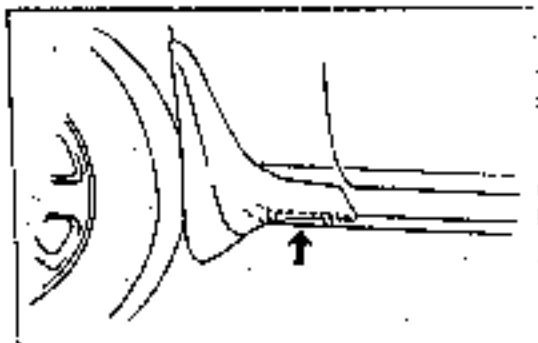

AGX000004

### REAR END

Side sills

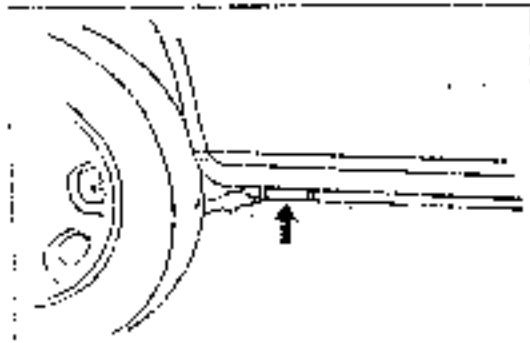

AGX000006



## 00-8 GENERAL INFORMATION TOWING

### TOWING

Proper towing equipment is necessary to prevent damage to the vehicle during any towing operation.

Laws and regulations applicable to vehicles in tow must always be observed.

As a rule, towed vehicles should be pulled with all four wheels off the ground.



With either automatic or manual transaxle:

1. Set the ignition switch in the ACC position.
2. Place the selector lever or shift lever in N (neutral).
3. Release the parking brake.

AN000000

#### Caution

- The power assist for the brakes and steering are inoperable while the engine is off.
- Do not use the hook loops under the front or rear of the vehicle for towing. These hook loops are designed **ONLY** for transport tiedown. If tiedown hook loops are used for towing the front or rear skirt and bumper will be damaged.

## IDENTIFICATION NUMBER LOCATIONS

## ENGINE MODEL NUMBER

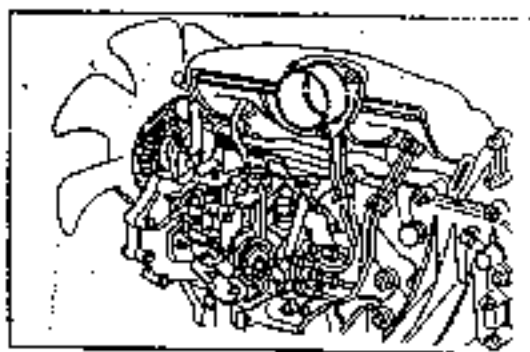

A76900011

## VEHICLE IDENTIFICATION NUMBER (VIN)

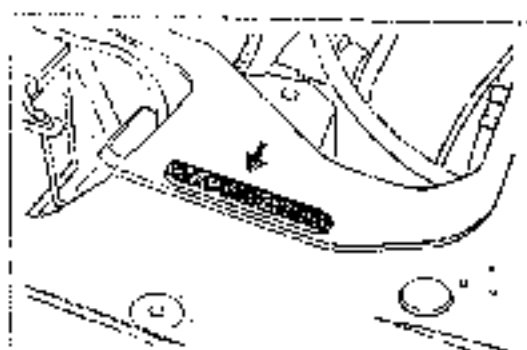

A75500010

## UNITS

N·m (kg·m, or kg·cm, lb-ft or lb-in)	Torque
rpm	Revolutions per minute
A	Ampere(s)
V	Volt(s)
$\Omega$	Ohm(s) (resistance)
kPa (kg/cm <sup>2</sup> , psi)	Pressure (usually negative)
mmHg (inHg)	Pressure (usually negative)
W	Watt
liters (US qt, imp qt)	Volume
mm (in)	Length

## ABBREVIATIONS

ABDC	After bottom dead center
A/C	Air conditioner
ACC	Accessories
A/T	Automatic transaxle
ATDC	After top dead center
ATF	Automatic transaxle fluid
BAC	Bypass air control
BBDC	Before bottom dead center
BTDC	Before top dead center
CPU	Central processing unit
DRL	Daytime running lights
EC-AT	Electronically-controlled automatic transaxle

PCM	Powertrain control module
MFI	Multiport fuel injection
EA	Electrical pad
EX	Exhaust
GND	Ground
HLA	Hydraulic lash adjuster
IGN	Ignition
IN	Intake
INT	Intermittent
IAC	Idle air control
LH	Left hand
M	Motor
MIL	Malfunction indicator lamp
MS	Manual steering
MT	Manual transaxle
OD	Overdrive
OFF	Switch off
ON	Switch on
PCV	Positive crankcase ventilation
PS	Power steering
PRC	Pressure regulator control
PW	Power window
RH	Right hand
SSI	Special service tool
ST	Start
SW	Switch
TDC	Top dead center
TNS	Tail number small lamp

## J2 ENGINE

10A

COMPRESSION PRESSURE .....	10A-10
DISASSEMBLY / ASSEMBLY .....	10A-17
ENGINE TUNE-UP PROCEDURE .....	10A- 5
IDLE SPEED .....	10A- 8
IDLE JP SPEED(A/T ONLY) .....	10A- 8
INJECTION TIMING .....	10A- 8
INSPECTION AND REPAIR .....	10A-30
REMOVAL / INSTALLATION .....	10A-11
SPECIAL TOOLS .....	10A-33
SPECIFICATION .....	10A-32
TROUBLESHOOTING GUIDE .....	10A- 3

## TROUBLESHOOTING GUIDE

Problem	Possible Cause	Action
Insufficient power	Improper valve clearance Valve seat compression leakage Valve stem seized Valve spring weak or broken Cylinder head gasket damaged Cylinder head cracked or distorted Piston ring sticking worn damaged Piston cracked or worn	Adjustment Repair Replace Replace Replace Replace Replace Replace
	Fuel system malfunctioning Intake and exhaust system malfunctioning	Refer to Section 22A Refer to Section 20A
Excessive engine oil consumption	Piston ring or piston ring groove worn or sticking Piston or cylinder worn Valve seal worn Valve stem end guide worn	Replace Replace or repair Replace Replace
	Oil leakage	Refer to Section 11A
Difficult to start	Worn piston, piston ring and cylinder Cylinder head damaged or distorted	Replace Replace
	Fuel system malfunctioning Electric system malfunctioning	Refer to Section 22A Refer to Section 20A
Abnormal combustion	Wrong adjustment of valve clearance Valve damaged or sticking Valve spring weak or broken Carbon deposit in combustion chamber Injection nozzle malfunctioning	Adjustment Replace Replace Removal Replace
	Fuel system malfunctioning	Refer to Section 22A
Poor idling	Improper valve clearance Improper valve to valve seat contact Cylinder head gasket damaged	Adjustment Repair or Replace Replace
	Fuel system malfunctioning	Refer to Section 22A
Engine noise	Excessive oil clearance of main bearing Main bearing seized or heat damage Excessive end play of crankshaft Excessive oil clearance of connecting rod bearing Connecting rod bearing seized or heat damage Connecting rod bush worn or seized	Replace or Repair Replace Replace or Repair Replace or Repair Replace Replace

10A-4 ENGINE TROUBLESHOOTING GUIDE

Problem	Possible Cause	Action
Engine noise	Worn cylinder Worn piston or piston pin Piston sticking Piston ring sticking or damaged Bent or connecting rod	Replace Replace Replace Replace Replace
	Excessive valve clearance Valve spring cracked Excessive valve guide clearance	Adjustment Replace Retrace
	Water pump bearing malfunction Improper fan belt tension Alternator bearing malfunction Cooling fan bearing malfunction Exhaust gas leakage Gas leakage at nozzle holder Assembly	Replace Adjustment Replace Replace Repair Repair

## ENGINE TUNE-UP PROCEDURE

### ENGINE OIL

#### Inspection

1. Be sure that vehicle is on level ground.
2. Warm up the engine to normal operating temperature and stop it.
3. Wait for 5 minutes, and then check oil level and its condition by using the oil level gauge.
4. Fill or replace oil if necessary.

#### Caution

- Excessive filling oil over F level can cause engine failure.

#### Note

- Oil quantity is about 1.8 l (1.9US qt, 1.6Imp qt) between F and L level of oil level gauge.

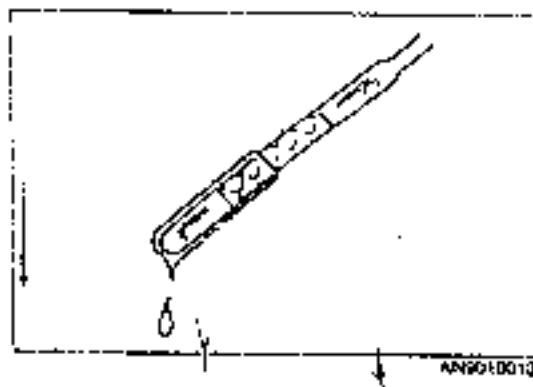

### ENGINE COOLANT

#### Warning

- Do not open the radiator cap when engine is hot.
- When opening the radiator cap, wrap it with thick cloth and open it with caution.

#### Inspection

1. Verify if the coolant level is near the radiator filling cap.
2. Check if the level of reservoir tank is between F and L marked level, and fill coolant if necessary.

#### Inspection of contamination

Check if any foreign material is in engine coolant and engine oil, replace it if necessary.

### DRIVE BELT

#### Inspection

1. Verify that the belt is correctly mounted on the pulleys as shown in the figure.
2. Check if the belt is worn, cracked or damaged, replace it if necessary.
3. Check the drive belt deflection by applying moderate pressure 10kg(98N, 22 lb) midway between the pulleys.

#### Caution

- Measure the belt deflection between the specified pulleys.
- Consider the belt as a new one if it has been used on a running engine for less than five minutes.
- Check the belt deflection when the engine is cold or at least 30 minutes after the engine is stopped.

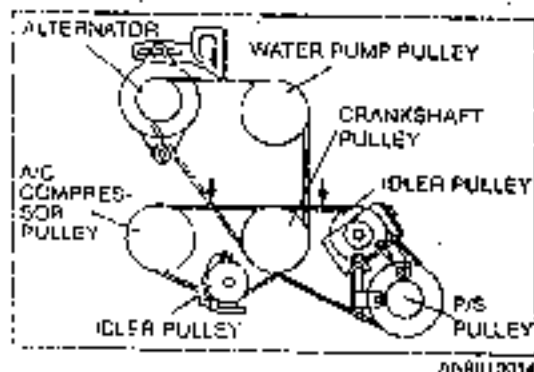

Belt	mm(in)	
	New	Used
Alternator	9~11(0.35~0.43)	11~12(0.43~0.47)
P/C	9~11(0.35~0.43)	11~12(0.43~0.47)
A/C	7~9(0.27~0.35)	9~10(0.35~0.43)

- If the deflection is not correct, adjust the belt.

**Note**

- For inspecting the tension by the tension gauge

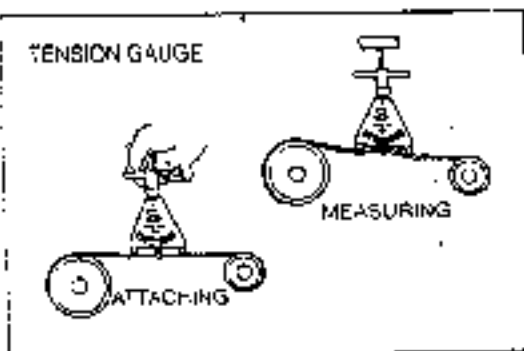

AN9010015

Belt	N(kg, lb)	
	New	Used
Alternator	441~539(45~55, 99~121)	382~441(39~45, 86~99)
P/C	383~441(37~45, 81~99)	323~362(33~37, 73~81)
A/C	421~827(43~84, 95~141)	304~421(31~43, 68~95)

**Alternator drive belt**

- Loosen the mounting bolt (A) for alternator and the adjusting bolt (B).
- Adjust the belt deflection.  
**Deflection (When applying 98 N(10 kg, 22 lb))**  
 New one : 9~11 mm(0.35~0.43 in)  
 Used one : 11~12 mm(0.43~0.47 in)
- After making the adjustment, tighten the mounting bolt (A) and adjusting bolt (B).

**Tightening torque**

- (A) 37~52 N·m(3.8~5.3 kg·m, 28~38 lb)
- (B) 19~25 N·m(1.9~2.6 kg·m, 14~19 lb)

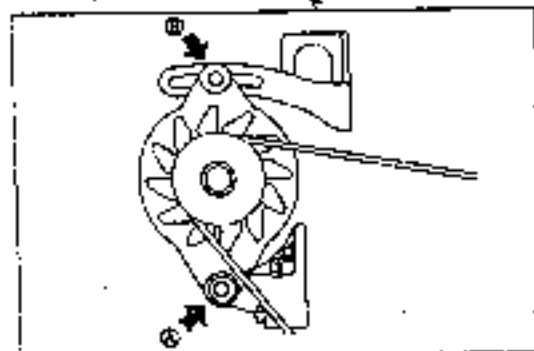

AN9010016

**Power steering drive belt**

- Loosen the idler pulley mounting bolt (A).
- Adjust the belt deflection by turning the adjusting bolt (B).

**Deflection (When applying 98 N(10kg, 22 lb))**  
 New one : 9~11 mm(0.35~0.43 in)  
 Used one : 11~12 mm(0.43~0.47 in)

- After making the adjustment, tighten the idler pulley mounting bolt.

**Tightening torque**

37~52 N·m(3.8~5.3 kg·m, 28~38 lb)

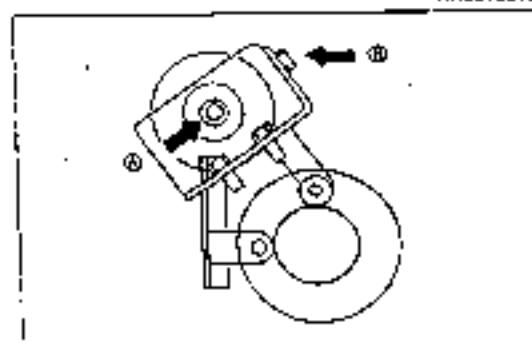

AN9010017

**Air conditioner drive belt**

Do it with the same way as measured for P/S belt tension, referring figure.

Adjust the belt deflection with the same way as described for "Power steering drive belt".

**Deflection**

New one : 7~9 mm(0.27~0.35 in)  
 Used one : 9~11 mm(0.35~0.43 in)

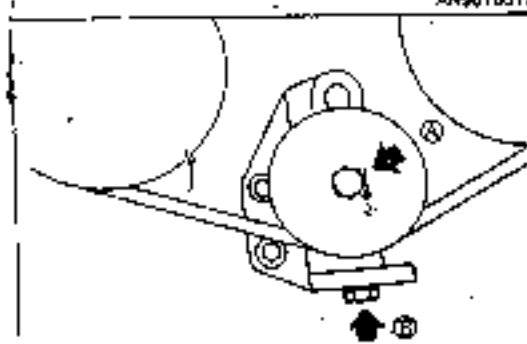

AN9010018

**VALVE CLEARANCE****Inspection / Adjustment**

1. Remove the cylinder head cover.
2. Set the No. 1 piston to TDC by rotating the crankshaft.

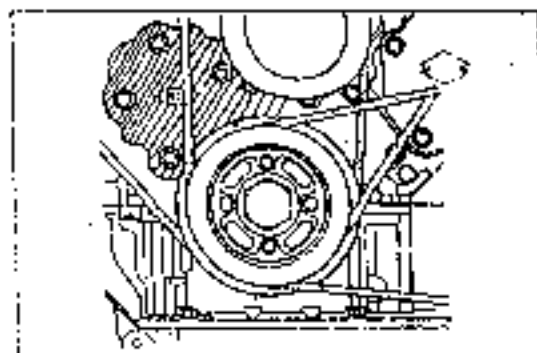

AN9010032

3. Check and adjust the valve clearance.

**Valve clearance (at cold) :**

Intake (No. 1, No. 2) : 0.30 mm(0.012 in)

Exhaust (No. 1, No. 3) : 0.38 mm(0.015 in)

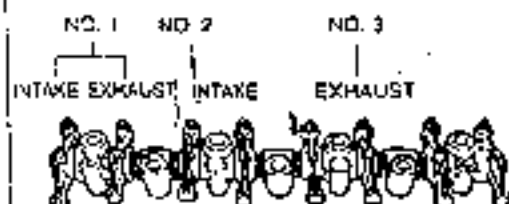

--- ENGINE FRONT

AN9010032

4. Loosen the tightening nut, rotate the adjusting screw and adjust the valve clearance.

Tightening torque : 12-18 N·m(1.2-1.8 kg·m, 8.7-13 lb)



AN9010032

5. Turn the crankshaft 1 revolution and check another valve.

Intake : No. 3, No. 4

Exhaust : No. 2, No. 4



--- ENGINE FRONT

AN9010032



## IDLE SPEED

### INJECTION TIMING, CAM LIFT

#### Preparation

1. Warm up the engine up to the normal operating temperature.
2. Operate the engine at idle.
  - ① Put the change lever in neutral position.
  - ② Put the steering in neutral.
  - ③ Turn the ignition switch OFF.
3. Check if the deflection of accelerator cable is within the specification (refer to Section 20).

Specification : 1~3 mm(0.04~0.12 in)

#### Inspection / Adjustment

1. measure the engine idle speed by using a tachometer.

Specification : 700~750 rpm(A/T)  
750~790 rpm(M/T)

2. If it exceeds the specification, loosen the tightening nut and adjust it by rotating the idle adjust screw.

Tightening torque : 5.0~8.8 N·m(0.5~0.9 kg·m, 3.7~6.5 lb·ft)

#### Caution

- The idle speed adjustment should be done by the idle adjusting screw.

## IDLE UP SPEED(A/T ONLY)

### ON-VEHICLE MAINTENANCE

1. Check and adjust the idle speed.
2. Start the engine and turn the air conditioner switch ON
3. Check that the idle speed is within the specified range.

Specification : 850~900 rpm

4. If it exceeds the specification, loosen the No. 1 idle diaphragm tightening nut and adjust it by rotating the idle adjusting screw.

Tightening torque :  
1.18~1.47 N·m(0.12~0.15 kg·m, 0.07~1.09 lb·ft)

5. If adjustment can not be done, loosen the bolt and readjust it by using the actuator body.

Tightening torque : 8~11 N·m(0.8~1.1 kg·m, 6~8 lb·ft)

6. Connect the vacuum hose and operate A/C, then turn the blower switch on and verify the engine speed.

Specification ; 850~900 rpm

## INJECTION TIMING

### INSPECTION / ADJUSTMENT

1. Rotate the crankshaft slowly and align it ATDC 7°.

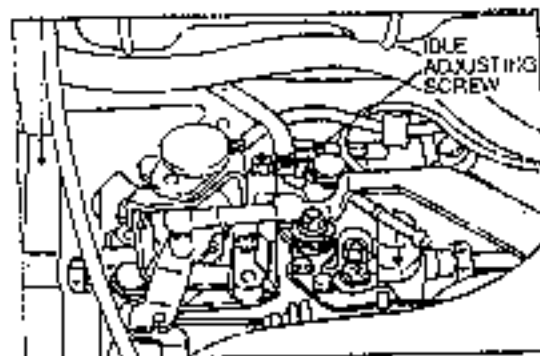

AN9010C01

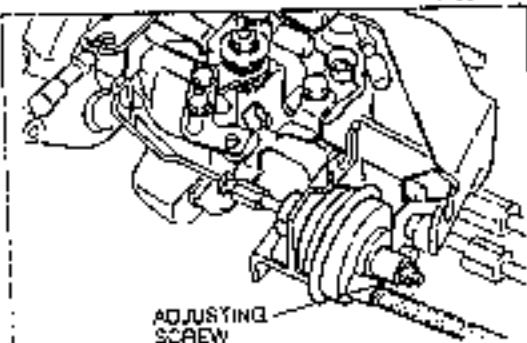

AN9010A-03

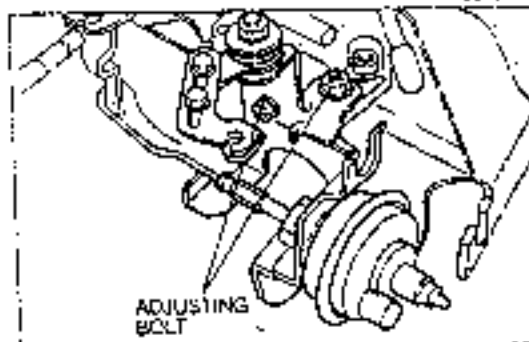

AN9010D-04

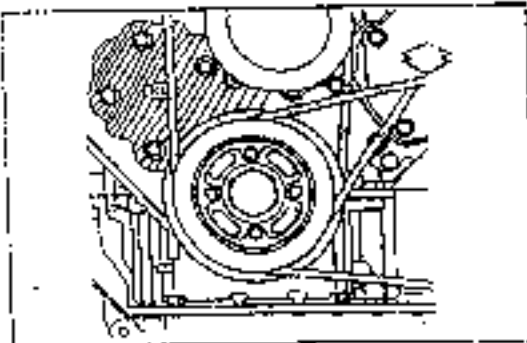

AN9010E-02

- Remove the injection pipe between the injection pump and the nozzle.
- After removing the cover of hydraulic part of injection pump, install SST.

**Caution**

- Be careful for fuel leak during removing the injection pump.
- Install it so that SST indicates about 2 mm(0.079 in).

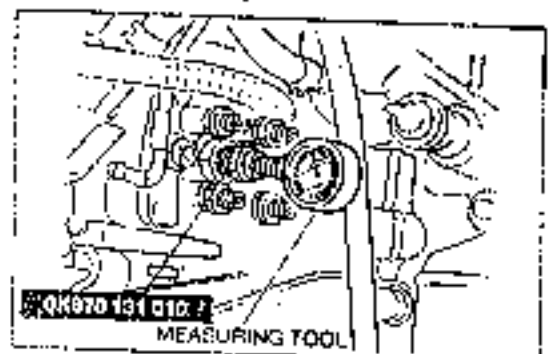

- Rotate the crankshaft pulley in reverse to align it to BTDC 30°, then install the dial gauge so that its indicator can not be moved.
- Align the indicator of dial gauge to 0, rotate the crankshaft pulley in left and right, and then verify the position of indicator.
- Rotate the crankshaft pulley again to align it to ATDC 7°, and then check the dial gauge reading.

Specification :  $1 \pm 0.02$  mm (Lift)

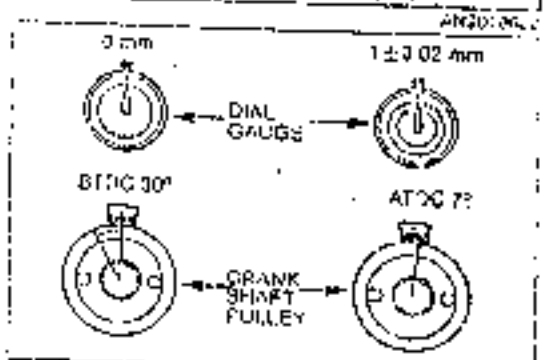

- If the dial gauge reading exceeds the specification, loosen the stay bolt of injection pump.
- Loosen the tightening nut (C) for the injection pump by using a socket wrench.
- Rotate the injection pump body so that the dial gauge indicates 0.98-1.02 mm (0.039-0.040 in) at ATDC 7°.
- Tighten the stay bolt of injection pump and the tightening bolt.

Tightening torque : 19-25 N·m(1.9-2.6 kg-m, 14-19 lb-ft)

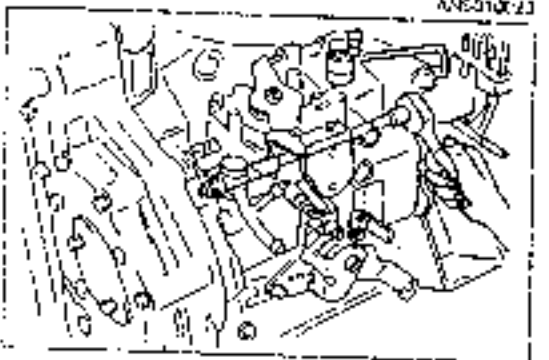

- Remove SST.
- Insert a cap after inserting a new gasket.

Tightening torque : 14-20 N·m(1.4-2.0 kg-m, 10-15 lb-ft)

- Tighten the injection pipe temporarily and tighten nuts (4 EA) on pump side.

Tightening torque : 25-29 N·m(2.5-3.0 kg-m, 18-22 lb-ft)

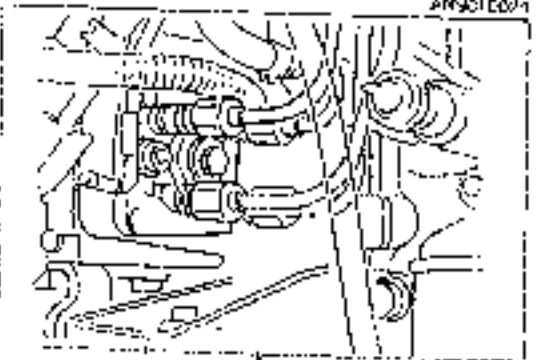

- After starting engine, check if there is any fuel leakage.

**INSPECTION OF CAM LIFT**

- Check the maximum dial gauge reading during inspecting and adjusting injection timing.
- Rotate the pulley so that it passes TDC, then check the maximum dial gauge reading.

Cam Lift : 2.6 mm(0.1 in)

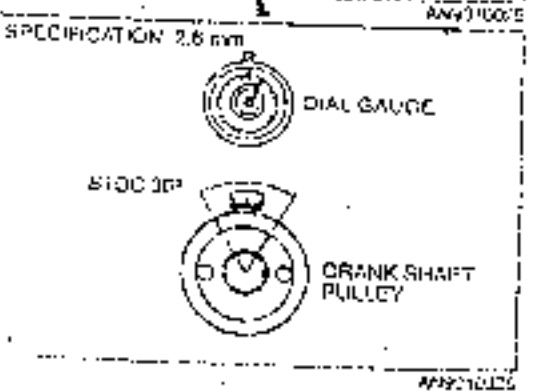

## 10A-10 ENGINE COMPRESSION PRESSURE

### COMPRESSION PRESSURE

#### INSPECTION

1. Warm up engine upto the normal operating temperature, stop engine and disconnect the connector of fuel cut solenoid.
2. Remove all injection pipes, nozzles and washers.
3. Attach SST to the nozzle hole.
4. Measure the compression pressure during cranking.

		Specification
Compression pressure (kg/cm <sup>2</sup> -psm)	Normal	30.0-200
	Limit	27.0-200
Cylinder-to-cylinder pressure difference		below 3.0

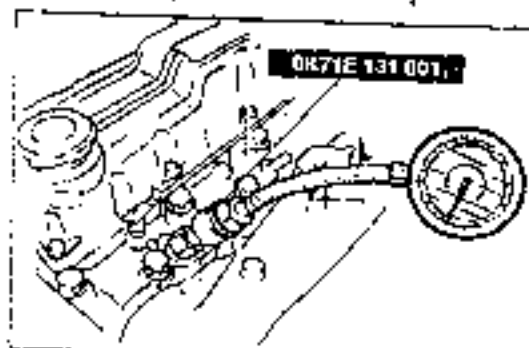

AM90-0027

5. Do above step 3 - step 4 again for each cylinder.
6. If the measure value is below the limit, consider it as abrasion or damage of piston and piston ring, misalignment of valve, damage of gasket etc..

## REMOVAL / INSTALLATION

1. Remove the negative cable of battery.
2. Drain the engine coolant and transmission oil.
3. Remove in steps as shown in figure, and install in reverse order of removal.
4. After installing, fill the engine coolant, engine oil and transmission oil as specified.
5. After driving tests, check for water or oil leakage, and inspect the coolant level and engine oil level again.

## STEP 1. (SEAT AND PARKING BRAKE FRAME)

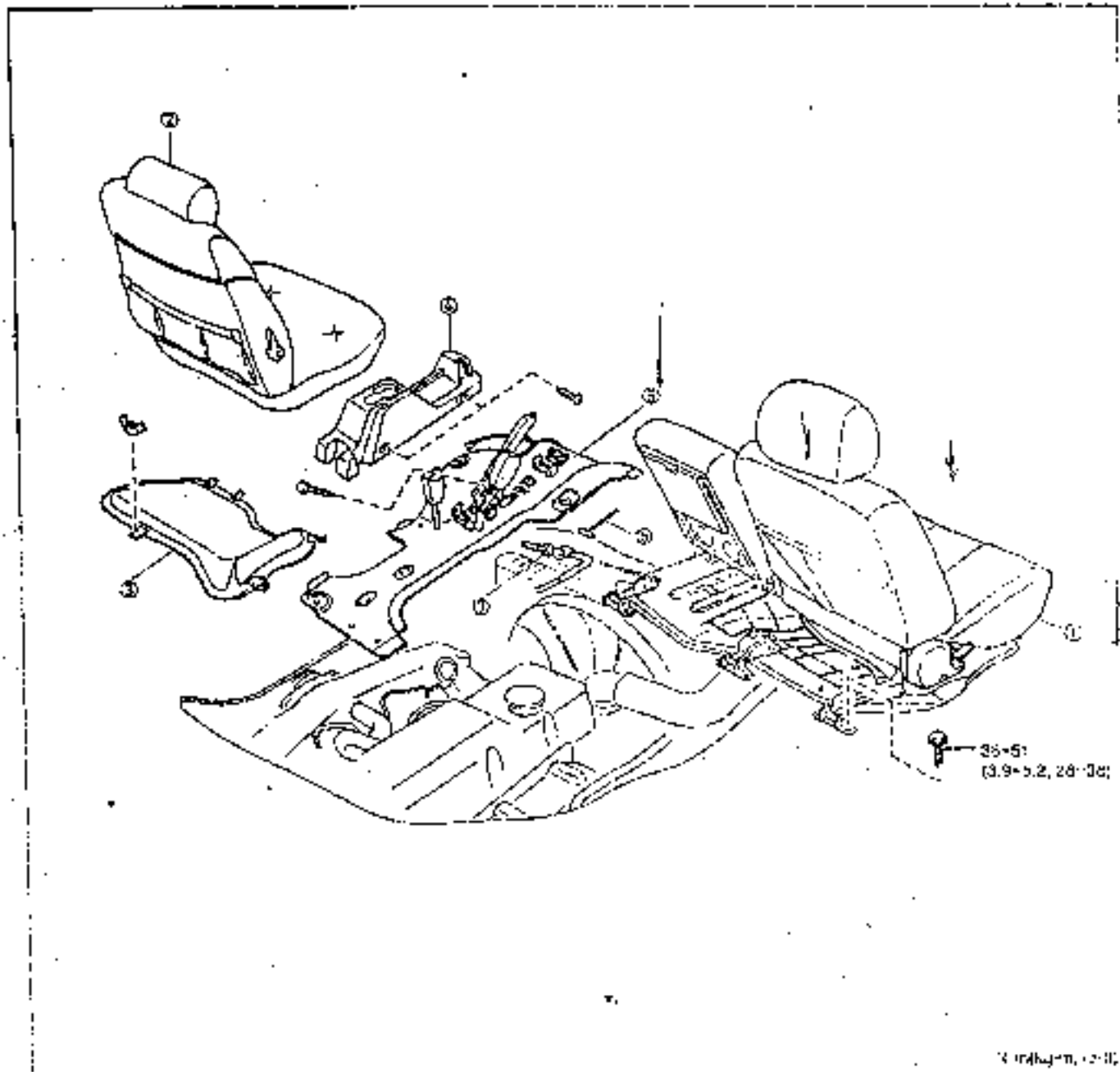

1. Passenger seat
2. Driver seat
3. Service cover
4. Console box

5. Parking brake frame
6. Fuel tank opener cable
7. Parking brake cable

STEP 2. (HOSES AND ACCELERATOR CABLE)

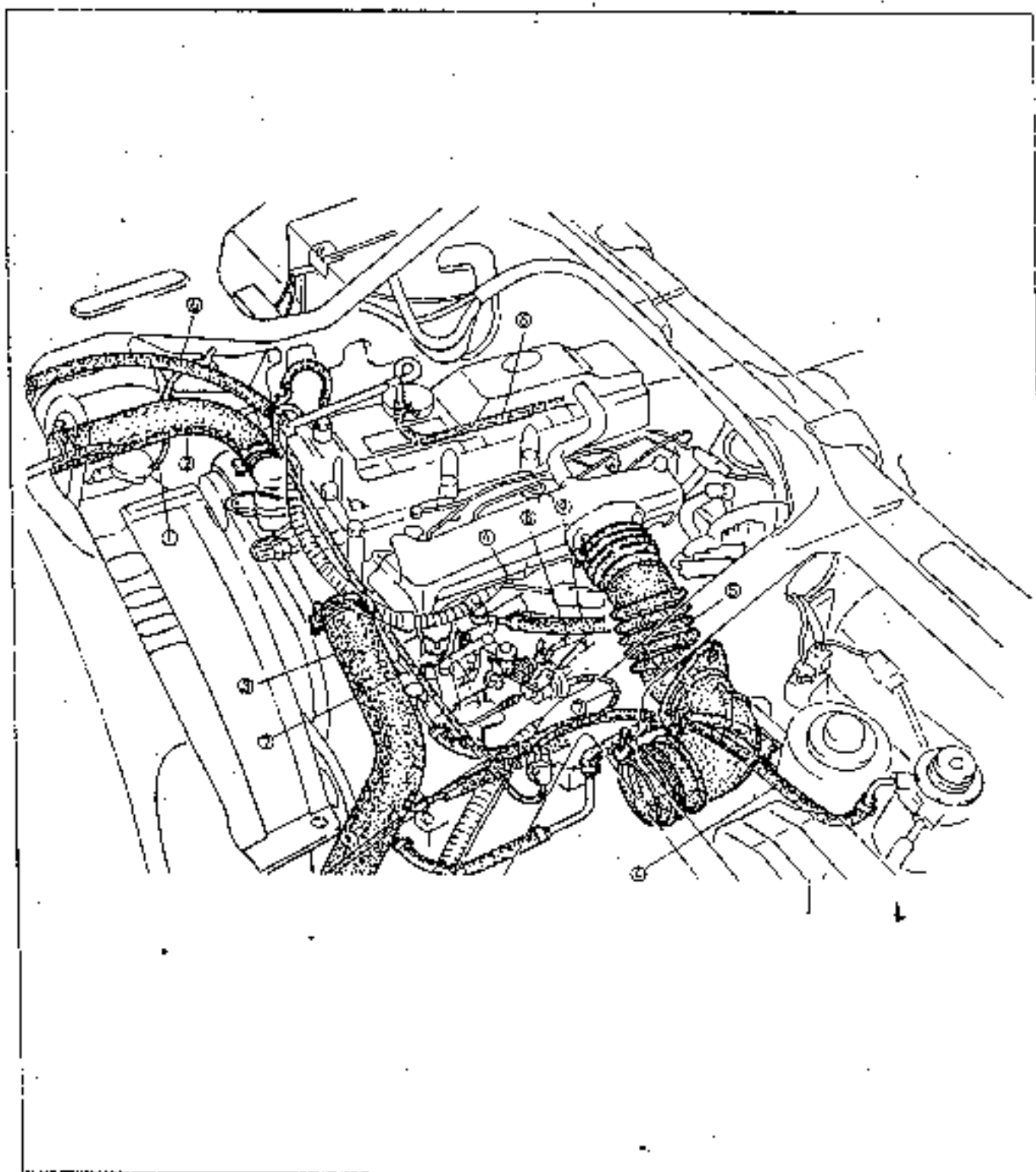

Ar9210055

- 1. Reserve tank hose
- 2. Radiator upper hose
- 3. Radiator lower hose
- 4. Fuel hose
- 5. Air hose

- 6. Heater hose
- 7. Solenoid hose
- 8. Accelerator cable
- 9. Throttle cable (ATX only)

## STEP 3. (WIRING HARNESS)

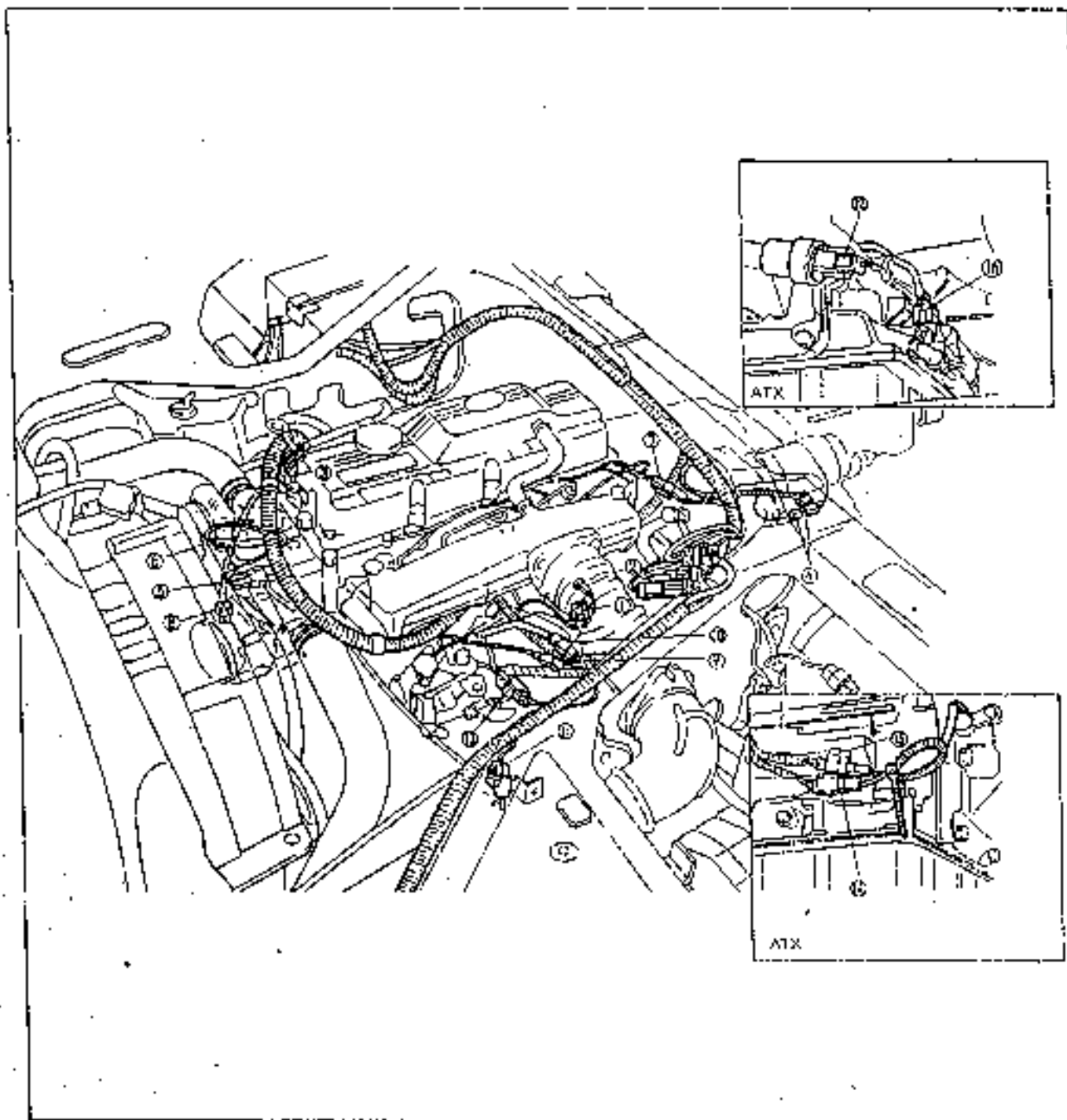

1. Oil pressure switch
2. Water thermo switch (ATX only)
3. Alternator connector
4. Starter
5. Thermo switch
6. Heat gage unit
7. Glow plug connector
8. Air con compressor connector

9. Fuel cut solenoid connector
10. Pickup connector
11. FICD solenoid connector
12. Speedsensor connector
13. TPS connector (ATX only)
14. Speed sensor connector (ATX only)
15. Solenoid sensor connector (ATX only)
16. Initiator switch connector (ATX only)

# 10A-14 ENGINE REMOVAL / INSTALLATION

## STEP 3.

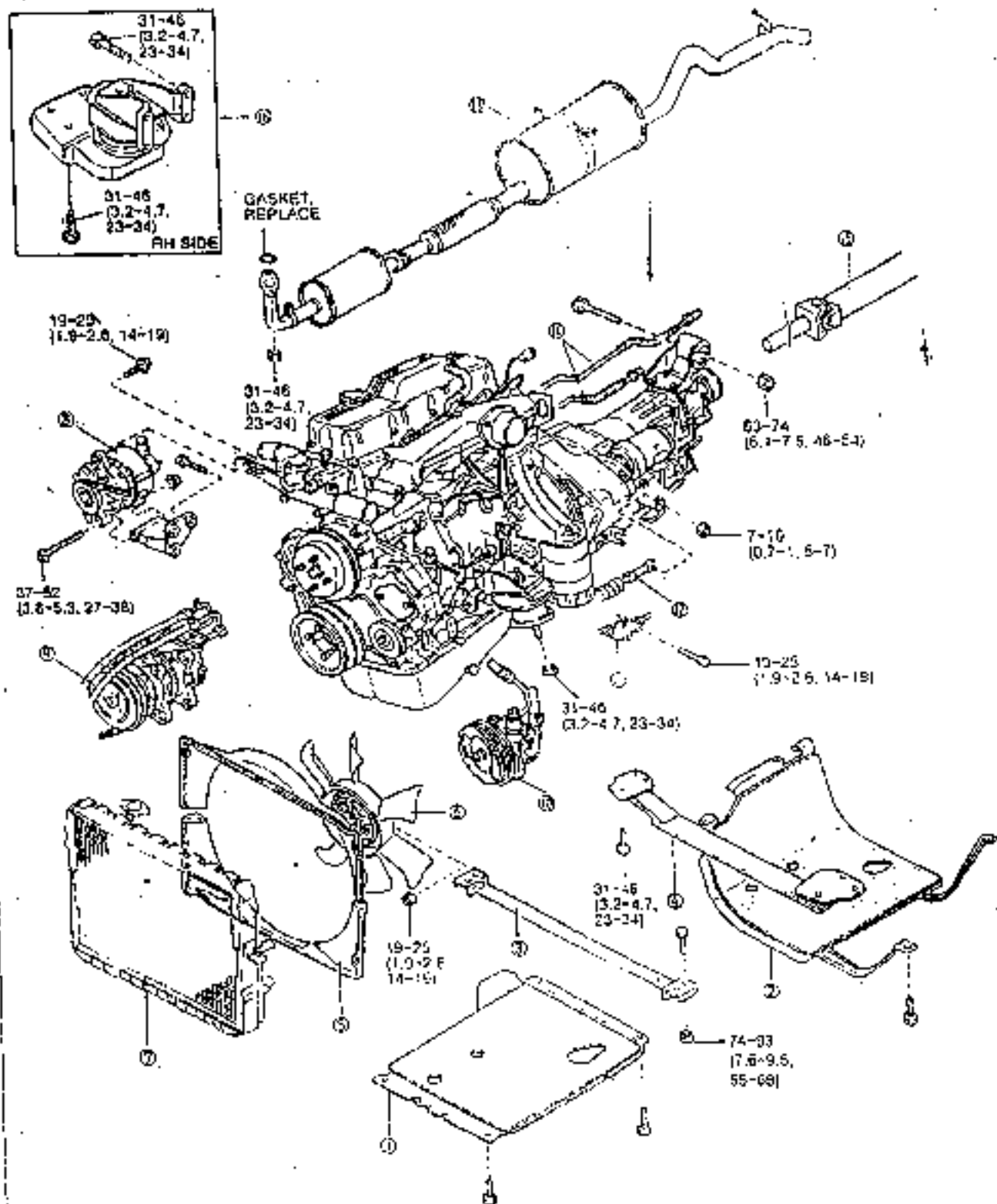

N·m (kg·m, ft·lb)

ANGL' 0057

1. Engine under cover
2. Transmission under cover
3. Cross pipe
4. Cross member
5. Thermo modulator fan cover
6. Thermo modulator fan
7. Radiator
8. Alternator
9. Air con compressor
10. Power steering oil pump
11. Clutch release cylinder (MTX only)
12. Selector lever cable (ATX only)
13. Exhaust pipe
14. ATF pipe (ATX only)
15. Propeller shaft
16. Engine mount assembly

**REMOVAL NOTE**

**Power steering oil pump**

1. Remove the power steering oil pump with bracket from engine body.
2. Remove the power steering oil pump with oil hose attached, and fix it by wire somewhere the engine removal can not be interfered.

**Caution**

- Be careful not to damage the hose.

**Air con compressor**

1. Remove the air con compressor with bracket from engine body.
2. Remove the air con compressor with hose attached, and fix it by wire somewhere the engine removal can not be interfered.

**Caution**

- Be careful not to damage the hose.

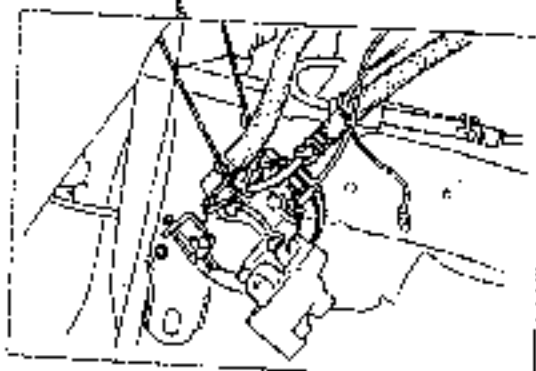

95X0194069

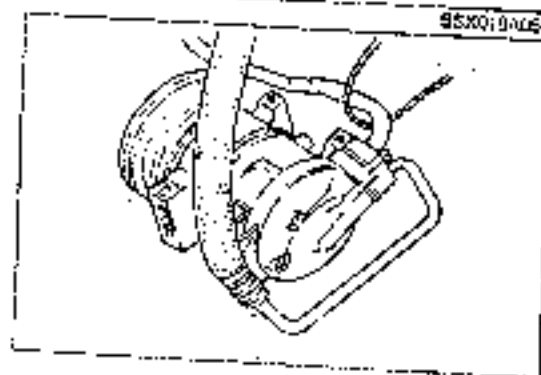

05Y076A000



# 10A-16 ENGINE REMOVAL/INSTALLATION

## STEP 4. (ENGINE AND TRANSMISSION)

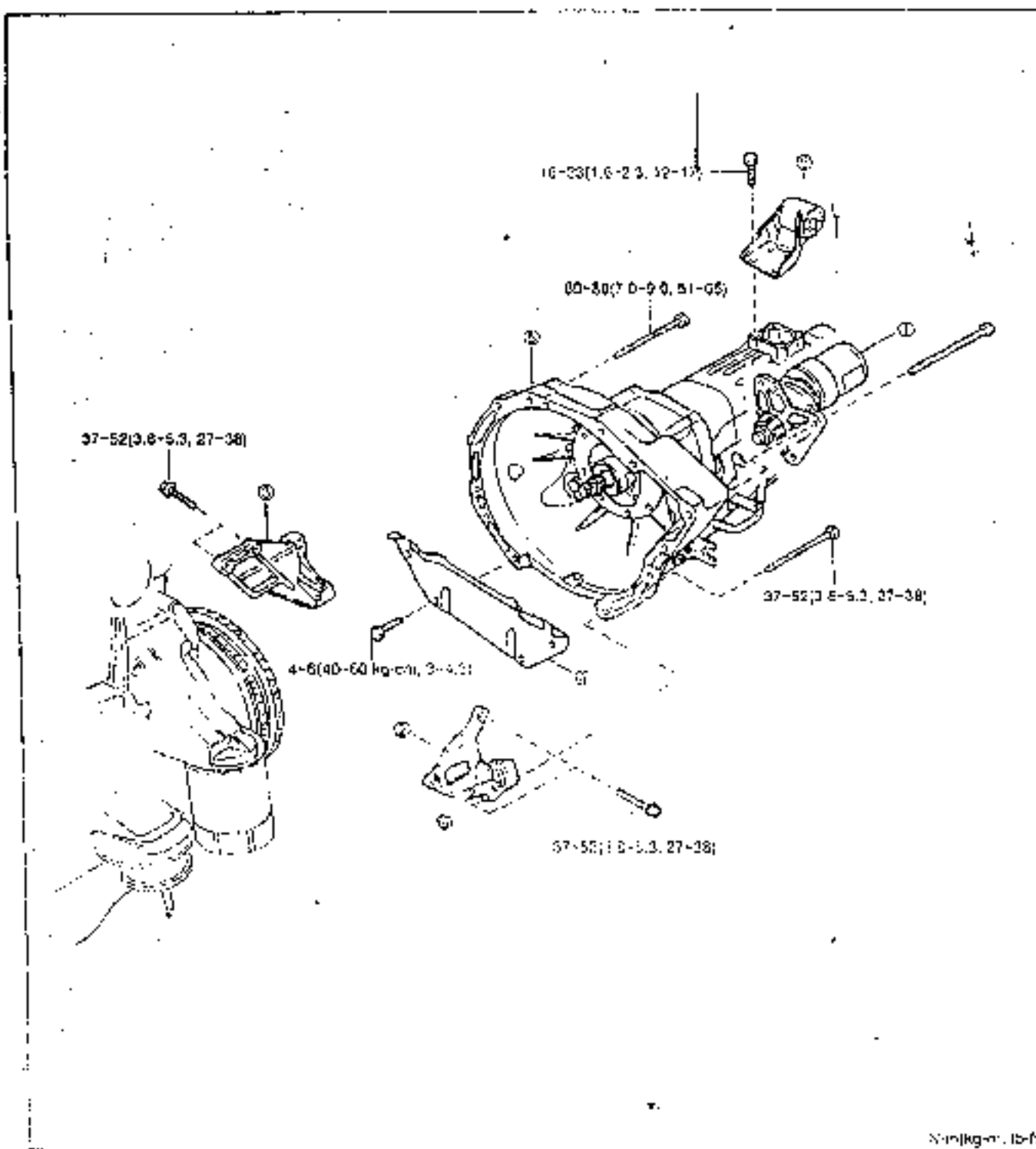

Springer, Inc.  
1992-0050

- 1. Starter motor
- 2. Gusset plate(LH)
- 3. Gusset plate(RH)

- 4. Under cover
- 5. Transmission mounting
- 6. Auto transmission

## DISASSEMBLY / ASSEMBLY

1. Drain the engine oil.
2. Remove in the sequence shown in the figure below, and install in the reverse order of removal.
3. Refer to each notes for disassembly and assembly.

## Caution

- Mark all parts removed from cylinder so that those can be properly installed later. (Piston, piston ring, connecting rod, valve spring etc.)
- Wash parts thoroughly with steam cleaner, blow out any water left with compressed air.
- Keep the assembly order in mind during disassembly of any part or system. Careful also for any deformation, wear or damage.

## OTHERS

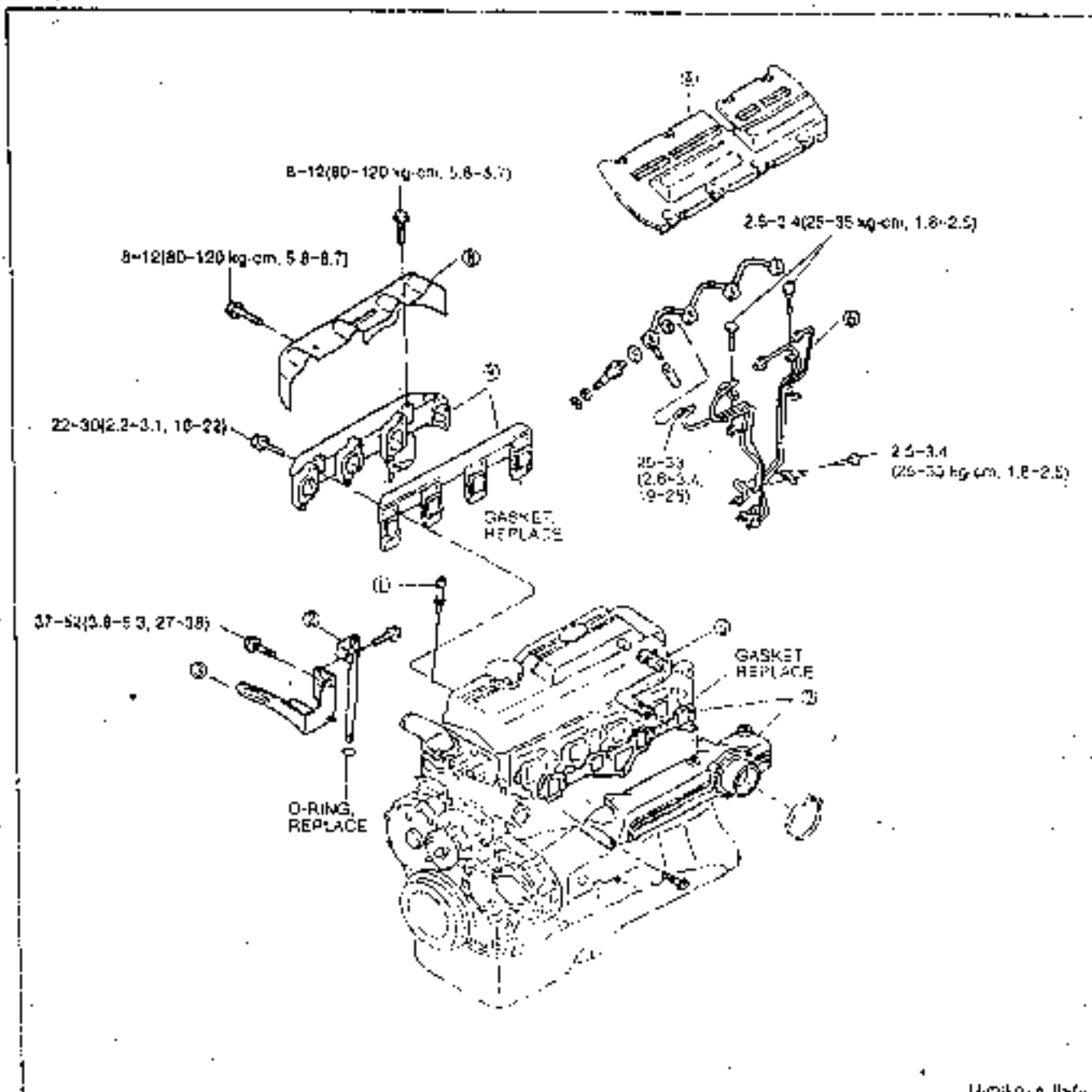

## 10A-18 ENGINE DISASSEMBLY / ASSEMBLY

1. Oil level gauge
2. Oil level gauge Pipe
3. Alternator strap
4. Nozzle cover
5. PCV hose
6. Injection pipe
7. Intake manifold and gasket
8. Exhaust manifold insulator
9. Exhaust manifold and gasket

### Disassembly note

1. Install **SST** to engine after removing the exhaust manifold and alternator.

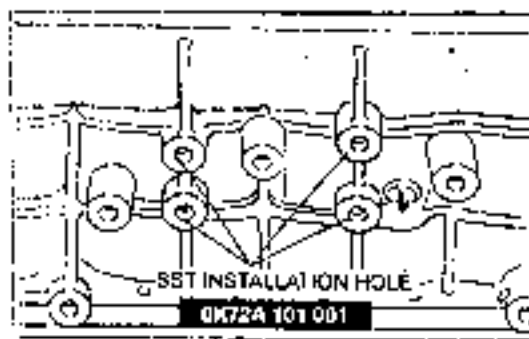

AN8010012

### Assembly note

1. Install the oil hose after installing alternator.

Tightening torque : 688-882 N·m(60-90 kg-m, 435-653 lb-ft)

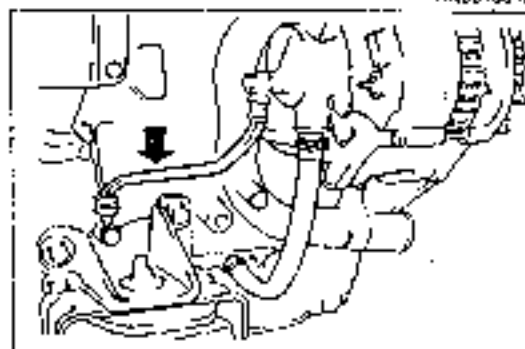

AN8040020

## CYLINDER HEAD

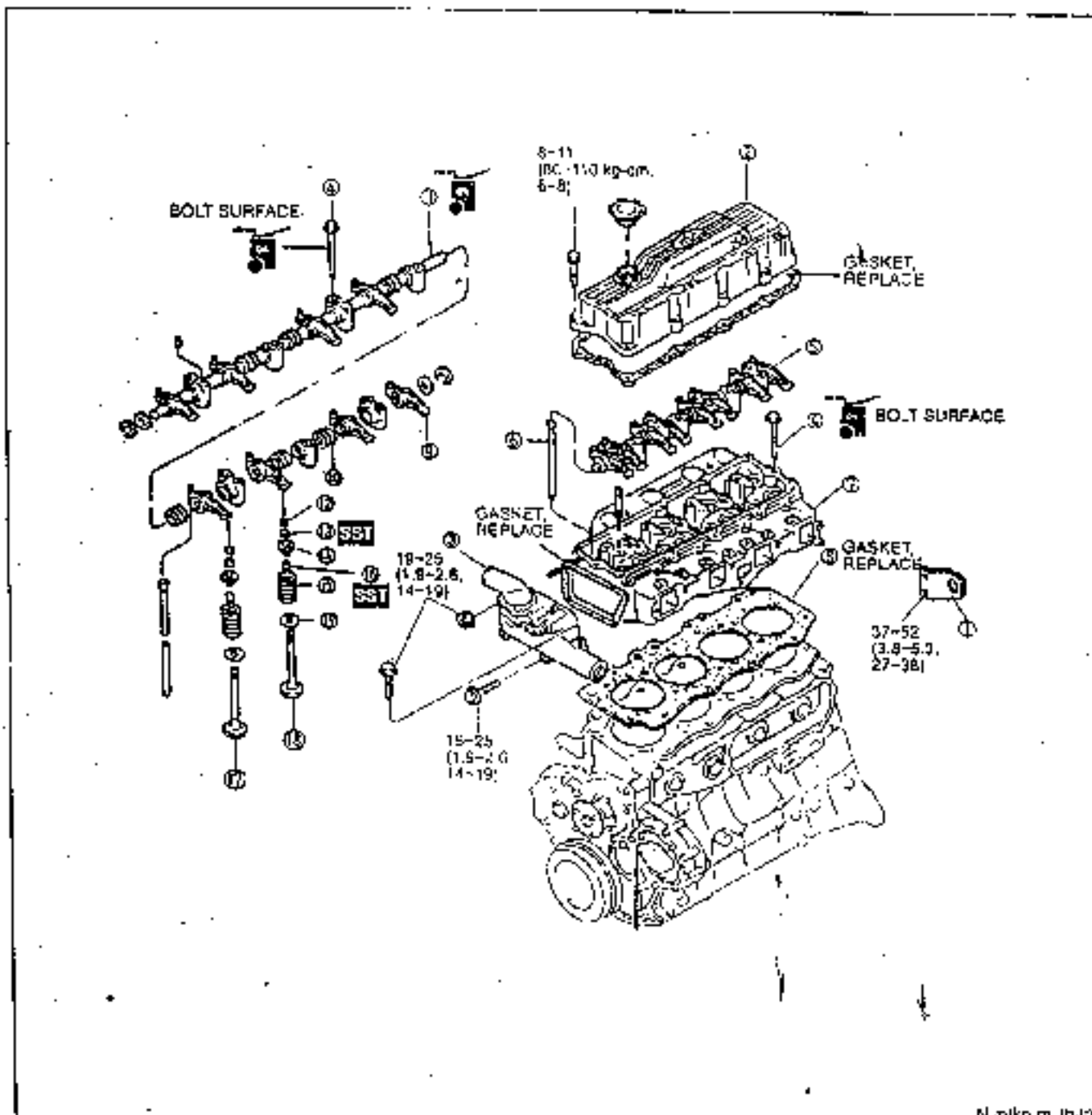

N.m/kg m, lb-ft

ANSI 10A-19

- |   |                             |
|---|-----------------------------|
| 1. Engine hanger                            | 11. Rocker arm shaft        |
| 2. Cylinder head cover                      | 12. Valve cap               |
| 3. Thermo case and gasket                   | 13. Valve cotter            |
| 4. Cylinder head bolt                       | 14. Upper valve spring seal |
| 5. Rocker arm and rocker arm shaft assembly | 15. Valve spring            |
| 6. Push rod                                 | 16. Valve seal              |
| 7. Cylinder head                            | 17. Intake valve            |
| 8. Cylinder head gasket                     | 18. Exhaust valve           |
| 9. Rocker arm                               | 19. Lower valve spring seat |
| 10. Rocker arm spring                       |                             |

# 10A-20 ENGINE DISASSEMBLY / ASSEMBLY

## DISASSEMBLY NOTE

### Cylinder Head Bolt

Loosen the cylinder head bolts in two or three steps in the numbered order as shown in the figure.

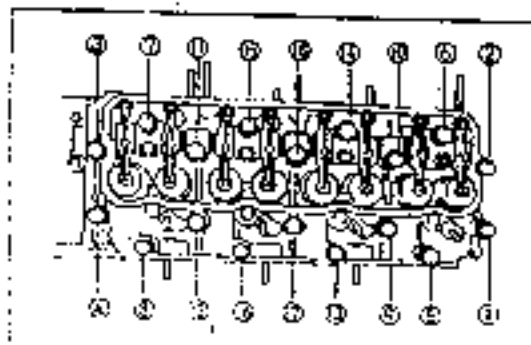

AN9010020

### Valve Cotter

Remove the valve cotter by using SST as shown in the figure.

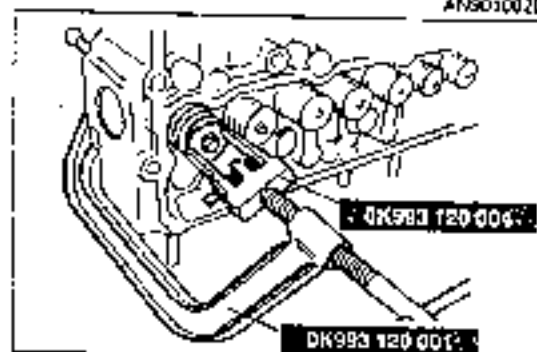

AN9010030

### Valve Seal

Pull the valve seal out by using SST.

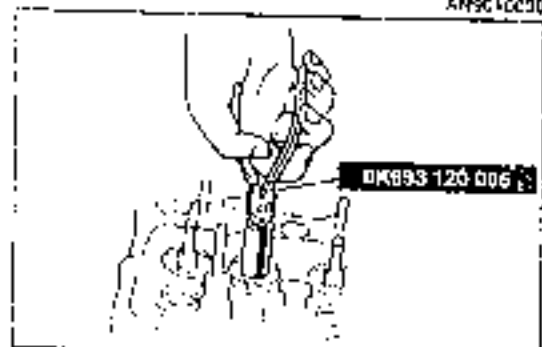

AN9010031

**ASSEMBLY NOTE****Valve Seal**

Push the valve seal by using SST as shown in the figure.

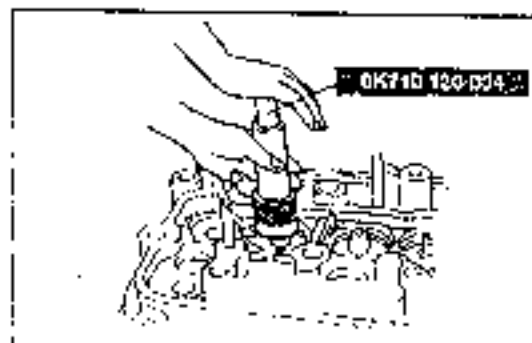

AN9313034

**Cylinder Head Bolt****Note**

- \* mark in the figure means short bolt, ○ mark means long bolt.

**Caution**

- Measure the length of cylinder head bolt, replace if necessary.

Long bolt : 158 mm(6.22 in)

Short bolt : 123 mm(4.84 in)

1. Apply engine oil onto the surface and thread of cylinder head bolt, and install to cylinder head.
2. Tighten cylinder head bolts with 44~74 N·m(4.5~7.5 kg-m, 33~54 lb-ft) of tightening torque, in the order shown in figure (1st temporary tightening).
3. Tighten it with rotating 90° (2nd tightening).
4. Tighten it with rotating 90° (3rd tightening).

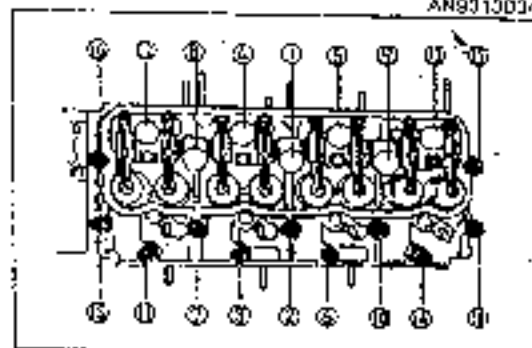

AN9216035

**Valve Cotter**

1. Compress the spring by using SST to install the valve cotter.
2. Check if the cotter is completely positioned, by tapping the end of valve stem slightly with a plastic hammer.

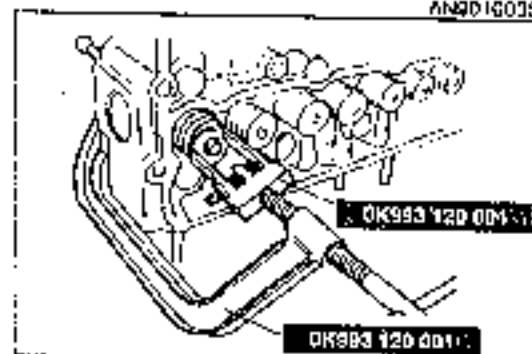

AN9310030

**Water Outlet Housing**

1. After tightening the thermo case to cylinder head temporarily by using "D" bolt and "S" nut, tighten "R" and "W" completely, then "D" and "S" completely.

**Tightening torque**

D, R, S, W : 19~25N·m(1.9~2.6 kg-m, 14~19 lb-ft)

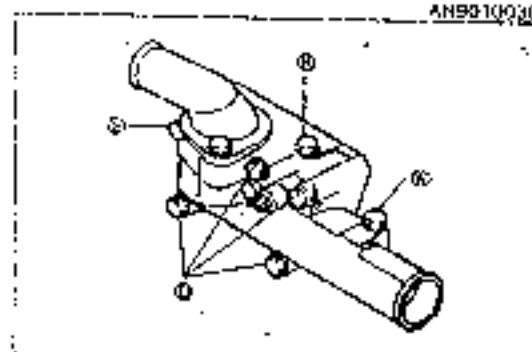

AN9310030

FLYWHEEL AND OIL PAN

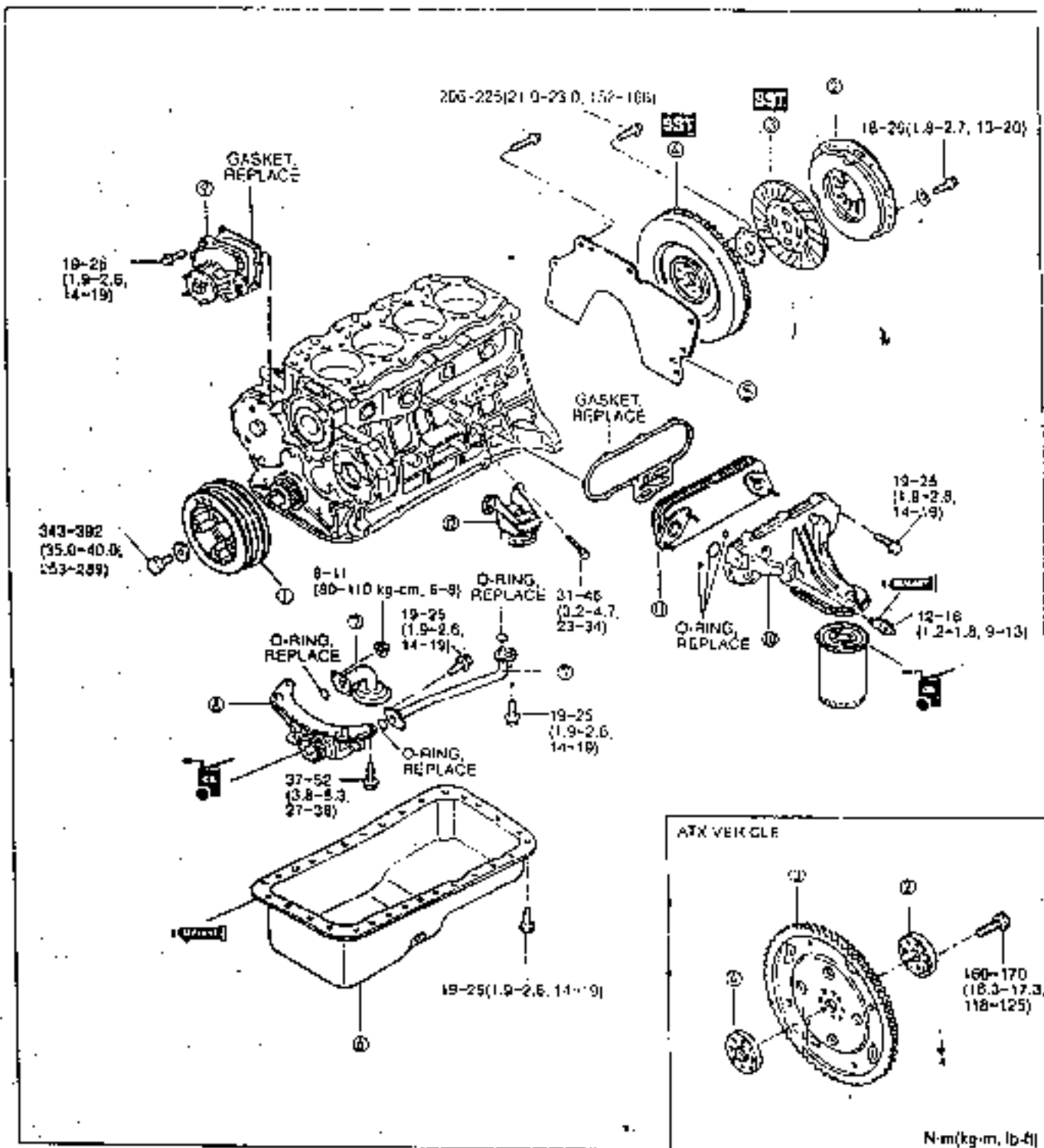

1. Crankshaft pulley
2. Clutch cover (MTX only), backing plate (ATX only)
3. Clutch disc (MTX only), drive plate (ATX only)
4. Flywheel (MTX only), adapter (ATX only)
5. End plate
6. Oil pan

7. Oil strainer and pipe
8. Oil Pump
9. Water pump and gasket
10. Oil filter body and gasket
11. Oil cooler
12. Engine mounting

**DISASSEMBLY NOTE****Crankshaft Pulley, Clutch Cover**

1. Hold the flywheel with the SST.
2. Remove the crankshaft pulley.
3. Remove the clutch cover by loosening the bolts in two or three steps.

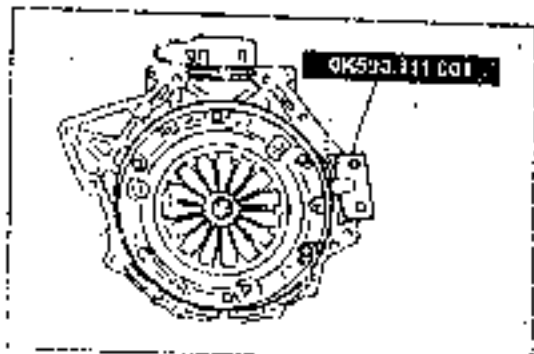

AN9110337

**Flywheel**

1. Install SST to the flywheel link gear so that it can not be rotated. Hold the flywheel with the SST.
2. Loosen the tightening bolt for flywheel in two or three steps.

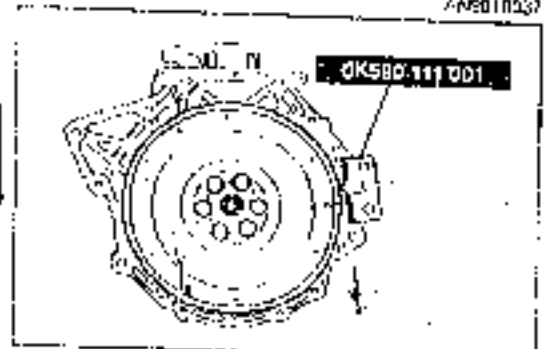

AN9110008

**ASSEMBLY NOTE****Clutch Disc, Clutch Cover**

1. Align the center of clutch disc by using SST.

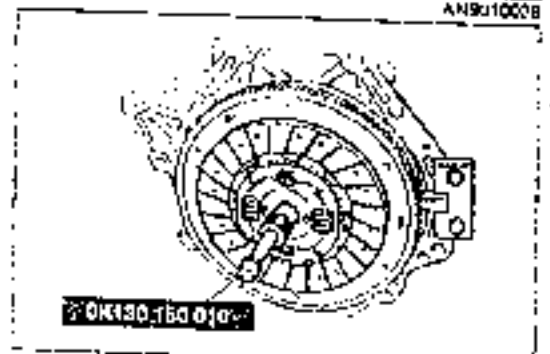

AN9110058





- |                              |                          |
|------------------------------|--------------------------|
| 1. Front oil seal            | 10. Idle gear            |
| 2. Injection pump gear cover | 11. Spindle              |
| 3. Seal plate                | 12. Fuel injection pump  |
| 4. Timing gear cover         | 13. Oil deflector        |
| 5. Friction gear             | 14. Friction gear spring |
| 6. Injection pump gear       | 15. Friction gear        |
| 7. Friction gear             | 16. Timing gear case     |
| 8. Camshaft gear             | 17. Rear oil seal        |
| 9. Thrust plate              |                          |

**DISASSEMBLY NOTE****Camshaft Gear**

1. Hold the camshaft gear with the SST.
2. Remove the lock nut of injection pump gear.

3. Remove the injection pump gear by using SST as shown in the figure.
4. Remove the camshaft gear and idling gear.

**ASSEMBLY NOTE****Timing Gear****Note**

- Install the timing gear so that its mark can be aligned to BTOC 30°.

1. Install all gears with aligning all matching marks of gear together as shown in the figure.

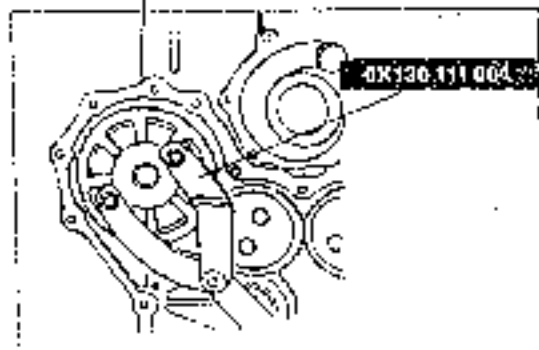

AN001004

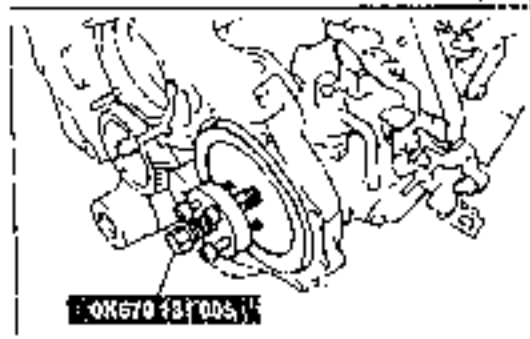

AN001005

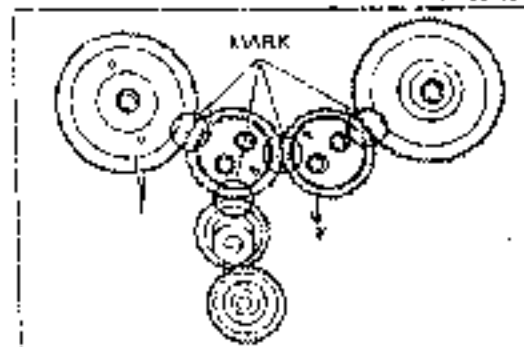

AN010810

# 10A-26 ENGINE DISASSEMBLY / ASSEMBLY

## CYLINDER BLOCK

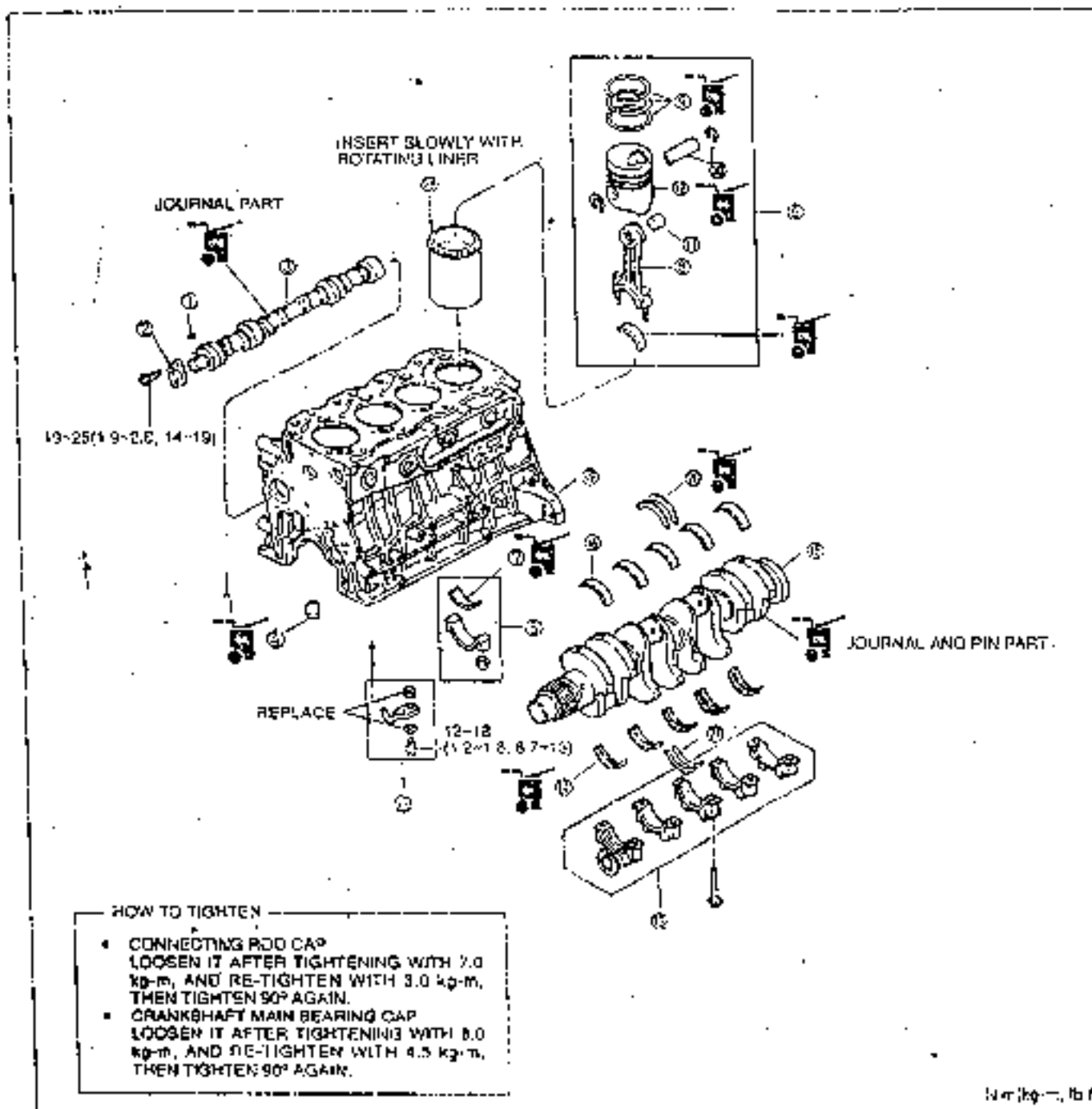

1. Woodruff key
2. Camshaft thrust plate
3. Camshaft
4. Tappet
5. Connecting rod cap
6. Connecting rod and piston assembly
7. Connecting rod bearing
8. Connecting rod
9. Piston ring
10. Snap ring and piston pin
11. Connecting rod bush

12. Piston
13. Main bearing cap
14. Lower main bearing
15. Crankshaft
16. Upper main bearing
17. Piston cooling jet
18. Cylinder liner
19. Cylinder block
20. Upper thrust metal
21. Lower thrust metal

21910011

**DISASSEMBLY NOTE****Connecting Rod and Cap**

1. Before removing the connecting rod, clean the bearing, connecting rod and crankpin, and check the following.
  - Connecting rod side clearance. (refer to page 10A-28)
  - Crank pin oil clearance. (refer to page 10A-28)

**Main Bearing Cap**

1. Before removing the main bearing cap, clean the bearing and main journal cap, and check the following.
  - Crankshaft end play. (refer to page 10A-27)
  - Main journal oil clearance. (refer to page 10A-27)

**ASSEMBLY NOTE****Piston Ring**

1. Assemble in the order of the oil ring expander, oil ring, second ring and top ring.

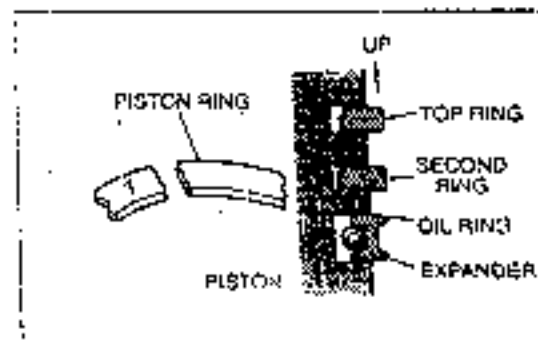

AN7010015

**Crankshaft Main Journal Bearing Oil Clearance and End Play**

1. Remove any foreign material or oil from the journal and bearing.
2. Install the upper main bearing to cylinder block.
3. Align the crankshaft to the cylinder block.
4. Install the plastic gauge onto the upper side of journal in axial direction.

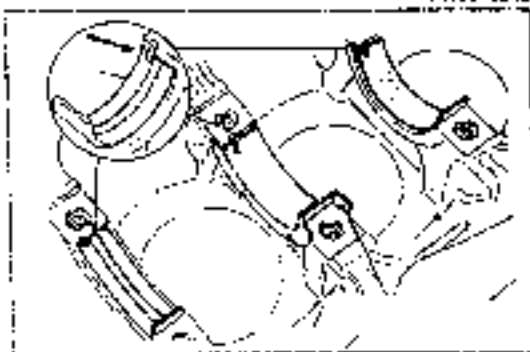

AN9310069

5. Loosen after tightening with 78 N·m(6.0 kg-m, 59 lb-ft) and re-tighten with 44 N·m(4.5 kg-m, 33 lb-ft) then tighten 90° again.

**Caution**

- Do not rotate the crankshaft when measuring the oil clearance.



/110010047

6. Remove the main bearing cap and measure the plastic gauge at each journal. If the oil clearance exceeds the maximum value, grind the crankshaft and use the undersized main bearing.

**Oil clearance :**

No.1, 2, 4, 5 : 0.038-0.071 mm(0.0015~0.0028 in.)

No.3 : 0.060-0.093 mm(0.0024~0.0037 in.)

**Limit :**

No.1, 2, 4, 5 : 0.11 mm(0.0043 in.)

No.3 : 0.15 mm(0.0059 in.)

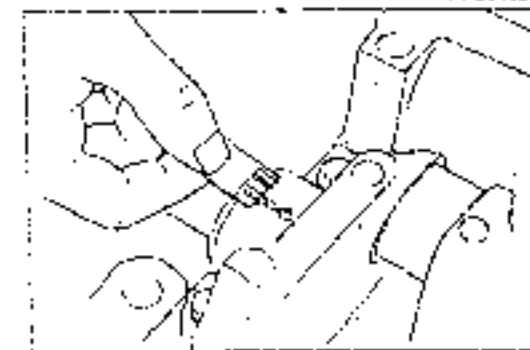

AN7310A153

7. Apply a liberal amount of oil to the main bearing, thrust bearing and main journal.
8. Loosen after tightening with 79 N·m(6.0 kg-m, 58 lb-ft) and retighten with 44 N·m(4.5 kg-m, 33 lb-ft); then tighten 90° again.

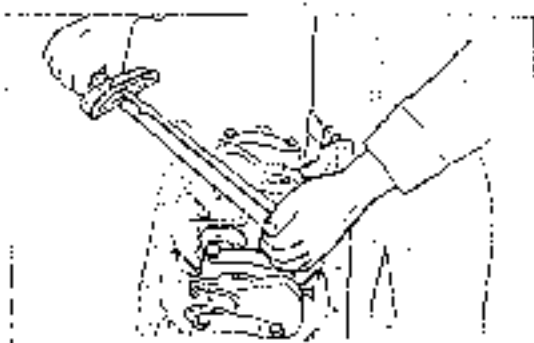

AN7010A183

9. Check the crankshaft end play.

**End play : 0.14-0.30 mm(0.0055-0.0118 in)**  
**Maximum : 0.32 mm(0.0125 in)**

10. If the end play exceeds the maximum value, grind the crankshaft and use the oversized thrust bearing, or replace the crankshaft and thrust bearing.

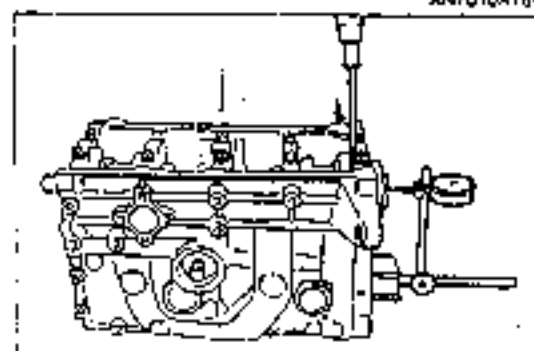

AN7010A165

**Thrust bearing width**

mm(in)

Oversize	Specification
Standard	2.320-2.325(0.0913-0.0915)
0.25	2.445-2.450(0.0962-0.0964)
0.50	2.570-2.575(0.1012-0.1014)
0.75	2.695-2.700(0.1061-0.1063)

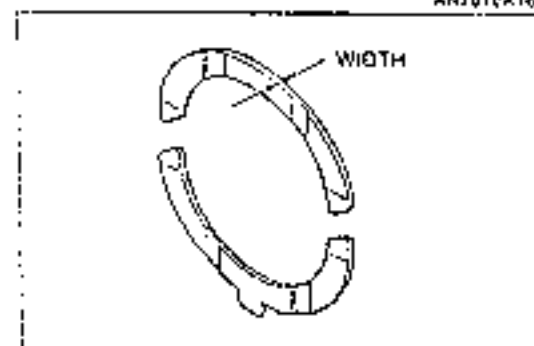

AN7010C162

**Crank pin oil clearance / connecting rod side clearance**

1. Place a piece of plastigauge on the crankshaft at connecting rod journal.

**Caution**

- Do not rotate the crankshaft when measuring the oil clearance.

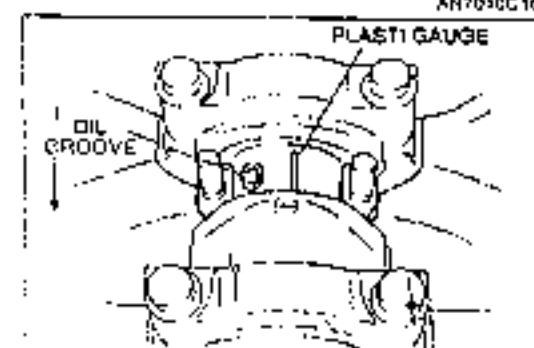

AN7010D16

2. Remove any dirt or other material from the contact surface of the connecting rod bearing and connecting rod bearing cap.
3. Install the connecting rod bearing and the connecting rod cap, aligning the matching marks on the connecting rod and connecting rod cap.
4. Tighten the connecting rod cap nut as follows.
  - (1) Apply engine oil to the thread of connecting rod and the surface of tightening nut, and tighten to 69 N·m(7.0 kg-m, 51 lb-ft) then loosen it.
  - (2) Retighten with 44 N·m(4.5 kg-m, 33 lb-ft) then tighten 90° again.

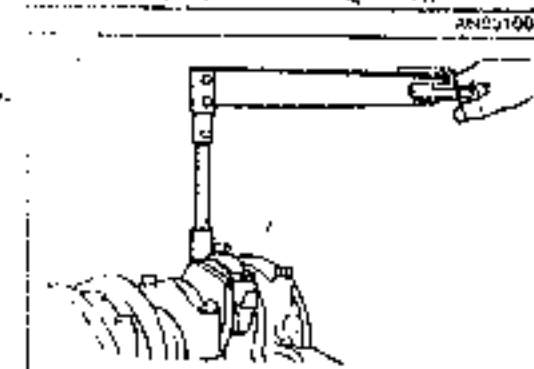

AN7010E10

5. Measure the oil clearance with the plasti gauge after assembling the connecting rod cap.

**Standard : 0.036~0.067 mm(0.0014~0.0026 in)**  
**Limit : 0.10 mm(0.0039 in)**

If it exceeds the limit value, replace the bearing or use the undersized bearing after grinding the crank pin.

mm(in)

Bearing size	Crank pin grinding limit
Standard	57.106~57.124(2.2483~2.2490)
0.25 Under size	56.856~56.874(2.2394~2.2391)
0.50 Under size	56.606~56.624(2.2286~2.2293)
0.75 Under size	56.356~56.374(2.2187~2.2194)

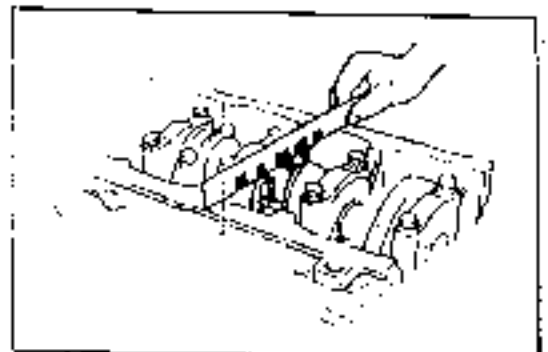

AN8010050

6. Tighten the connecting rod cap as follows.
- (1) Apply engine oil to the lubricating surface of crank pin and connecting rod bearing.
  - (2) Install the connecting rod cap, aligning the matching marks on the cap and on the connecting rod.
  - (3) Tightening order of the connecting rod cap nut

After applying engine oil to the thread of connecting rod tightening bolt and nut, tighten it to 69 N·m(7.0 kg·m, 51 lb·ft), and loosen it. Retighten with 29 N·m(3.0 kg·m, 22 lb·ft) then tighten 90° again.

7. Install a dial gauge.  
 8. Measure the side clearance while moving the connecting rod back and forth.

**Standard : 0.239~0.390 mm(0.0094~0.0153 in)**  
**Limit : 0.25 mm(0.0138 in)**

If it exceeds the limit value, replace the connecting rod and cap.

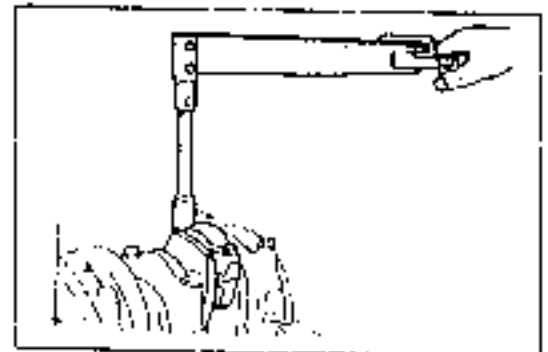

AN8010051

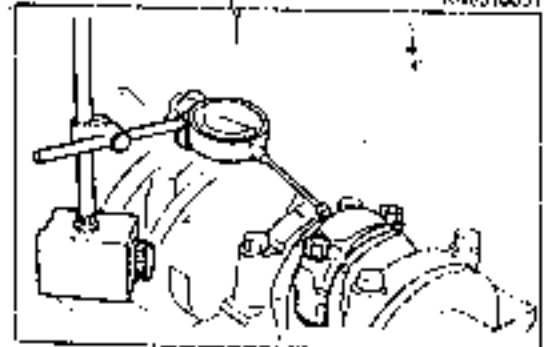

AN8010052

## INSPECTION AND REPAIR

- Clean all parts thoroughly and remove gasket fragments, dirt, oil or grease, carbon, moisture and other foreign material completely.

**Caution**

- Do not give damage to the joints or sliding surface of aluminum alloy parts (cylinder head, piston).

- Check if all parts are suitable with following standard value, replace or repair if necessary.

Item		Specification	Remarks
<b>Cylinder Head</b>			
Distortion of head surface	mm(in)	Longitudinal	0.25(0.010)
		Lateral	0.10(0.004)
Distortion of side surface		mm(in)	0.15(0.006)
Length of cylinder head	Short bolt	Standard	121.7~122.3(4.79~4.81)
		Limit	123.0(4.84)
	Long bolt	Standard	156.7~157.3(6.17~6.19)
		Limit	158.0(6.22)
<b>Valve</b>			
Valve thickness (margin)	mm(in)	Intake	1.35(0.05)
		Exhaust	1.5(0.06)
Valve stem diameter	Intake	Standard	8.468~8.491(0.3333~0.3343)
		Limit	8.395(0.3305)
	Exhaust	Standard	8.440~8.463(0.3323~0.3332)
		Limit	8.369(0.3295)
Valve guide inner diameter		mm(in)	8.518~8.540(0.3354~0.3362)
Oil clearance	mm(in)	Intake	0.027~0.074(0.0011~0.0029)
		Exhaust	0.055~0.100(0.0022~0.0039)
		Limit	0.110(0.0043)
Valve seat angle	[°]	Intake	45
		Exhaust	45
Seat width	mm(in)	Intake	2.41(0.095)
		Exhaust	1.96(0.078)
Valve seat sinking	Standard	Intake	1.05~1.25(0.041~0.049)
		Exhaust	0.90~1.10(0.035~0.043)
	Limit	Intake	2.50(0.087)
		Exhaust	2.50(0.087)
Valve spring length	mm(in)	Standard	49.5(1.95)
		Limit	48.5(1.91)
Valve spring squareness	mm(in)	Limit	1.63(0.064)
<b>Rocker Arm and Rocker Arm Shaft</b>			
Rocker arm inner diameter		mm(in)	19.000~19.021(0.748~0.749)
Rocker arm shaft outer diameter		mm(in)	18.959~18.980(0.748~0.747)
Oil clearance	mm(in)	Standard	0.020~0.062(0.0008~0.0024)
		Limit	0.07(0.003)
<b>Push Rod</b>			
Deflection		mm(in)	0.4(0.016)

Item		Specification	Remarks	
Cylinder Block				
Distortion	mm(in)	Longitudinal	0.254(0.010)	
		Lateral		0.10(0.004)
Cylinder bore inner diameter	mm(in)	X-X axis	97.500-97.513(3.8366-3.8384)	
		Y-Y axis		97.513-97.528(3.8381-3.8396)
Cylinder liner outer diameter	mm(in)	Y-Y axis	97.480-97.493(3.8378-3.8383)	
		Y-Y axis		97.493-97.506(3.8383-3.8388)
Piston, Piston Pin				
Piston outer diameter		mm(in)	94.472-94.498 (3.7194-3.7204)	
Piston clearance		mm(in)	0.030-0.065 (0.0015-0.0026)	
Ring groove clearance	mm(in)	Top ring	0.08-0.10(0.0024-0.0039)	
		Second ring		
		Oil ring		
		Limit		
End gap of piston ring	mm(in)	Top ring	0.30(0.012)	
		Second ring		
		Oil ring		
		Limit		
Piston pin outer diameter		mm(in)	29.994-30.000(1.1809-1.1811)	
Connecting Rod				
Bush inner diameter		mm(in)	30.012-30.033(1.1816-1.1824)	
Oil clearance	mm(in)	Standard	0.012-0.039(0.0005-0.0015)	
		Limit		
Allowable twist		mm(in)	0.05(0.002)	
Camshaft		mm(in)	0.05(0.002) per 100(3.937)	
Rocker				
Cam height	mm(in)	Standard	Intake	0.08(0.0031)
			Exhaust	42.333(1.6667)
		Limit	Intake	42.333(1.6667)
			Exhaust	41.833(1.6470)
Journal diameter (wear limit)	mm(in)	No. 1	51.910-51.940(2.0437-2.0449)	
		No. 2	51.860-51.890(2.0339-2.0350)	
		No. 3	51.410-51.440(2.0240-2.0252)	
		No. 4	51.180-51.190(2.0142-2.0154)	
		Limit	0.08(0.003)	
Camshaft bearing inner diameter	mm(in)	No. 1	52.000-52.030(2.0472-2.0484)	
		No. 2	51.750-51.780(2.0374-2.0386)	
		No. 3	51.500-51.530(2.0276-2.0287)	
		No. 4	51.250-51.280(2.0177-2.0189)	
Oil clearance		mm(in)	0.05-0.12(0.0024-0.0047)	
End plate (axial play)	mm(in)	Camshaft	0.02-0.18(0.0008-0.0070)	
		Idle gear	0.05-0.18(0.0020-0.0070)	
		Limit	0.30(0.0118)	

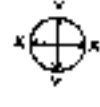

Measured at apex from the lower end of piston

Difference between axial inner diameter of cylinder

Clearance between piston ring groove and piston ring

Measured on all around.

Difference between bush inner diameter and piston

After measuring the journal wear in X and Y direction, replace if it exceeds.

Difference between camshaft bearing inner diameter and camshaft journal outer diameter











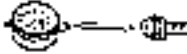

# 10A-32 ENGINE INSPECTION AND REPAIR, SPECIFICATION

Items	Specification	Remarks
<b>Tappe</b>		
Outer diameter	mm(in) 14.219-14.233(0.5608-0.5604)	
Bore in cylinder block	mm(in) 14.288-14.319(0.5625-0.5637)	
Clearance between cylinder block bore and tappet outer diameter	Standard mm(in) Limit	0.058-0.101(0.0022-0.0040) 0.15(0.005)

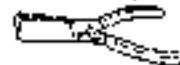
## SPECIFICATION

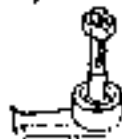
Items	Specification		
Engine	Diesel, 4-Cycles		
Number and arrangement of cylinder	4-Cylinder in-line, Longitudinal		
Combustion chamber type	Swirl		
Total displacement (cc)	2665		
Cylinder bore X stroke mm(in)	94.5 x 95.0(3.7205 x 3.7402)		
Compression ratio	21.5		
Compress pressure (kg/cm <sup>2</sup> -rpm)	30-200		
Valve timing	Intake	Opening	BTDC 12°
		Closing	ABDC 40°
	Exhaust	Opening	BBDC 50°
		Closing	ATDC 12°
Valve clearance mm(in)	Intake	0.30(0.012)(engine cold condition)	
	Exhaust	0.38(0.015)(engine cold condition)	
Idle speed (rpm)	700-750(A/T), 750-790(M/T)		
Injection timing(Static)	ATDC 7°		
Firing order	1-3-4-2		

## SPECIAL TOOLS

OK670 130 010 Cam lift measuring device 	Measuring cam lift amount	OK71E 131 001 Compression gauge adapter 	Measuring compression pressure
OK72A 101 001 Engine hanger 	Fixing engine	OK993 120 001 Valve spring arm 	Replacing valves
OK993 120 004 Pivotal 	Assembling valve	OK993 120 008 Valve seal remover 	Removing valve seal
OK710 120 004 Valve seal installer 	Installing valve seal	OK590 115 001 Ring gear brake set 	Protecting engine from rotating
OK130 150 010 Clutch disc centering tool 	Assembling clutch disc	OK130 111 004 Holder coupling flange 	Removing camshaft gear
OK670 131 005 Injection pump gear remover 	Removing injection pump gear		

# LUBRICATION SYSTEM (J2 ENGINE)

ENGINE OIL .....	11A- 4
OIL COOLER .....	11A- 9
OIL FILTER .....	11A-11
OIL JET .....	11A-11
OIL PAN .....	11A- 7
OIL PRESSURE SWITCH .....	11A-11
OIL PUMP .....	11A- 5
SPECIAL TOOLS .....	11A-12
SPECIFICATION .....	11A-12
TROUBLESHOOTING GUIDE .....	11A- 3

## TROUBLESHOOTING GUIDE

Problem	Possible causes	Action
Engine hard starting	Improper engine oil Insufficient oil	Replace Add oil
Excessive oil consumption	Oil working up to or down from combustion chamber Oil leakage	Refer to Section 10A Repair
Low oil pressure	Insufficient oil Oil leakage Worn or damaged oil pump gear or rotor Worn plunger (in side oil pump), or weak spring Clogged oil strainer Excessive main bearing or connecting rod clearance	Add oil Repair Replace Replace Clean Refer to Section 10A
Warning light on during engine operation	Low oil pressure Malfunction of oil pressure switch Malfunction of electric system	Same as above Replace Repair

## ENGINE OIL

### INSPECTION

1. Be sure that the vehicle is on level ground.
2. Start the engine and let it warm up to normal operating temperature.
3. Turn the engine off and wait for 5 minutes.
4. Check the engine oil level and its condition by using the oil level gauge.
5. Fill or replace oil if necessary.

#### Note

- Check if oil quantity is between "L" and "F" mark of oil level gauge.

### Oil Pressure

1. Remove the oil pressure switch.
2. Connect SST to the attaching hole of oil pressure switch on cylinder block.
3. Start the engine and let it warm up to normal operating temperature.
4. Read the gauge indicating during keeping engine at 3000rpm.

#### Standard oil pressure :

352.8~431.2 kpa (3.6~4.4 kg/cm<sup>2</sup>, 51.15~62.52 psi)

5. If oil pressure is not as specified standard, inspect each part and repair if necessary.

### REPLACEMENT

1. Warm up the engine.
2. Remove the oil filler cap and oil pan drain plug.
3. Drain the oil into a suitable container.

#### Warning

- Since oil is hot when engine is hot, wait a minute and drain oil carefully.

4. Install a new gasket and tighten the drain plug.

Tightening torque : 32~41 N·m (3.2~4.2 kg·m, 23~30 lb·ft)

5. Add the specified oil into the engine up to "F" level.
6. Tighten the oil filler cap.

Oil pan capacity : 5.7 l (6.0 US qt, 5.0 Imp qt)

7. Check the oil level after running engine.

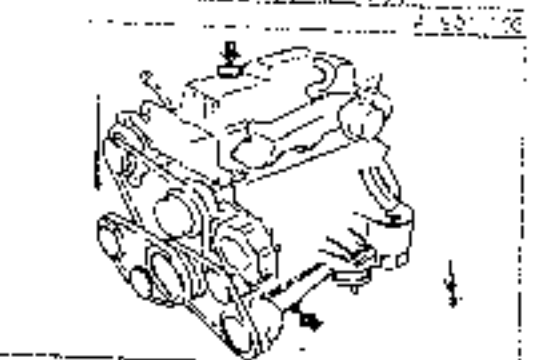
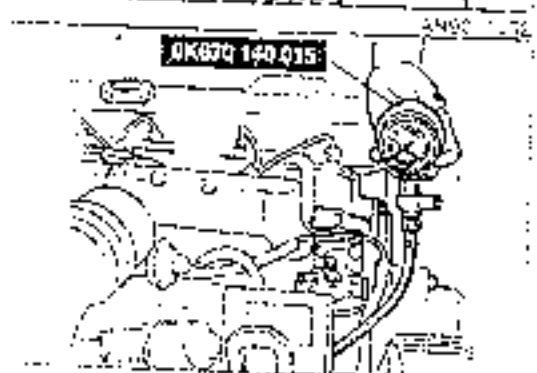
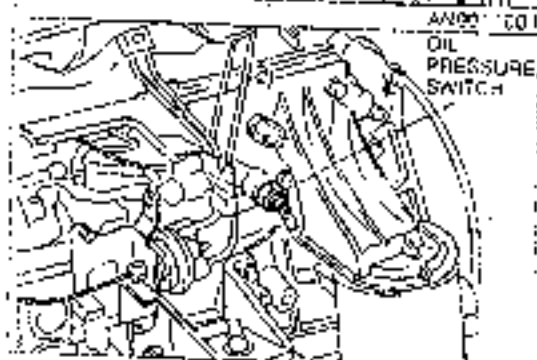
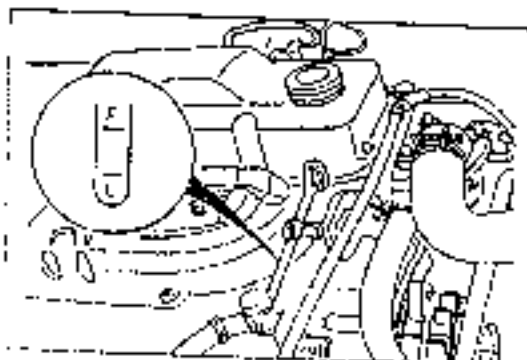

## OIL PUMP

## REMOVAL / INSTALLATION

1. Remove the battery negative cable, then remove the under cover.
2. Drain the oil into a suitable container.
3. Remove each part in steps as shown in the figure.
4. Install in the reverse order of removal.

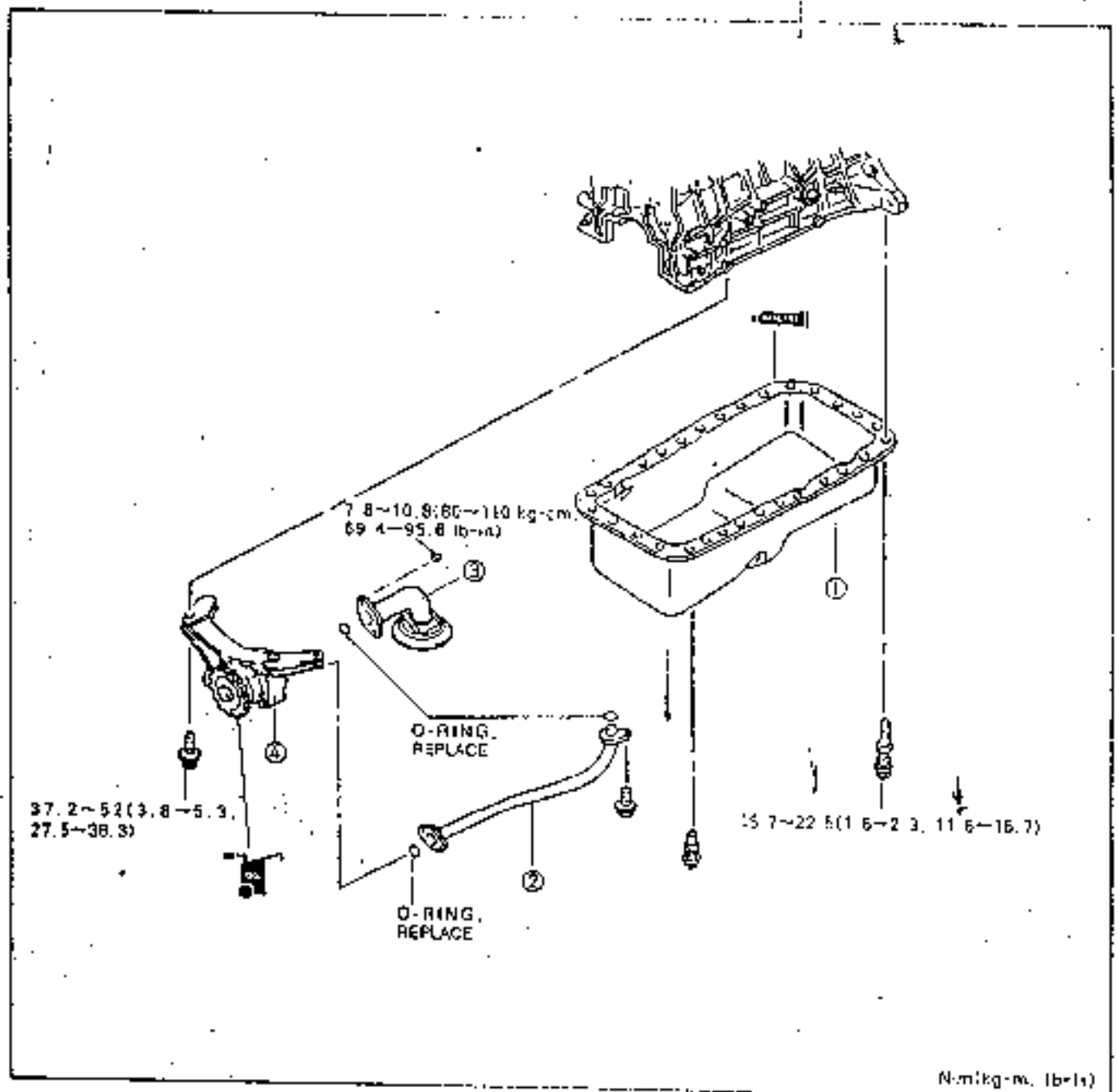

1. Oil pan  
2. Oil pipe

3. Oil strainer  
4. Oil pump

DISASSEMBLY / ASSEMBLY

1. Disassemble in the sequence shown in the figure.
2. Assemble in the reverse order of disassembly.

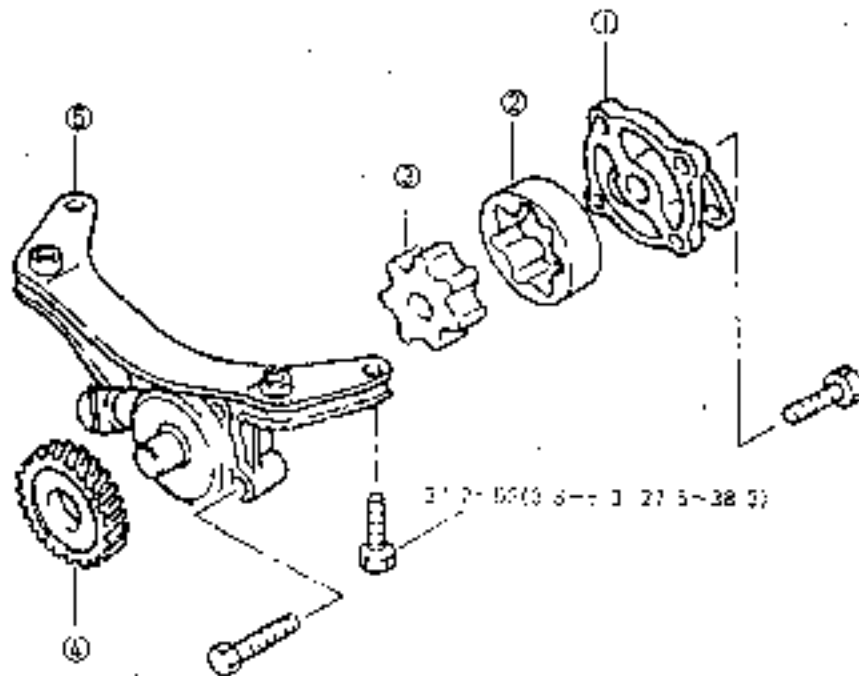

Manitowoc, Inc.

AN90 1006

1. Pump cover
2. Outer rotor
3. Inner rotor

4. Drive gear (using press)
5. Pump body

**INSPECTION**

Inspect the followings, and repair if a problem is found.

1. Distortion or damage of the pump body or cover.
2. Wear or damage of the valve.
3. Weak or crack of the valve spring.

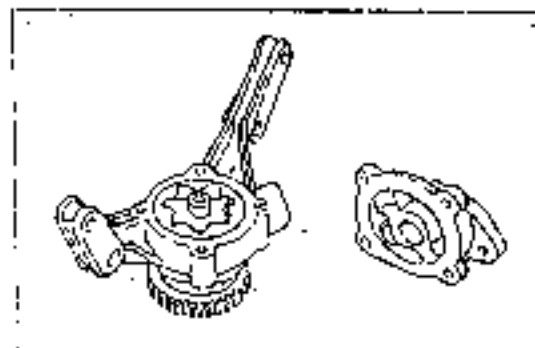

AN901007

4. The clearance between the inner and outer rotor.

Standard : 0.04~0.08 mm(0.0016~0.0031 in)  
Limit : 0.10 mm(0.0040 in)

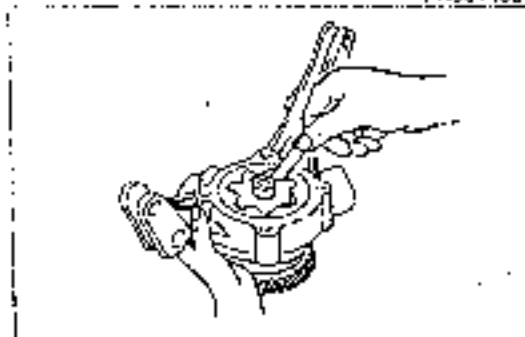

AN901008

5. The clearance between the outer rotor and the pump body.

Standard : 0.10~0.21 mm(0.0040~0.0083 in)  
Limit : 0.25 mm(0.0098 in)

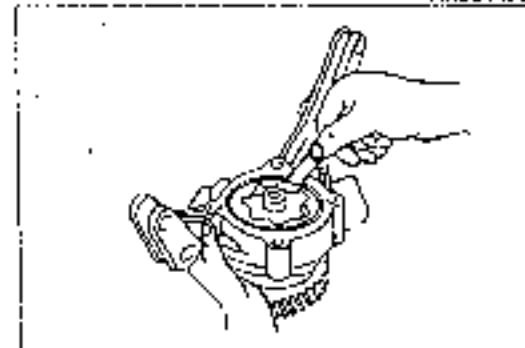

AN901009

6. The clearance between the rotor and the pump cover.

Standard : 0.03~0.10 mm(0.0012~0.0040 in)  
Limit : 0.15 mm(0.0059 in)

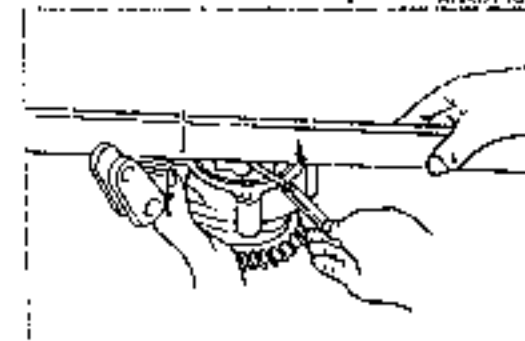

AN901010



## OIL PAN

### REMOVAL

1. Remove the battery negative cable.
2. Drain the engine oil.
3. Remove the under cover.
4. Remove the hose attached to the vacuum pump and far side of oil pan.
5. Remove the oil level gauge pipe from the rubber hose.
6. Remove the oil pan.

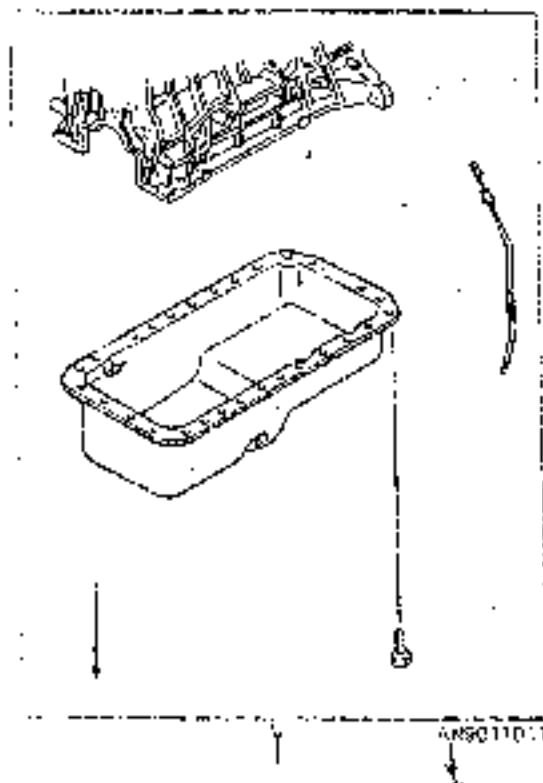

### INSPECTION

1. Remove any dirt or chips in the oil pan.
2. Check the oil pan for crack, the thread of drain plug for damage and inspect the bolt holes for damage. Repair or replace if necessary.

### INSTALLATION

1. Remove the old sealant thoroughly on the cylinder block and oil pan.
2. Apply a continuous bead of sealant to the oil pan along the inside of the bolt holes, and overlap the ends.
3. Tighten the oil pan installation bolts with specified torque.

#### Tightening torque :

15.7-22.5 N·m(1.6-2.3 kg-m, 11.6-16.7 lb-ft)



## OIL COOLER

## DISASSEMBLY / ASSEMBLY

1. Drain the engine coolant and oil.
2. Remove the fuel pipe.
3. Disassemble in steps as shown in the figure, assemble in the reverse order of disassembly.
4. Check for any oil leakage after assembling.

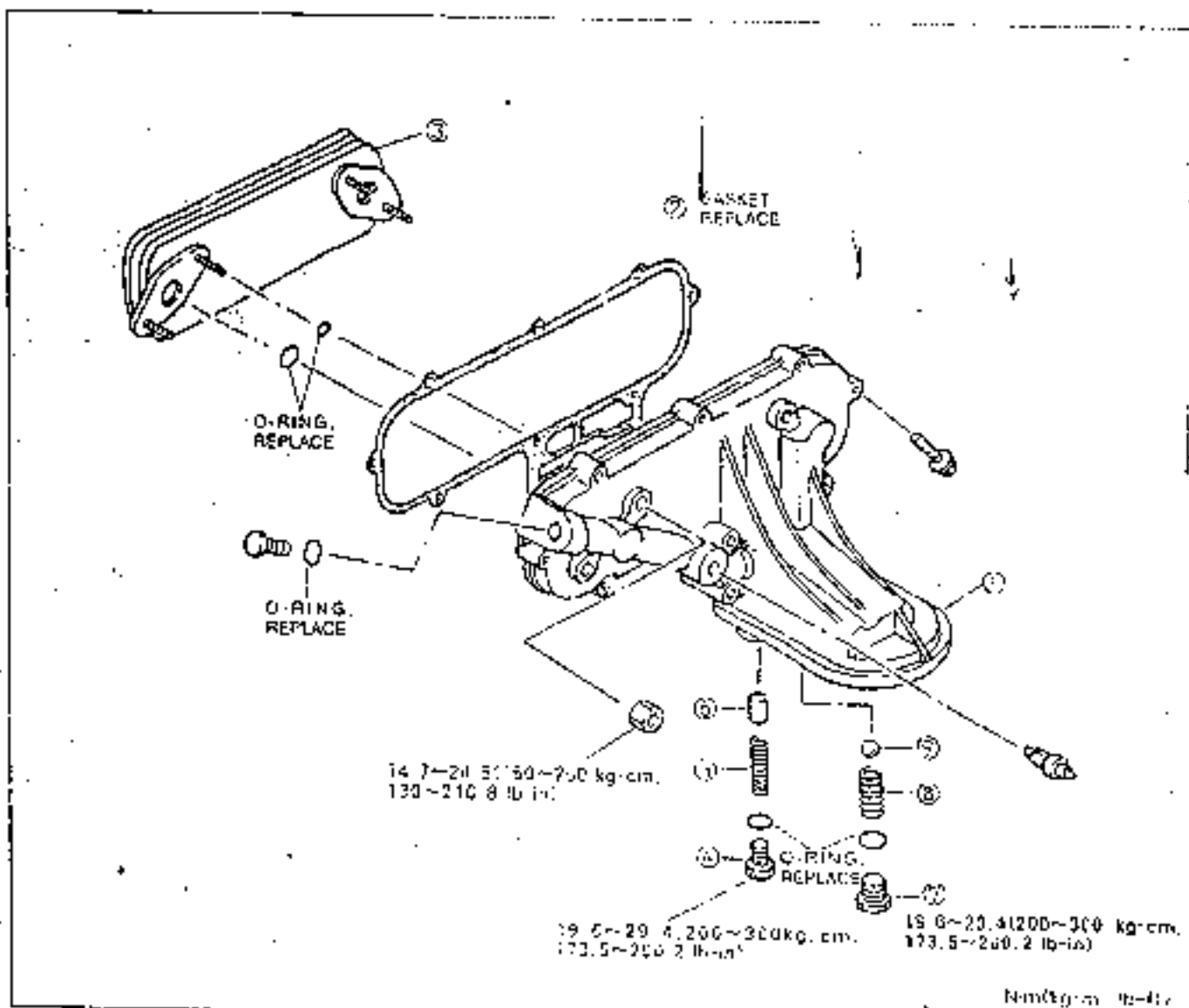

1. Oil cooler cover
2. Gasket
3. Oil cooler

4. Plug
5. Control spring
6. Plunger

7. Plug
8. Relief valve spring
9. Steel ball

A19511012

## 11A-10 LUBRICATION SYSTEM OIL COOLER

### INSPECTION

#### Oil Cooler

1. Inspect visually the core for clogging or damage, and replace it if a problem is found.

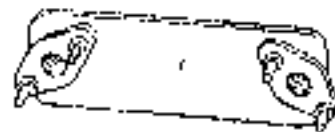

#### Plunger Control

1. Check the plunger control for connection or wear.
2. Check the plunger control spring for weak.

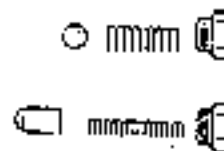

#### Oil Relief Valve

1. Check the steel ball for wear or damage.
2. Check the relief valve spring for weak.

AN9011014

**OIL FILTER****REMOVAL / INSTALLATION**

1. Remove the oil filter by using wrench.
2. Apply a small amount of engine oil to the "O" ring of the new oil filter.

**Caution**

- Do not use any tool for tightening.

3. Tighten the oil filter by hand.

**Tightening torque :**

21.6~24.5 N·m(2.2~2.5 kg·m, 15.9~18.1 lb-ft)

4. Add a specified amount of the engine oil.
5. Start the engine and check for leakage at the filter.

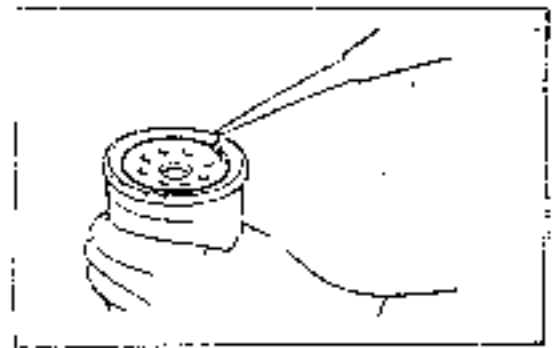

AN-9011315

**OIL PRESSURE SWITCH****INSPECTION**

1. Turn the ignition switch on (no start), then check if the warning light is lit.
2. Start the engine and check if the warning light is turned off.

- The oil pressure switch is normal if it is lit in step 1 and turned off in step No. 2.
- Inspect the electric circuit if it is not lit in step 1, replace the oil pressure switch if no problem is found (refer to the electric wiring diagram).
- Measure the oil pressure if it is lit in step 1 and not turned off in step No. 2, replace the oil pressure switch if the oil pressure is normal.

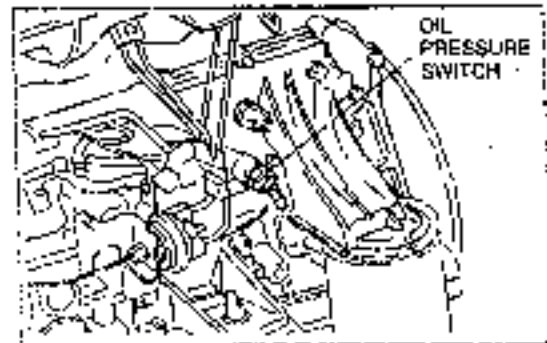

AN-9011692

**OIL JET****INSPECTION**

1. Check the oil passage for clogging.
2. Check the oil jet valve spring for damage.

Valve opening pressure : 196 kpa(2.0 kg/cm<sup>2</sup>, 28.4 psi)

OIL JET

OIL JET VALVE

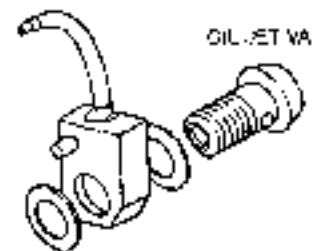

AN-9011016

**SPECIFICATION**

Item		Specification
Lubrication system		Force-fed by gear pump
Total oil quantity		7 (US qt, Imp qt)
Oil quantity in oil pan (F position)		6.7 (6.0, 5.0)
Force-fed pressure		353-432 (3.6-4.4, 5.1-6.3) × 3000rpm
Oil pump		Trochoid type
Oil filter body	Regulating valve opens at	kPa (kg/cm <sup>2</sup> , psi)
	Oil filter relief valve opens at	kPa (kg/cm <sup>2</sup> , psi)
	Oil cooler relief valve opens at	kPa (kg/cm <sup>2</sup> , psi)
Oil filter		Full-flow, paper element
Oil cooler		Built-in water cooled multi-plates type
Warning light operating pressure		29 (0.3, 4.3)
Engine oil		API Service CF-4 or CG-4 Four seasons : SAE, 15W-30 (-25℃~30℃) Four winter : SAE, 10W-30 (20℃~30℃) Four summer : SAE, 30 (0℃~30℃)

**SERVICE SPECIAL TOOL (SST)**

DK870 140 015 Oil pressure gauge		Measurement of oil pressure
--	---	--------------------------------

# COOLING SYSTEM (J2 ENGINE)

12A

ENGINE COOLANT .....	12A- 4
RADIATOR CAP .....	12A- 4
SPECIFICATION .....	12A- 5
THERMOSTAT .....	12A- 5
TROUBLESHOOTING GUIDE .....	12A- 3

## TROUBLESHOOTING GUIDE

Problem	Possible causes	Action
Coolant leaks	Damaged radiator core Coolant leaks from radiator hose and heater hose Coolant leaks from water thermo switch Malfunction of water seal (water pump) Loose or damaged thermostat cover and gasket Loose cylinder head bolts Damaged cylinder head gasket Crack of cylinder block Crack of cylinder head	Replace Repair or Replace Repair or Replace Replace Repair or Replace Tighten Replace Replace Replace
Corrosion	Impurities or deposits in coolant	Clean
Overheating	Clogged water jacket (water passage) Malfunction of thermostat Clogged radiator fins Malfunction of water pump Insufficient coolant Malfunction of thermo modulator fan	Clean Replace Repair or Replace Replace Add Replace

## ENGINE COOLANT

### INSPECTION

#### Coolant Level and Condition

1. Check the coolant level is near the radiator filler neck.
2. Check the level is between FULL and LOW of the reservoir tank. Add coolant as required.
3. Check the radiator cap and radiator filler neck for corrosion or scales.
4. Inspect for oil in either the reservoir tank or radiator filler neck. If oil is found in either place, it is likely there is a leaking head gasket.
5. Inspect for coolant leakage at the radiator, if necessary, repair or replace radiator.

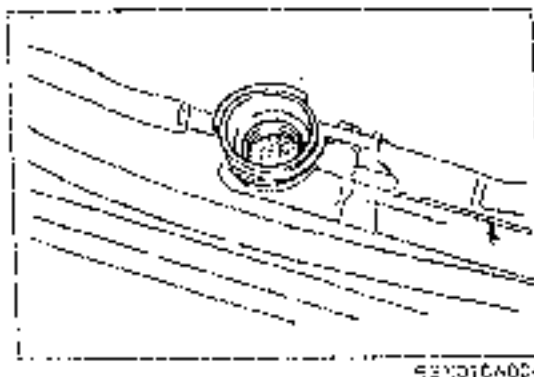

### REPLACEMENT

#### Warning

- Do not open the radiator cap when engine is hot.
- When opening the radiator cap, wrap it with thick cloth.
- Drain hot coolant carefully.

1. Remove the radiator cap and loosen the drain plug
2. Drain coolant into a suitable container.
3. Tighten the drain plug.
4. Add a sufficient amount of anti-freeze solution (Ethylene glycol) and coolant.

#### Coolant capacity

Without heater : 8.5 l (8.98 qt)

With heater : 9.5 l (10.04 qt)

5. Add coolant upto the radiator filler neck during operating the engine at idle.
6. Install the radiator cap.

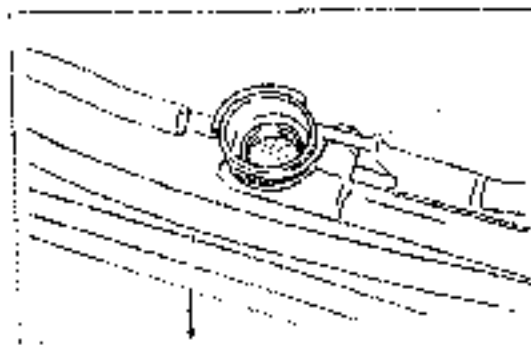

## RADIATOR CAP

### INSPECTION

#### Radiator cap valve

1. Remove foreign material from between the radiator cap valve and the valve seal.
2. Attach the radiator cap tester to the radiator cap, and apply pressure gradually upto 93~123 kpa(0.95~1.25 kg/cm<sup>2</sup>, 13.5~17.8 psi)
3. Wait about 10 seconds. Check that the indicated pressure has not decreased. Replace the radiator cap if the pressure has leaked off.

#### Radiator pressure valve

1. Pull the negative pressure valve to open it, and check if it closes completely when released.
2. Check for damage on contact surfaces and for cracked or deformed seal packing.
3. Replace the radiator cap if necessary.

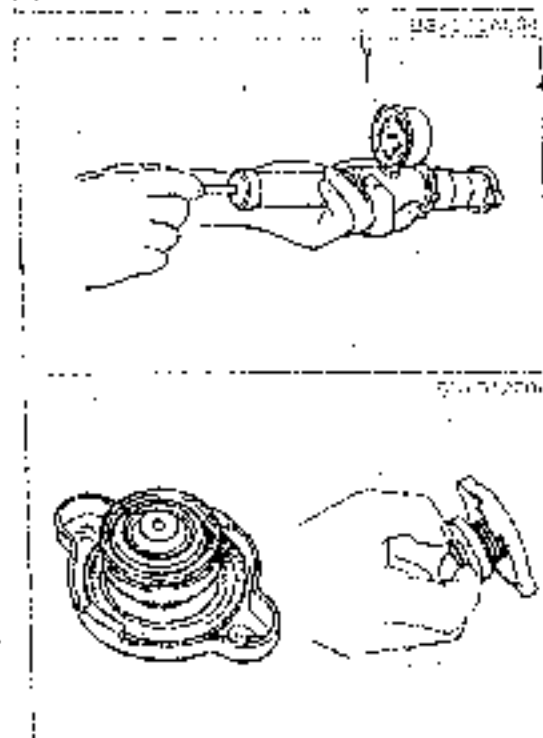

REYN01CA004



# THERMOSTAT

## INSPECTION

1. Check the thermostat valve visually for air tightness.
2. Place the thermostat and a thermometer into water.
3. Heat the water gradually and check the following.

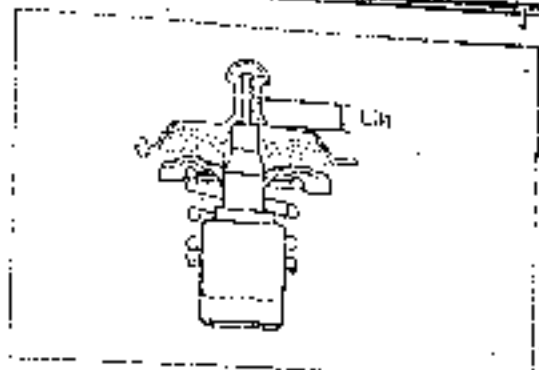

95X112090

Items		Specification
Initial opening temperature	°C (°F)	60.5-83.5(176.9-182.3)
Full-open temperature	°C (°F)	95(203)
Full-open lift	mm (in)	above 6.5(0.33)

## SPECIFICATION

Items		Specification
Thermostat	Type	Wax type
	Initial opening temperature	°C (°F) 60.5-83.5(176.9-182.3)
	Full-open temperature	°C (°F) 95(203)
	Full-open lift	mm (in) above 6.5(0.33)
Coolant capacity (qt)	With heater	9.9(10.0)
	Without heater	8.5(9.0)

# INTAKE AND EXHAUST SYSTEM (J2 ENGINE)

20

EXHAUST SYSTEM .....	20A- 8
INTAKE SYSTEM .....	20A- 9
SPECIFICATION .....	20A- 6

## INTAKE SYSTEM

### REMOVAL / INSTALLATION

1. Remove in the steps shown in the figure.
2. Inspect all parts, and repair or replace if necessary.
3. Install in the reverse order of removal.

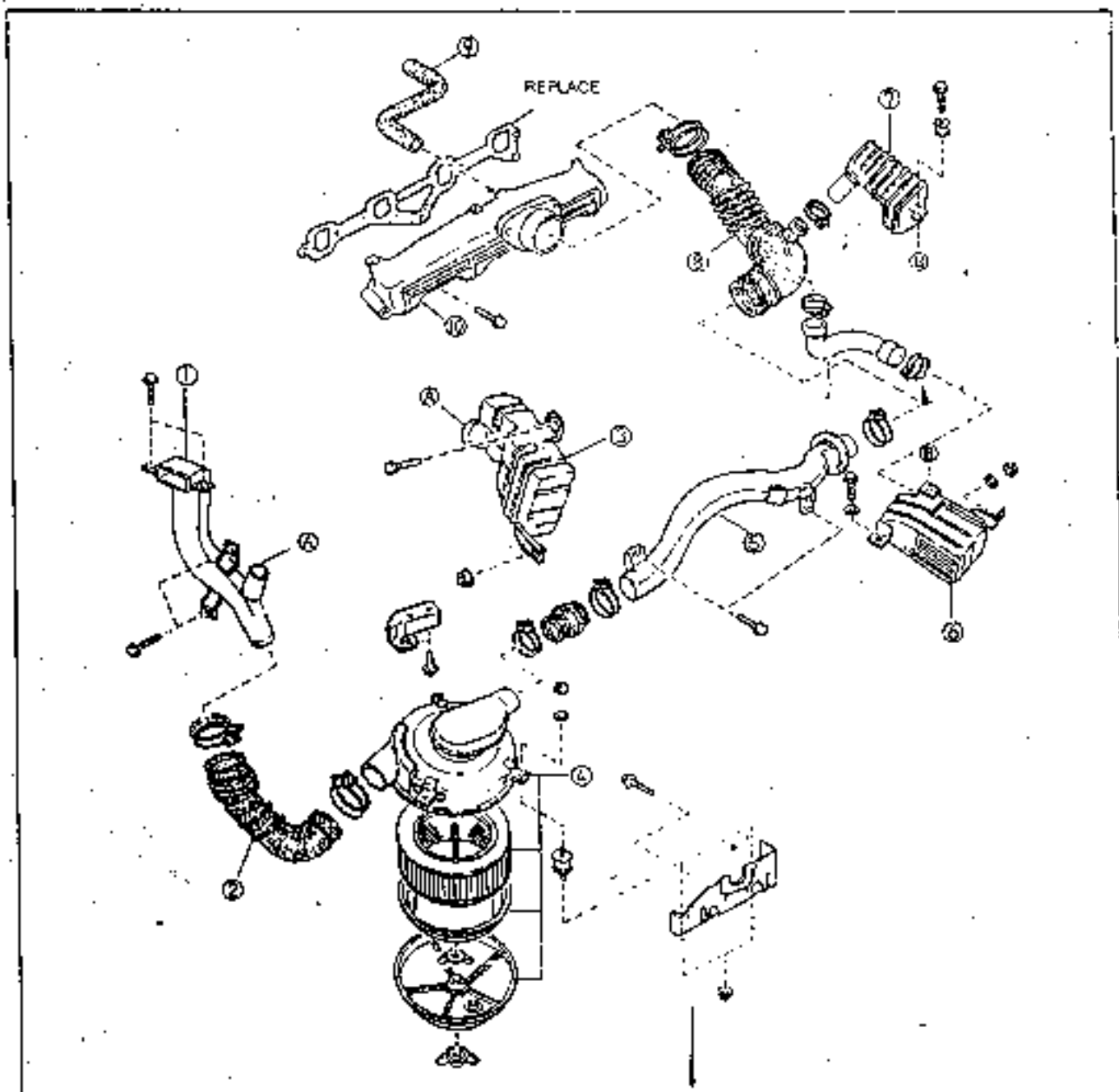

1. Fresh air duct
2. Air hose
3. Resonance chamber
4. Air cleaner

5. Air inlet pipe
6. Resonance chamber
7. Resonance chamber
8. Air inlet hose

9. P/V hose
10. Intake manifold

AN9020002

Accelerator Cable

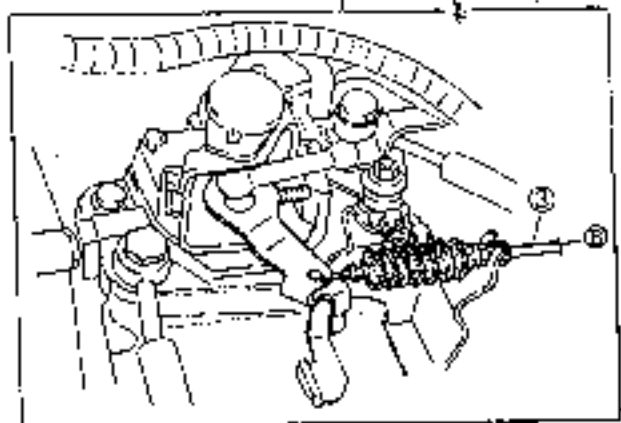
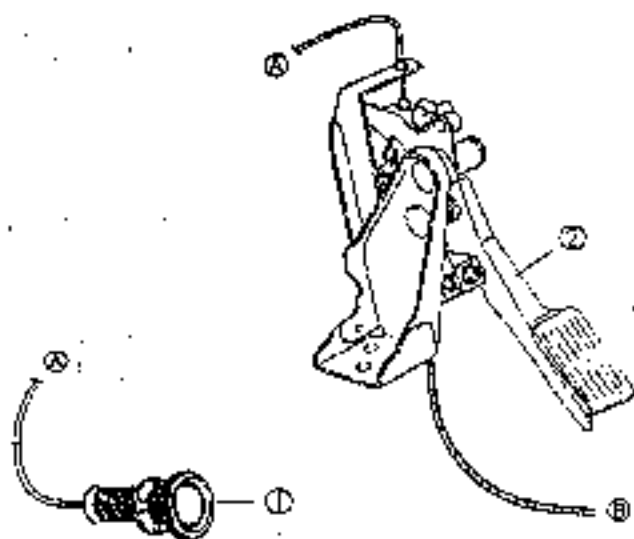

1. Idle adjusting knob

2. Accelerator pedal

3. Accelerator cable

AN902001

**INSPECTION**

**Accelerator Cable**

1. Inspect the cable deflection.

Deflection : 1~3 mm (0.04~0.12 in)

If it exceeds the limit, adjust by rotating the nut (A).

2. Depress the accelerator pedal fully, and check if the control lever touches the stopper bolt.

Clearance : 0 mm

Adjust it by rotating the nut (A) if necessary.

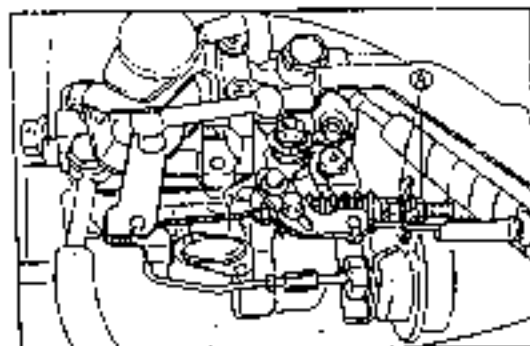

AN902006

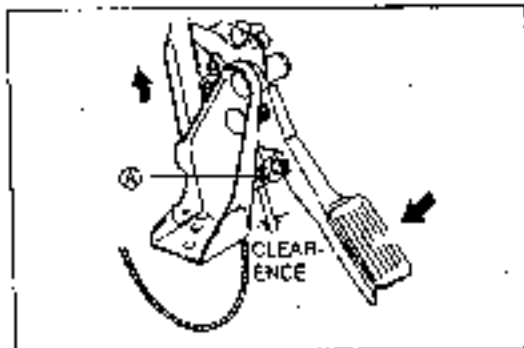

AN902004

**EXHAUST SYSTEM**

1. Remove in the steps shown in the figure.
2. Inspect all parts, and repair or replace if necessary
3. Install in the reverse order of removal.

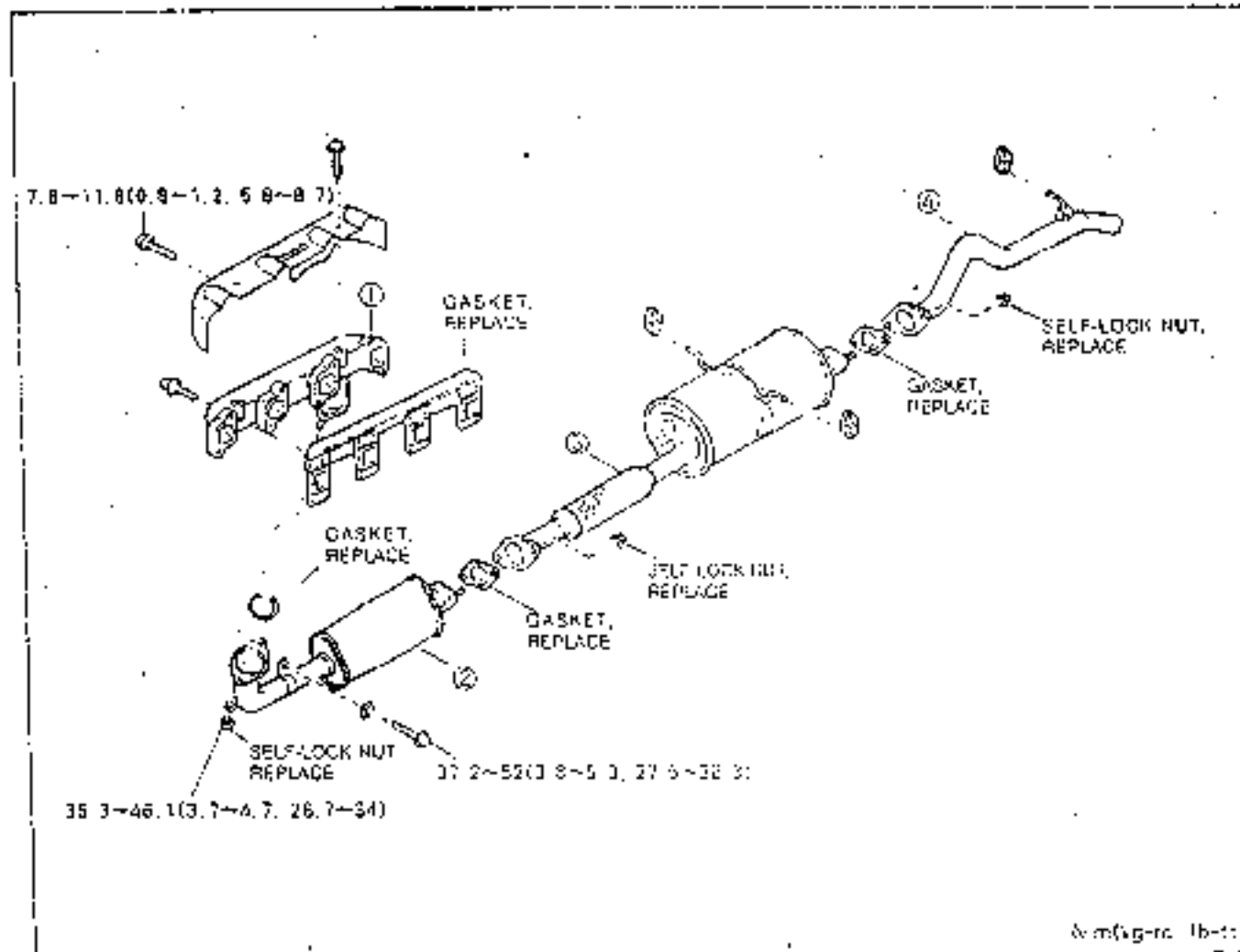

1. Exhaust manifold
2. Front pipe (combined with the pre-silencer)

3. Main silencer (combined with the bellows)
4. Tail pipe

**SPECIFICATION**

Items	Type	Specification
Air Cleaner	Type	Paper Element
Accelerator Cable	Deflection	7.62 (3.0)

Items	Type	Specification
Air Cleaner	Type	Paper Element
Accelerator Cable	Deflection	7.62 (3.0)

# FUEL SYSTEM (J2 ENGINE)

22A

FAST IDLE CONTROL DEVICE (FICD) .....	22A-13
FUEL CUT VALVE .....	22A-10
FUEL FILTER (BUILT-WITH SEDIMENTOR) .....	22A- 8
FUEL INJECTION NOZZLE .....	22A-11
FUEL TANK .....	22A- 6
INJECTION PUMP .....	22A- 7
OUTLINE .....	22A- 3
PICKUP COIL .....	22A-10
SPECIAL TOOLS .....	22A-15
SPECIFICATION .....	22A-16
TROUBLESHOOTING GUIDE .....	22A- 4

OUTLINE

STRUCTURAL VIEW

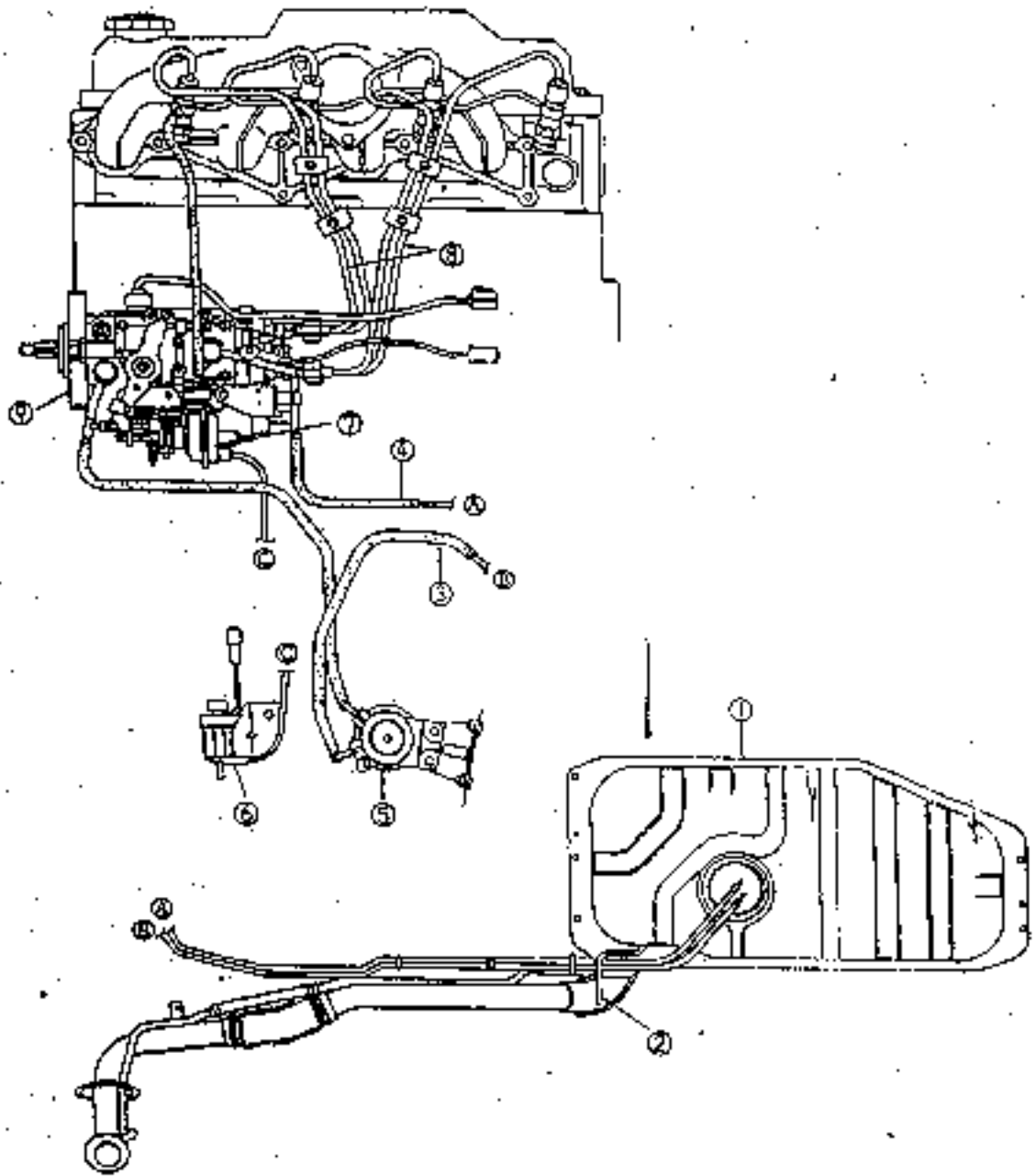

- 1. Fuel tank
- 2. Check valve
- 3. Main hose

- 4. Return hose
- 5. Fuel filter (built-with sedimentator)
- 6. Solenoid valve (3-way)

- 7. Actuator
- 8. Injection pipe
- 9. Injection pump

AN9022001

## TROUBLESHOOTING GUIDE

Problem	Possible causes	Action
Failure of engine starting	Fuel filter Clogged Water or air in filter Injection pump Fuel cut valve malfunctioning Improper injection timing Air in pump Malfunction of parts in pump Fuel injection nozzle Stuck needle valve Fuel leakage from nozzle Improper nozzle opening pressure Malfunction of glow plug	Replace Repair  Replace Adjust Repair Replace  Replace Replace Adjust Replace
Rough idle	Fuel filter Refer to Failure of engine starting Injection pump Refer to Failure of engine starting Fuel injection nozzle Stuck needle valve Improper nozzle opening pressure Improper installation of nozzle holder Leakage from nozzle holder washer Fuel injection pipe Crack Leakage from connection Improper adjustment for idle speed	   Replace Adjust Repair Replace  Replace Repair Adjust
Knocking	incorrect injection timing Low quality of fuel Improper fuel injection nozzle opening pressure Stuck needle valve of fuel injection nozzle Fuel leakage from fuel injection nozzle	Adjust Replace Adjust Replace Replace
High fuel consumption	Injection pump Incorrect injection timing High idle speed Fuel injection nozzle Improper nozzle opening pressure Fuel leakage from nozzle Fuel leakage from nozzle holder washer Fuel leakage from connection Clogged fuel filter	Adjust Adjust  Repair Replace Replace Repair Replace
Poor acceleration	Fuel injection nozzle Improper nozzle opening pressure Stuck needle valve Fuel leakage from nozzle Injection pump Refer to Failure of engine starting Fuel injection pipe Refer to Rough Idle Fuel filter Water or air in filter Clogged	Replace Replace Replace      Replace or Repair Replace
Excessive exhaust smoke	Clogged air cleaner Incorrect injection timing Malfunction of nozzle or nozzle holder	Clean or Replace Adjust Repair or Replace



# FUEL TANK

## REMOVAL / INSTALLATION

### Warning

- Isolate all explosive sources during removing the fuel tank.
- When repairing the fuel tank, remove all fuel thoroughly in the tank.

### Note

- Check the fuel tank for crack or wear, and repair or replace if necessary.
1. Remove the battery negative cable and the fuel cut solenoid valve connector.
  2. Raise the vehicle up by jack and support it with safety stand.
  3. Drain fuel by removing the drain plug, remove in the steps shown in the below figure.
  4. Install in the reverse order of removal.

### Note

Check the following after installation.

- Fuel hose for correct installation.
- Fuel leakage

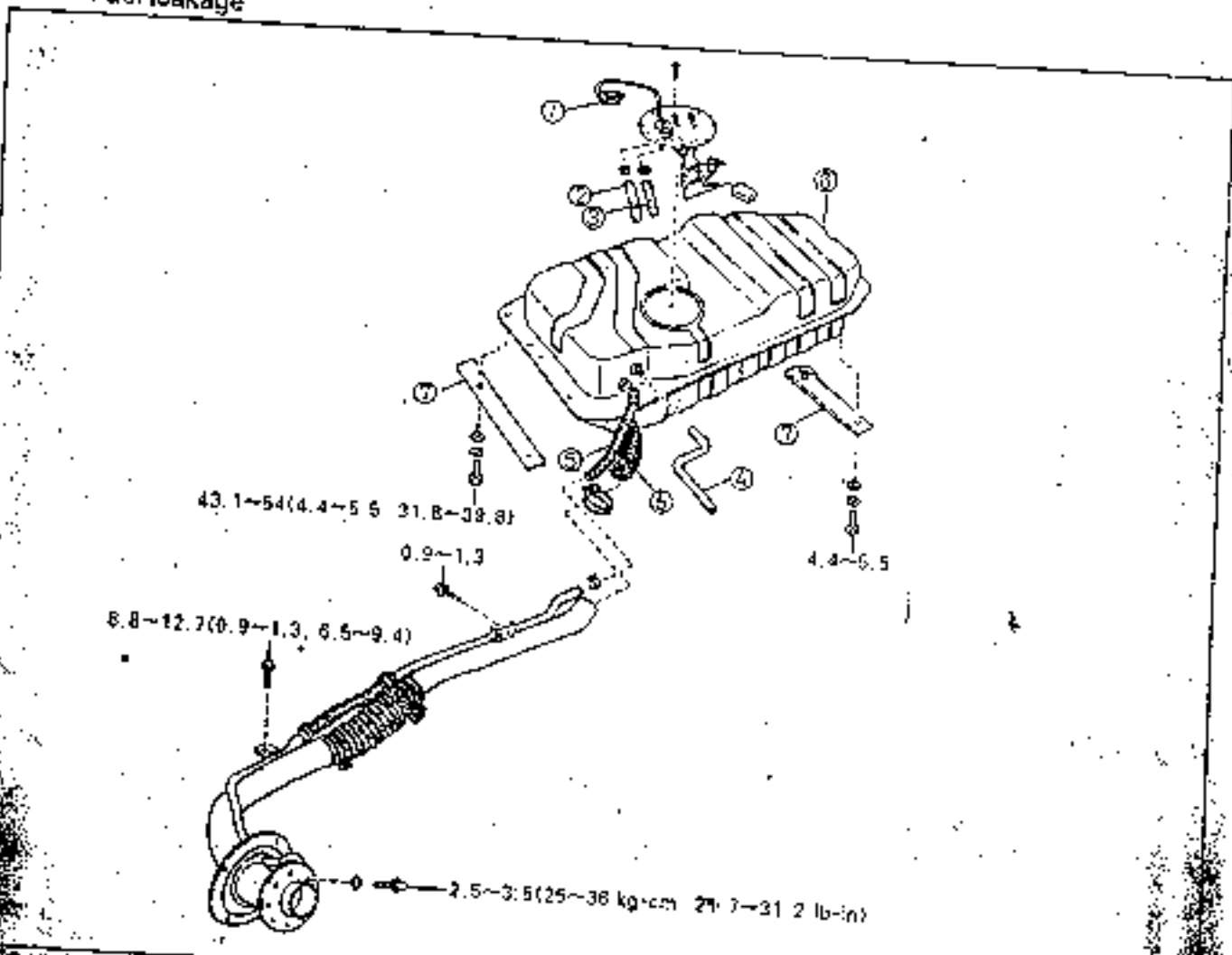

Fuel level gauge connector  
 Return hose  
 Main hose

4. Ventilation hose (built-with check valve)  
 5. Bleeder hose  
 6. Joint hose

7. Fuel tank bracket  
 8. Fuel tank assembly

ANG0003

## 22A-6 FUEL SYSTEM FUEL TANK, FUEL FILTER (BUILT-WITH SEDIMENTOR)

### INSPECTION

#### Check Valve (2-Way)

1. Remove the hose from the fuel tank.

#### Note

- Check any foreign material in hose.

2. Inspect air flow in both direction.
3. If it exceeds the specification, replace the hose assembly.

#### Warning

- Do not inhale fuel.

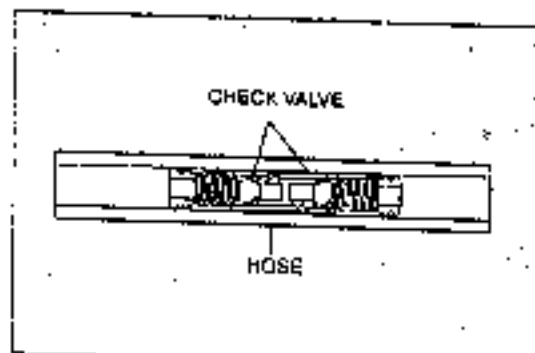

AN9022003

## FUEL FILTER (BUILT-WITH SEDIMENTOR)

### AIR BLEEDING

#### Caution

- In case that air is present in the injection system because of lack of fuel during engine operation, or the injection pump is replaced, air bleeding should be performed according to the following procedures, and then start engine and verify if fuel is not leaked.

1. Remove the fuel filter air bleeding plug ④.
2. Depress and release repeatedly the head of fuel filter until only fuel flows out.
3. Install the air bleeding plug while depressing the head of fuel filter.

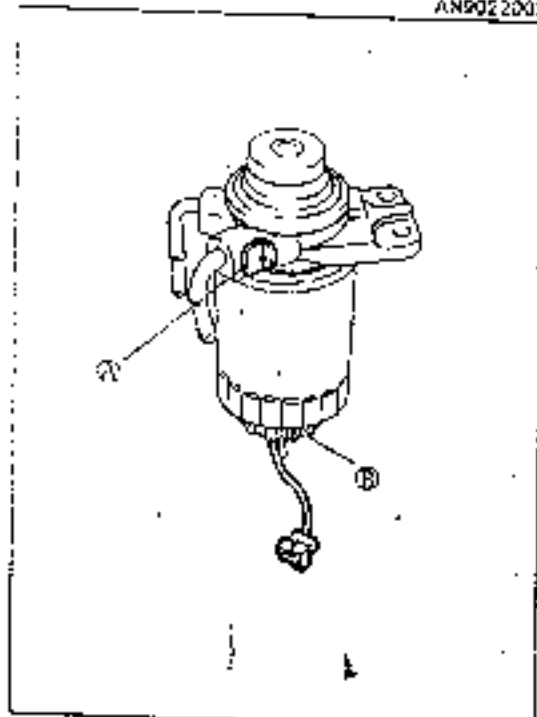

AN9022104

### DRAINING WATER

#### Note

- If the sedimentor warning light is lit, drain the water in the steps as shown below.

1. Remove the drain plug, and then drain the water while depressing and releasing repeatedly the head of fuel filter.
2. After draining the water, do air bleeding for the fuel filter.

### DETECTOR

1. Remove the detector from the sedimentor.
2. Do the continuity test and verify that it is closed if the detector is moved upward and opened if downward.

#### Caution

- After installing the detector, air bleeding should be done.

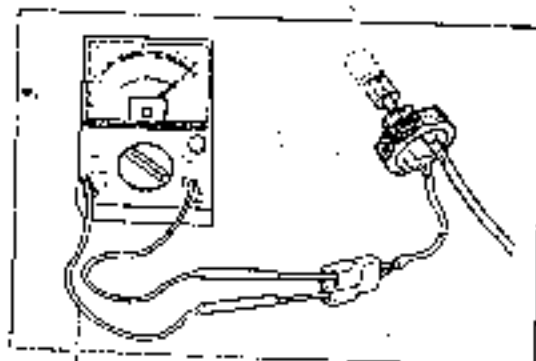

AN9022106

## INJECTION PUMP

## IDLE SPEED

## Inspection

1. Warm up engine upto the normal operating temperature (coolant temperature 80°C(140°F).
2. Connect a tachometer and, check the idle speed.

Idle speed : 700~750 rpm

If the idle speed exceeds the specification, adjust it in the following steps.

## Adjustment

1. Inspect the deflection of accelerator cable.

Deflection : 1~3 mm(0.04~0.12 in)

## Note

- If the deflection exceeds the specification, adjust it while rotating the nut ② after loosening the accelerator cable lock nut ①.

2. After loosening the lock nut ① of idle speed adjusting bolt, adjust idle speed by rotating the adjusting bolt ②.

Tightening torque : 5.9~8.8 N·m(0.6~0.9 kg·m, 4.4~6.5 lb-ft)

## Note

- The idle speed is increased if turning the adjusting bolt clockwise, and decreased if turning it counter-clockwise.
- Check if the adjusting lever is properly operated after adjusting (Refer page 20-4).

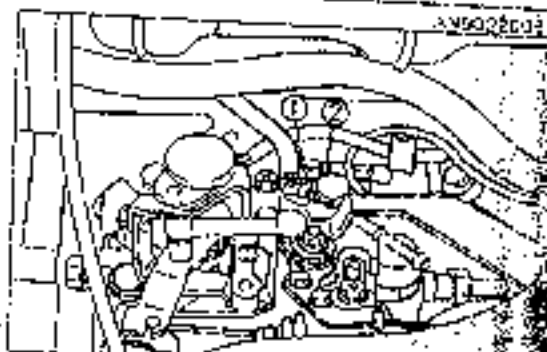
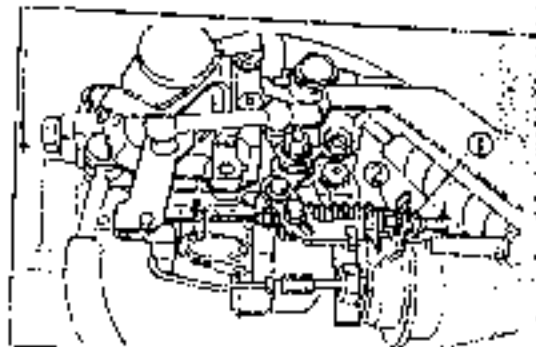

## INJECTION TIMING

## Inspection

1. Remove the battery negative cable and the fuel cut solenoid valve connector.
2. Remove the intake hose.
3. Remove the fuel injection pipe from the injection pump.
4. Align the timing mark (ATDC 7°) on the crankshaft pulley with the indicator pin by rotating the alternator pulley.

5. Remove the hydraulic head plug on the injection pump.
6. Insert SST (OK670 131 010) into the plug hole on the hydraulic head, and install the dial gauge so that its indicator can touch the plunger of pump.

## Note

- Install so that the indicator of dial gauge indicates about 2~3 mm(0.08~0.12 in).

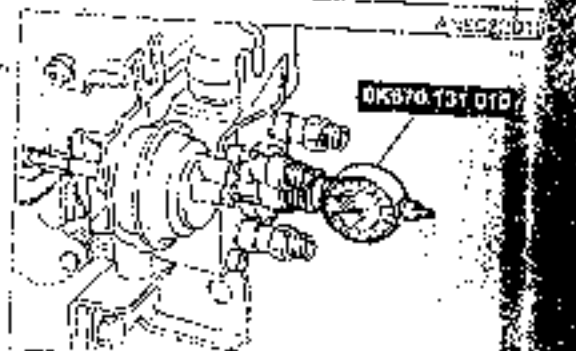
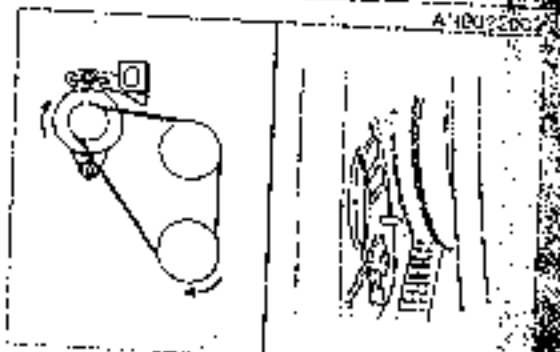

Slowly rotate the alternator pulley counterclockwise (in the reverse direction of engine revolution) until the indicator of dial gauge does not move.

**Note**

The indicator of dial gauge stops when the crankshaft is turned about 30° counterclockwise.

- Align the indicator of dial gauge to "0".

**Note**

After aligning the indicator of dial gauge to "0", verify that the indicator of dial gauge is not moved from "0" by slightly rotating the alternator pulley in left and right.

- After rotating the alternator pulley clockwise (in same direction of engine revolution) so that the timing mark can be aligned with the indicator pin, verify that the indicator of dial gauge indicated  $1 \pm 0.02$  mm ( $0.04 \pm 0.0008$  in) when the timing mark (ATDC 7°) can be aligned with the indicator pin.

If the injection timing is beyond specification, adjust it in the following procedures.

**Adjustment**

- Loosen the nut (B, C) after removing the injection pump installation bolt (A).
- Adjust the injection timing by moving the injection pump until the cam lift is  $1 \pm 0.02$  mm.

Cam Lift	Injection timing	Adjustment
Above $1 \pm 0.02$ mm ( $0.04 \pm 0.0008$ in)	Advanced	Rotate the injection pump counterclockwise (in the reverse direction of engine revolution)
Below $1 \pm 0.02$ mm	Retarded	Rotate the injection pump clockwise (in the direction of engine revolution)

**Note**

Perform the air bleeding after adjusting injection timing.

**CAM LIFT**

**Inspection**

- Perform the injection pump adjusting procedures.
- Rotate the alternator pulley clockwise (in the same direction of engine revolution) and read the maximum indicating of dial gauge indicator.

Cam lift : 2.6 mm (0.102 in)

**Note**

If the cam lift is smaller than specification, there is problem in the cam disc or roller assembly.

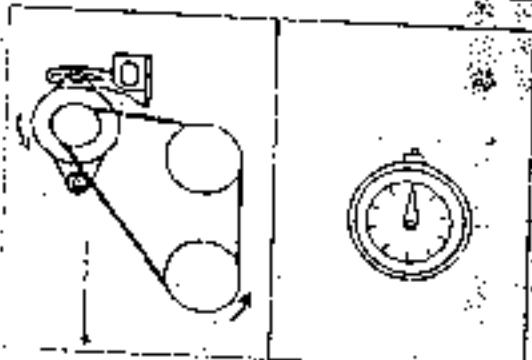

AN9022012

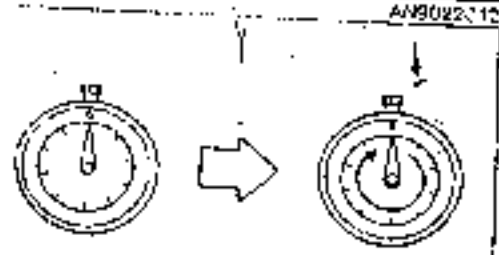

AN9022013

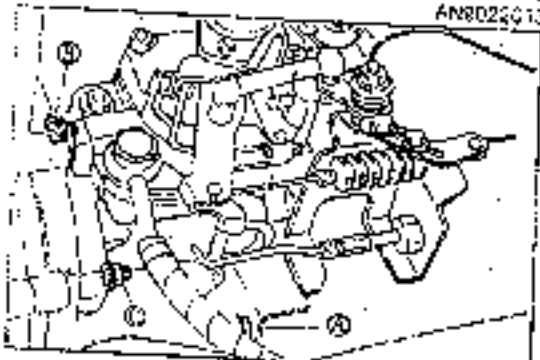

AN9022014

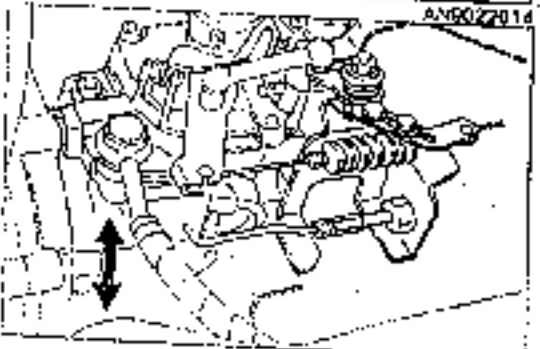

AN9022015



AN9022016

**REMOVAL / INSTALLATION**

1. Remove the battery negative cable.
2. Remove the service cover (Refer to Section 10).
3. Remove in the steps shown in the figure, referring to notes for removal.
4. Inspect all parts, and repair or replace if necessary.
5. Install in the reverse order of removal.

**Caution**

- Check the injection timing, and adjust it if necessary (refer to page 22-7).
- After installation, perform air bleeding from the injection pump.

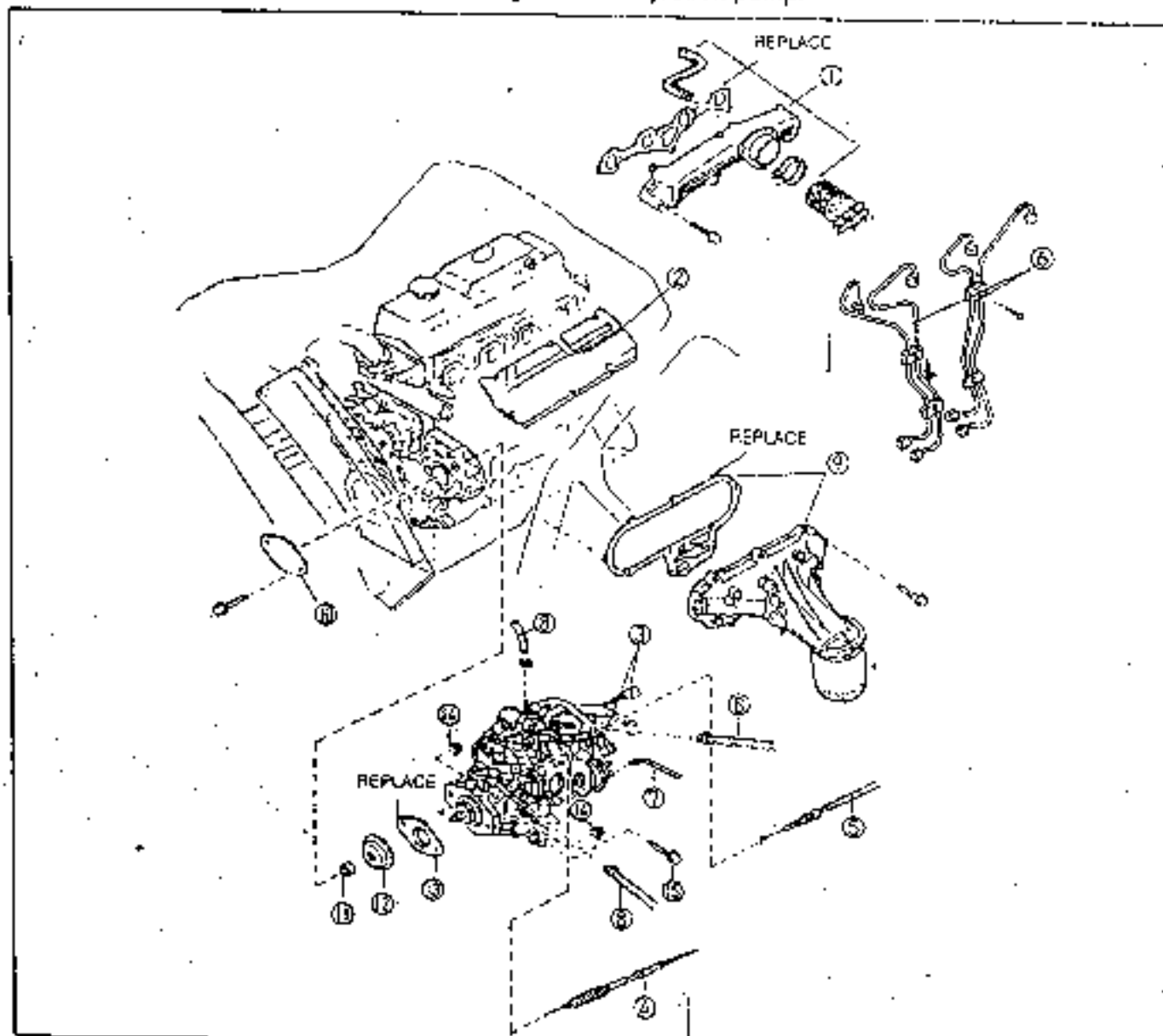

1. PCV hose and intake manifold assembly
2. Nozzle cover
3. Fuel cut valve, pick up coil and throttle position sensor (ATX only) connector

4. Accelerator cable
5. Throttle cable (ATX only)
6. Injection pipe
7. Vacuum hose
8. Fuel hose
9. Oil filler assembly

10. Injection pump cover
11. Nut
12. Washer
13. Gasket
14. Nut
15. Bolt

## 22A-10 FUEL SYSTEM INJECTION PUMP, FUEL CUT VALVE, PICKUP COIL

### Removal note

1. Mark matching line between the injection pump flange and bracket.

2. Remove the injection pump lock nut by using SST (0K670 131 005).

### Caution

- Be careful for damage to the woodruff key attached to the pump.

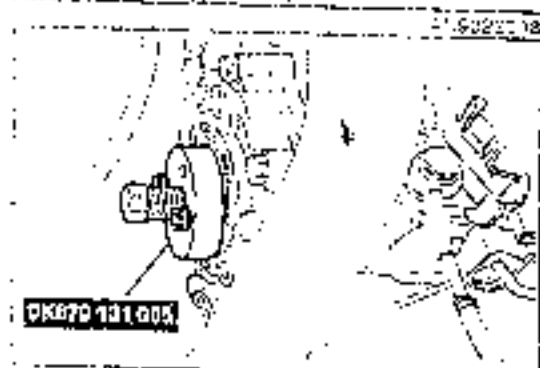

## FUEL CUT VALVE

### INSPECTION

1. Verify that engine stops when disconnecting the fuel cut valve connector during engine operation. If engine does not stop, inspect all related wiring harness, and replace the fuel cut valve if it is normal.

## PICKUP COIL

### INSPECTION

1. Remove the pick up coil connector.
2. Do continuity test by using a ohmmeter.
3. Replace the pick up coil if its circuit is opened.

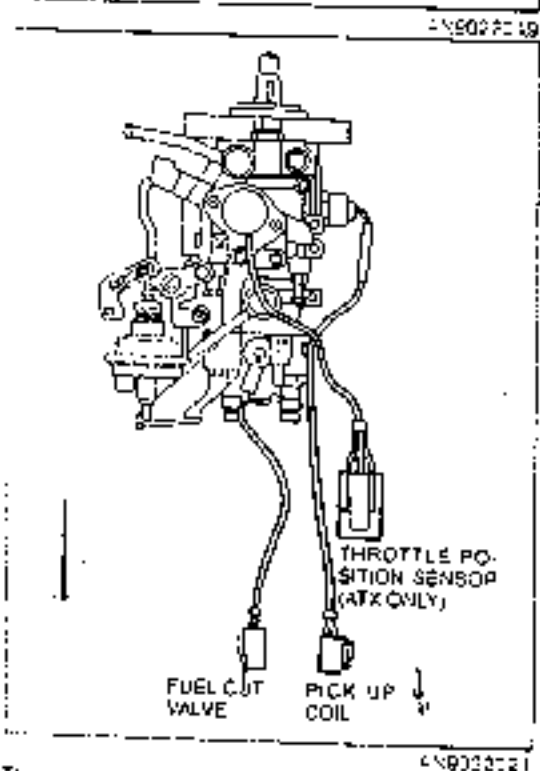

## FUEL INJECTION NOZZLE

### REMOVAL

- Remove in the following steps.
  - Battery negative cable
  - Fuel cut valve connector assembly
  - Fuel injection pipe
  - Fuel return pipe lock nut
  - Fuel return pipe
  - Washer
  - Fuel injection nozzle
  - Nozzle washer
  - Corrugate washer

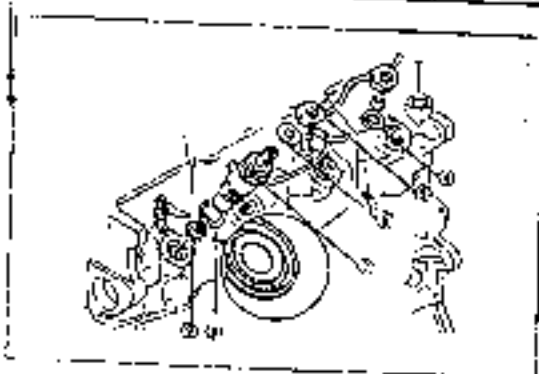

AN7021C021

### INSPECTION

#### Note

- Inspect the fuel injection nozzle by using diesel fuel at about 20°C(68°F)

#### Injection Starting Pressure

- Set the injection nozzle on the nozzle tester and bleed air by pumping handle several times.
- Slowly push down the handle of nozzle tester and check injection starting pressure.

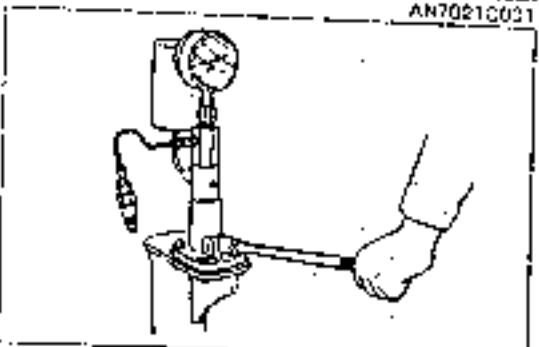

AN7021C033

Injection starting pressure :  
13230 kpa(135 kg/cm<sup>2</sup>, 1918 psi)

- If injection starting pressure is beyond the specification, adjust by using shim.

#### Note

- Shim type : from 0.50mm (0.02 in) to 1.54mm (0.06 in) (27 types in total at interval of 0.04mm(0.0016 in))
- If thickness is increased 0.04mm, injection pressure increases approximately 470 kpa. (4.8 kg/cm<sup>2</sup>, 68 psi)

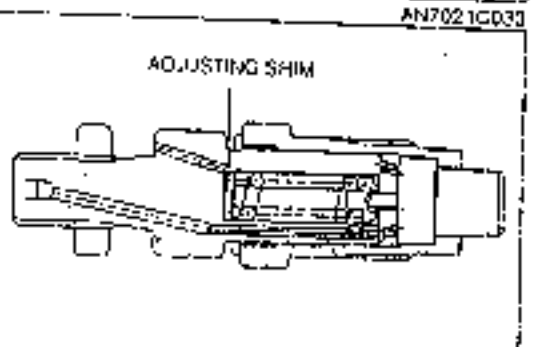

AN7021C034

#### Valve Seat

- Apply a certain pressure 11270 kpa(115 kg/cm<sup>2</sup>, 1554 psi) and check if fuel leaks from the injection nozzle hole. If fuel leaks, disassemble, clean and check injection nozzle again, or replace it.

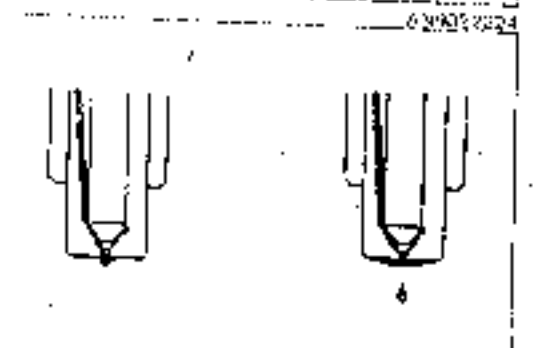

AN7021C035

#### Atomizing Condition (Spray pattern)

- Set the nozzle on the nozzle tester and bleed air by pumping handle several times.
- In condition that pressure is not applied to nozzle, push handle several times quickly (push handle as quickly as possible so that a pulsation noise can be heard) and check atomizing condition.
  - Fuel should be sprayed uniformly and finely.
  - Injection angle and direction should be normal.
- If atomizing condition is abnormal, disassemble, clean and check injection nozzle again, or replace it.

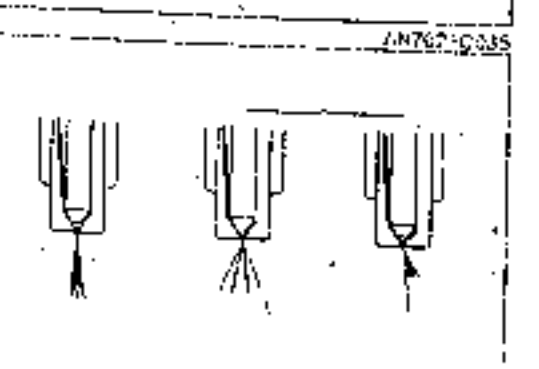

AN7021C036

**NOZZLE BODY AND NEEDLE VALVE**

**Disassembly**

1. Disassemble in the following steps.

- |                                |                 |
|--------------------------------|-----------------|
| ① Retaining ring               | ⑥ Shim          |
| ② Nozzle body and needle valve | ⑦ Nozzle holder |
| ③ Distance piece               | ⑧ Washer        |
| ④ Pressure pin                 | ⑨ Nut           |
| ⑤ Pressure spring              |                 |

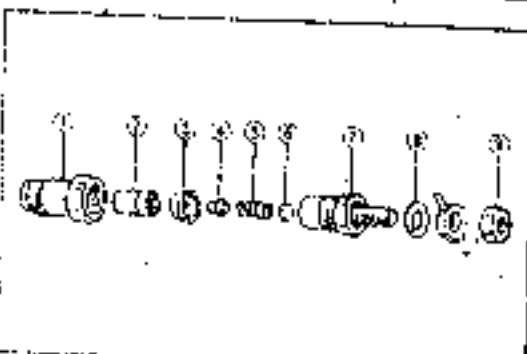

4570210032

**Inspection**

1. Check the valve seat and other parts of needle valve for damage.
2. Check the nozzle body for damage. Grasp the nozzle body vertically and insert about 2/3 of needle valve, then verify that the needle valve falls down to seat by its weight.



4570210037

**Assembly**

When assembling the injection nozzle, be careful for the following.

Tightening torque : 29 N·m(3~5 kg-m, 49 lb-ft)

**Caution**

- After assembling the injection nozzle, inspect the injection starting pressure and atomizing condition.
- Keep the specified torque when assembling the nozzle body and nozzle holder.

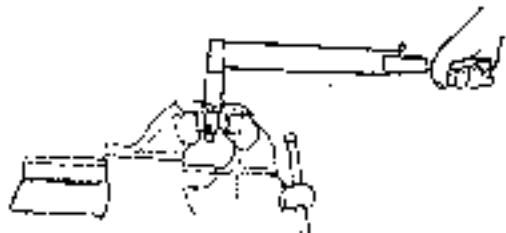

4570210030

**Installation**

1. Install in the reverse order of removal.

**Caution**

- Do not reuse the washer and the corrugated gasket.
- When installing the corrugated gasket, the red-painted surface should be faced to the injection nozzle.
- Keep the specified torque when installing the injection nozzle.
- Bleed air when installing the injection nozzle.

Tightening torque : 5.9 N·m(6~7 kg-m, 69 lb-ft)

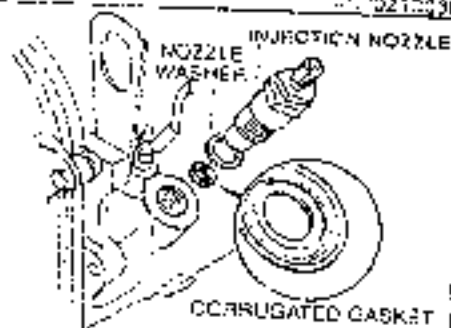

4570210039



## FAST IDLE CONTROL DEVICE (FICD)

### OUTLINE

Vacuum from the vacuum pump is applied to the actuator by the solenoid valve (3-way) when air conditioner is turned on, then pulls the control lever and idle speed increases so that it can be compensated according to operation of air conditioner.

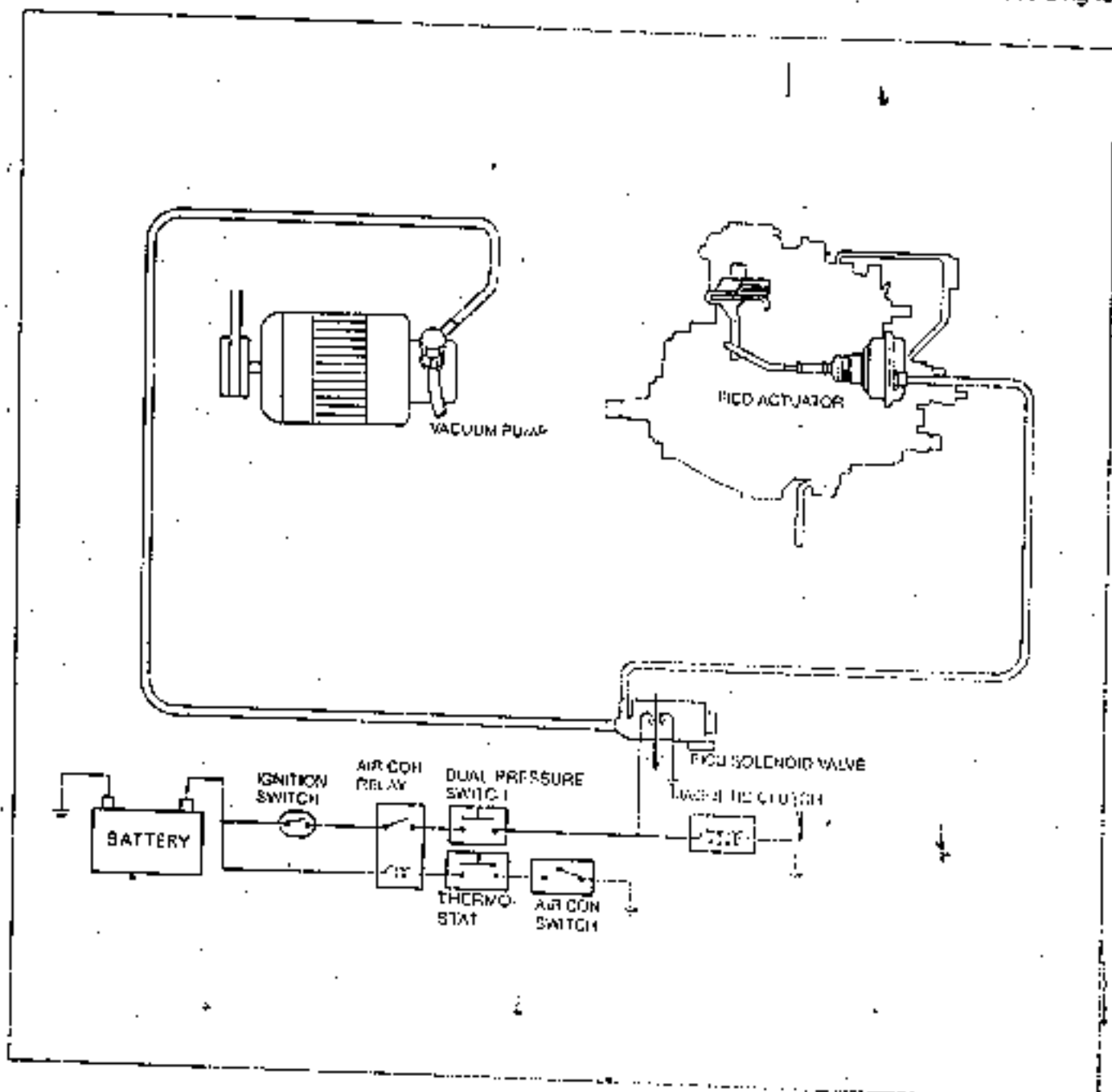

## 22A-14 FUEL SYSTEM FAST IDLE CONTROL DEVICE (FICD)

### INSPECTION

1. Warm up the engine upto the normal operating temperature (coolant temperature 60°C(140°F)).
2. After turning the air conditioner on (air con. switch ON and blower switch ON), check the idle speed.

Idle speed : 850-900 rpm

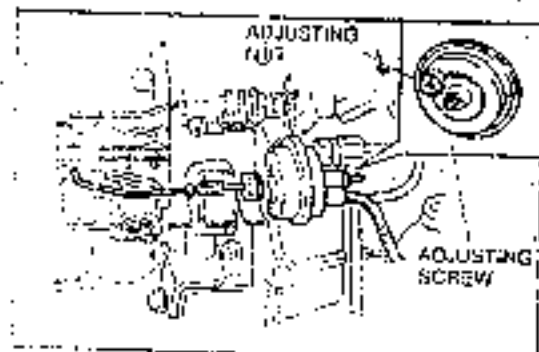

AN9022C32

### ADJUSTMENT

1. If idle speed is beyond the specification, loosen the actuator adjusting nut and adjust it by turning adjusting screw.

#### Note

Counterclockwise : Engine speed increases  
Clockwise : Engine speed decreases

2. If adjustment is impossible, loosen the actuator lock bolt and adjust engine speed again by moving the actuator body.

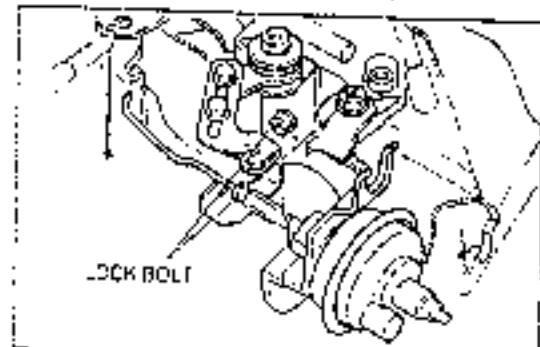

AN9015004

### FICD SOLENOID VALVE

#### Inspection

1. After turning the air conditioner on, check if air flows from hose ④ to ⑤.
2. After turning the air conditioner off, check if air does not flow from hose ④ to ⑤.

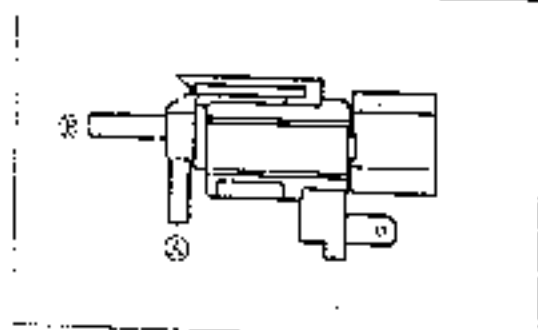

AL 4029034

## SPECIFICATION

Items		Specification
Fuel tank	Capacity l (qt)	65 ± 1 (68.7 ± 1.06)
Injection pump	Type	Distribution type (VE)
	Injection timing	ATDC 7° (Cam lift 1 min)
	Cam lift mm(in)	2.6(1.02)
	Rotating direction	Counterclockwise
	Governor type	Full all speed
	Driving method	Gear type
Idle speed	rpm	700-750
Idle up speed	rpm	850-900
Fuel filter (built-with sedimentor)		Cartridge type (with detector attached)
PCV device	Type	Closed
Fuel injection nozzle	Nozzle type	Throttle type
	Orifice diameter & number mm(in)	1.0 × 1 (0.04 × 1)
	Injection starting pressure kpa(kg/cm <sup>2</sup> , psi)	13230(135, 1918)

## SPECIAL TOOLS

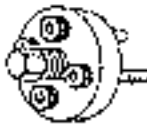
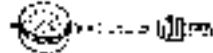
0K670 131 005 Extractor		For removing injection pump	0K670 131 010 Cam lift measuring device		For measuring cam lift
----------------------------	---	--------------------------------	---	---	---------------------------

# STARTING SYSTEM (J2 ENGINE)

31A

OUTLINE .....	31A- 3
QUICK START SYSTEM (QSS) .....	31A- 7
SPECIFICATION .....	31A-10
STARTER .....	31A- 4

OUTLINE

STRUCTURAL VIEW

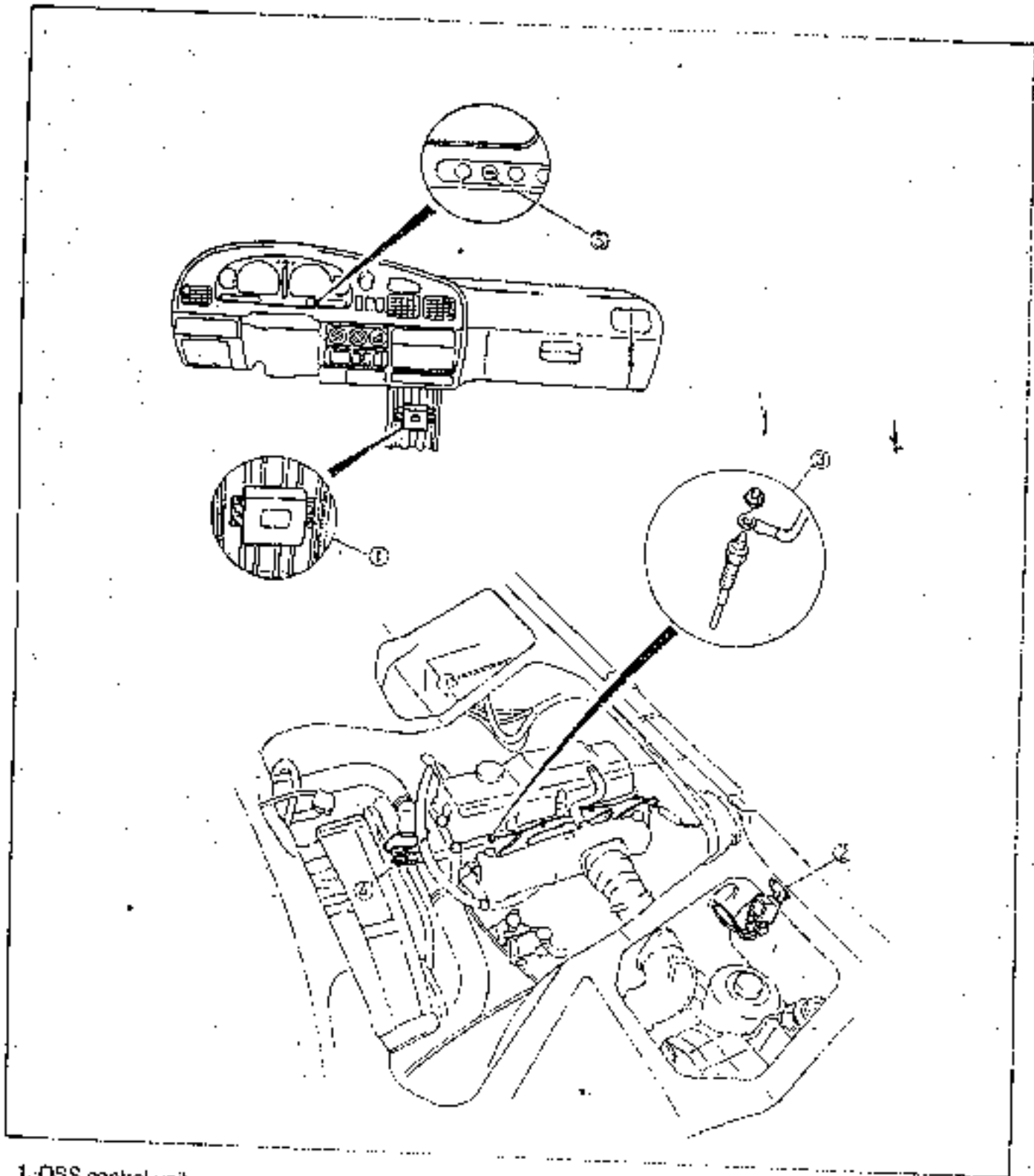

- 1. QSS control unit
- 2. Glow plug relay
- 3. Glow plug

- 4. Thermo switch
- 5. Glow indicator

# STARTER

## TROUBLESHOOTING GUIDE

Problem	Possible causes	Action
No engine cranking	Insufficient battery charging Loose, corroded or worn battery cable Malfunction of inhibitor switch (ATX only) Malfunction of fuse and wiring Malfunction of starter Malfunction of ignition switch	After checking specific Repair or Replace Adjust or Repair Repair or Replace Repair or Replace Repair or Replace
Starter rotates slowly	Insufficient battery charging Loose, corroded or worn battery cable Malfunction of starter	After checking specific Repair or Replace Repair or Replace
Starter rotates continuously	Malfunction of magnetic switch Malfunction of ignition switch Shorted wiring	Repair or Replace Repair or Replace Repair
Starter spins - No engine cranking	Worn pinion gear or starter malfunction Worn ring gear	Repair or Replace Replace

## ON-VEHICLE MAINTENANCE

### Pull-In Voltage

1. Inspect the battery voltage.

Voltage : above 12.4V

2. After starting the engine, check if the starter rotates smoothly.
3. If the starter does not rotate, check the "S" terminal voltage during cranking engine.

Voltage : above 8V

- Above 8V : inspect the starter.
- Below 8V : Inspect wiring (main fuse, ignition switch and inhibitor switch (ATX only)).

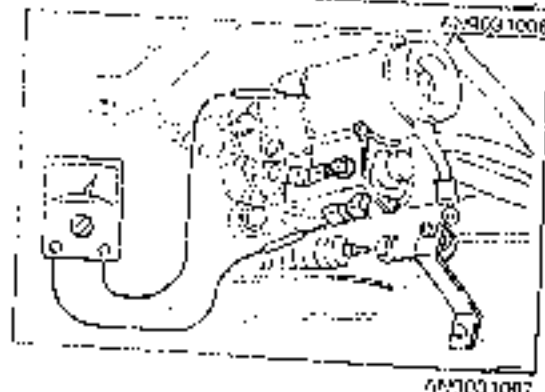
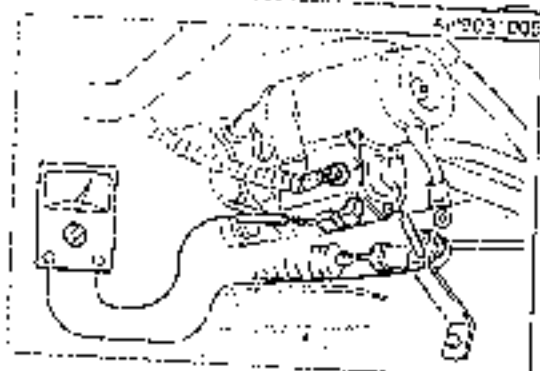
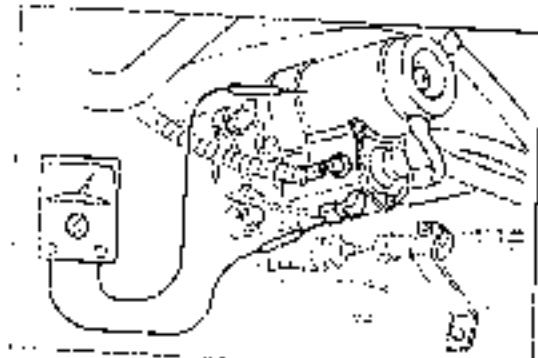

## MAGNETIC SWITCH

### Pull-In Coil

#### Note

- Remove the battery negative cable.
- Remove the "M" terminal of starting motor.

1. Do the continuity test between "S" and "M" terminal.
2. If it is opened, replace the magnetic switch.

### Hold-In Coil

1. Do the continuity test between "S" and switch body.
2. If it is opened, replace the magnetic switch.

## WIRING DIAGRAM

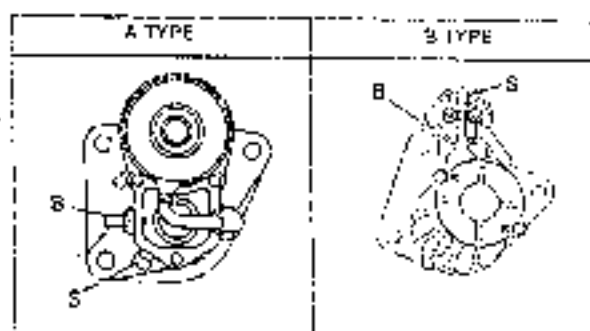
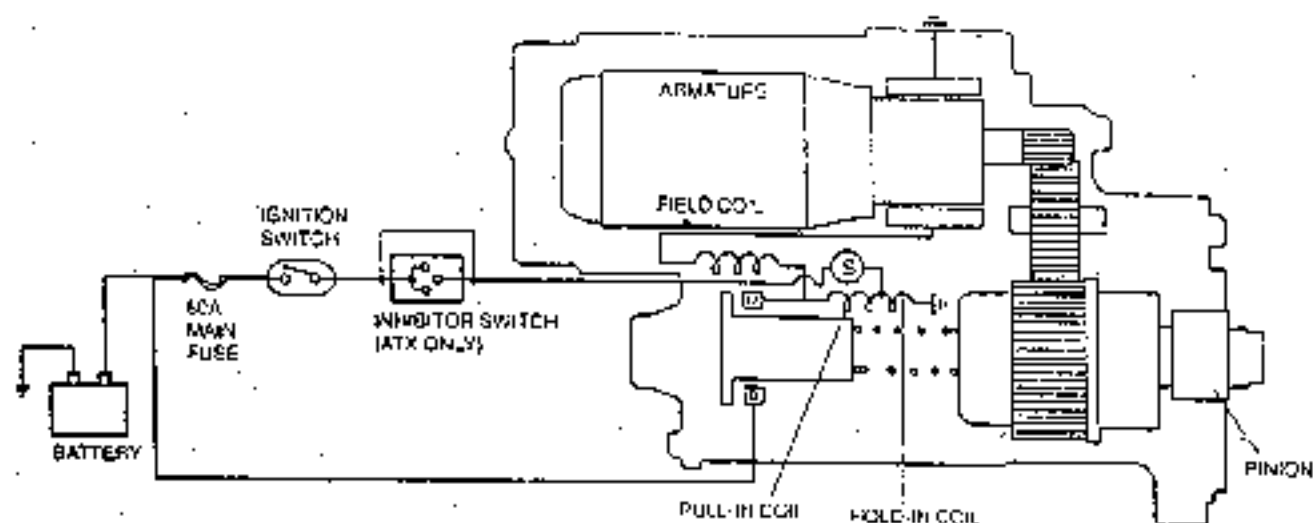

## INSPECTION

## Clutch and Gear

1. Check the condition of the pinion gear, idle gear and clutch assembly, and replace if it is damaged.

## Note

- If any damage is found, check the ring gear in fly-wheel side for wear or damage.

2. Check the rotating condition of the pinion gear, and replace the clutch assembly if necessary.

## Note

- Clockwise : fixed
- Counterclockwise : rotate

## No-Load Test

1. Connect the battery and ammeter to the starter as shown in the figure.
2. When the pinion is projected, check if the starter is rotated smoothly and finely.
3. Verify the specified current with the ammeter.

Current : Maximum 130A (at 11.0V)

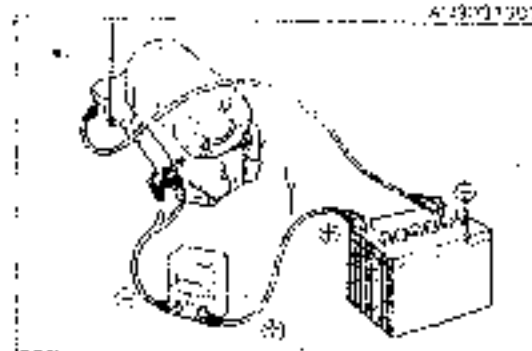

31-9131002

31-9131002

31-9131002

REMOVAL / INSTALLATION

1. Remove the battery negative cable.
2. Remove in the steps as shown in the figure.
3. Install in the reverse order of removal.

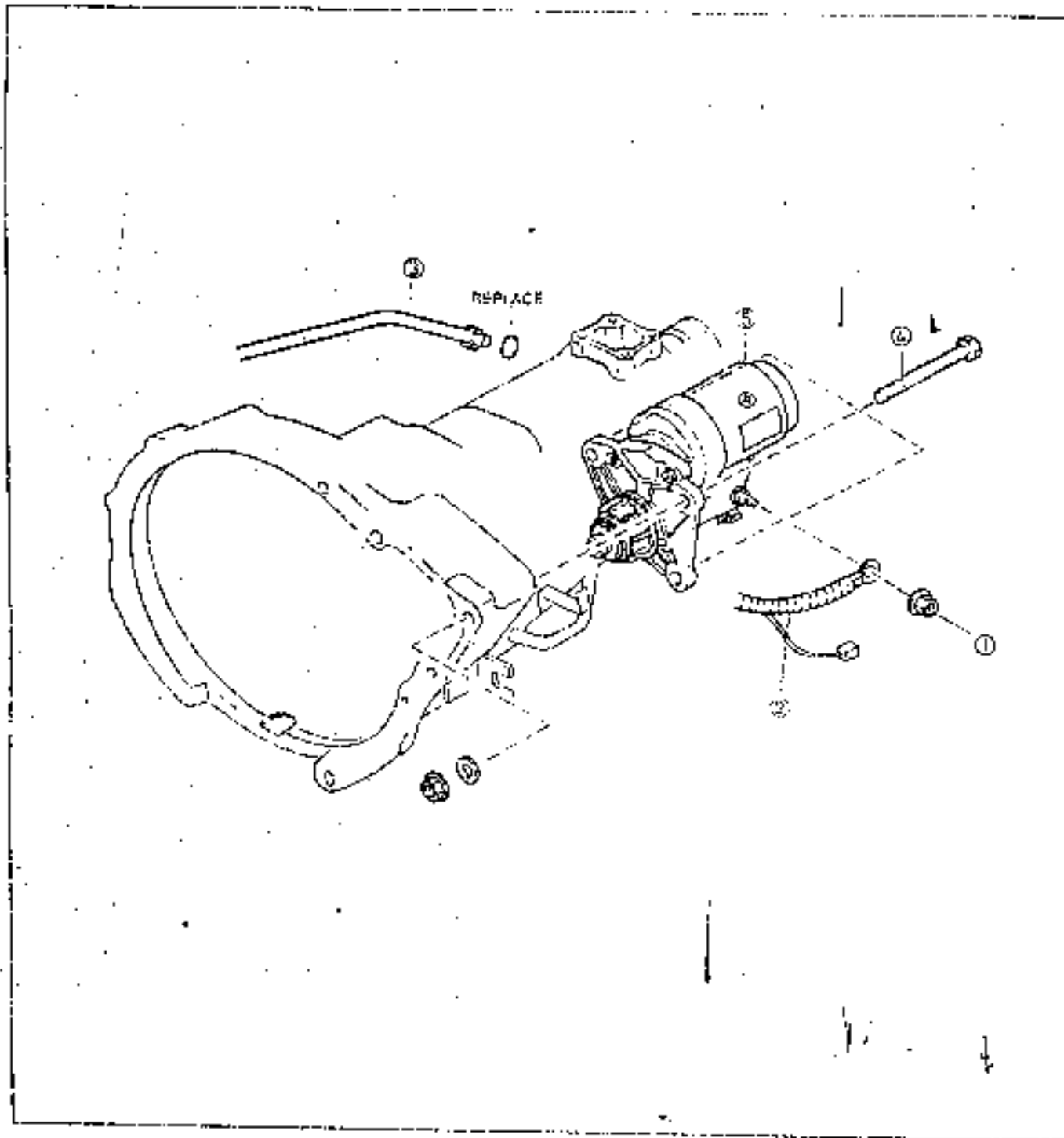

1. Nut
2. Connector ("S" and "B" terminal)
3. Filter gauge

4. Bolt
5. Starter



# QUICK START SYSTEM (QSS)

## TROUBLESHOOTING GUIDE

Problem	Possible causes	Action
Glow plug relay does not close	Malfunction glow plug relay Malfunction control unit internal circuit Poor connection or open circuit between control unit No. 2 terminal and wiring Open or short circuit of starter (open circuit .Repair at control unit No. 7 terminal) Poor connection or open circuit between glow plug relay terminal and wiring Malfunction glow plug	Replace Replace Repair Repair Repair Replace
Glow plug relay does not open	Malfunction glow plug relay Failure of control unit internal circuit	Replace Replace
Glow plug relay does not turns on and off	Poor connection for ignition switch Poor connection or open circuit of wiring for starter Failure of control unit internal circuit	Repair or Replace Repair Replace
Glow plug relay does not turns on and off for 15 seconds after turning Ignition switch on	Failure of water thermo switch Failure of control unit internal circuit Failure of glow plug relay Poor connection or open circuit between control unit No. 8 terminal and water thermo switch	Replace Replace Replace Repair

### Circuit Diagram

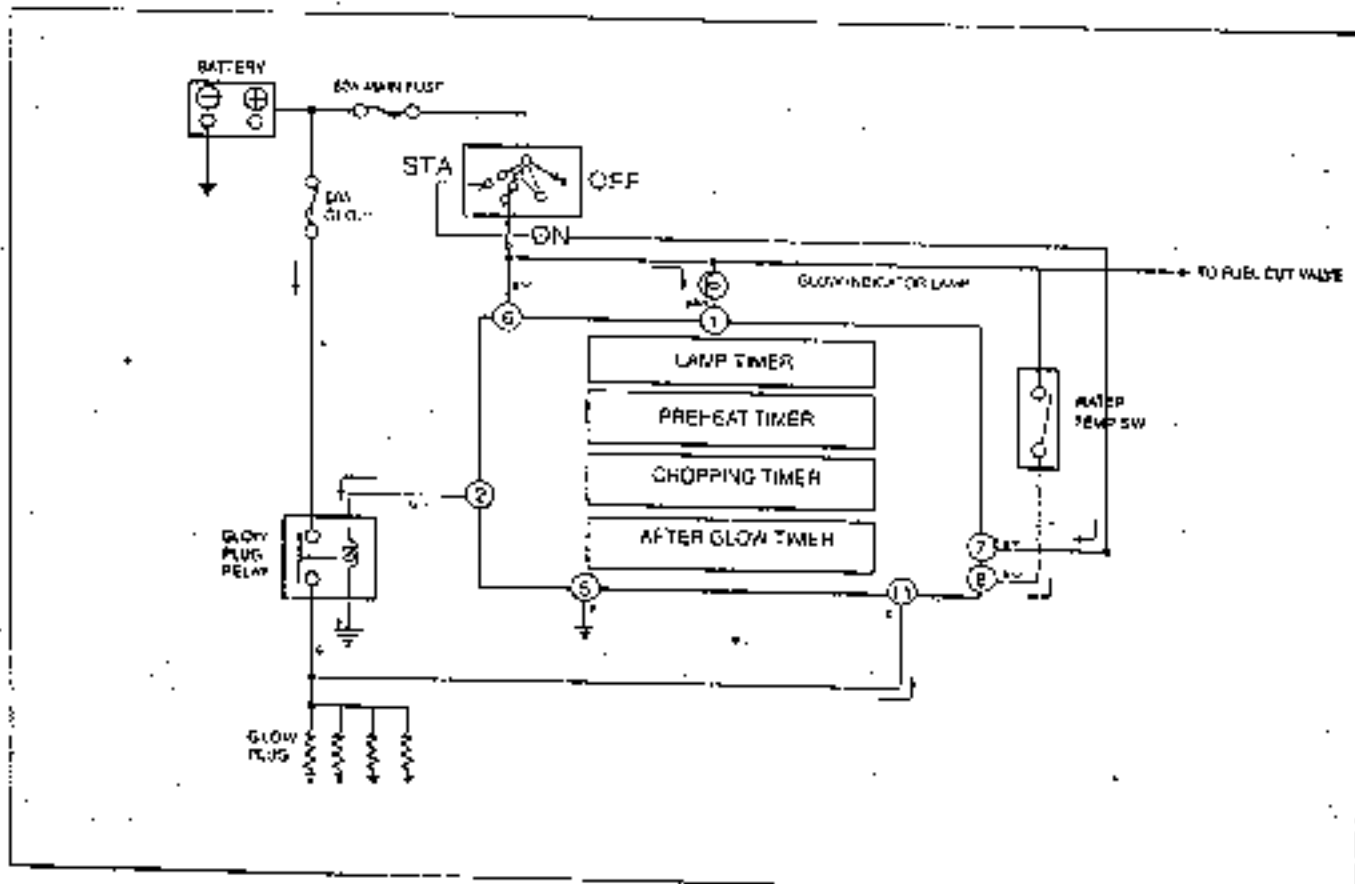

## OPERATING PATTERNS

1. Preheat timer
  - Operating condition ; ignition switch ON
  - Turns the glow relay on for 6-7 seconds in order to heat the glow plug quickly
2. Chopping timer
  - Operating condition ; ignition switch ON
  - Keeps the heating temperature of glow plug through the preheat timer by turning the glow relay on and off.
  - Operating condition ; ignition switch ON — STA
  - Keeps the heating temperature of glow plug through the preheat timer while ignition switch is in STA position.
3. After glow timer
  - Operating condition ; ignition switch ON → STA → ON (when water temperature is below 30°C(56°F).
  - Turns the glow relay on and off for about 15 seconds in order to improve idle stability after starting and reduce white smoke when engine is cold

### Note

- Turning the glow relay on and off can be verified by operation noise.

4. Lamp timer
  - Turns the glow indicator lamp on for about 5 seconds when ignition switch is in ON position.

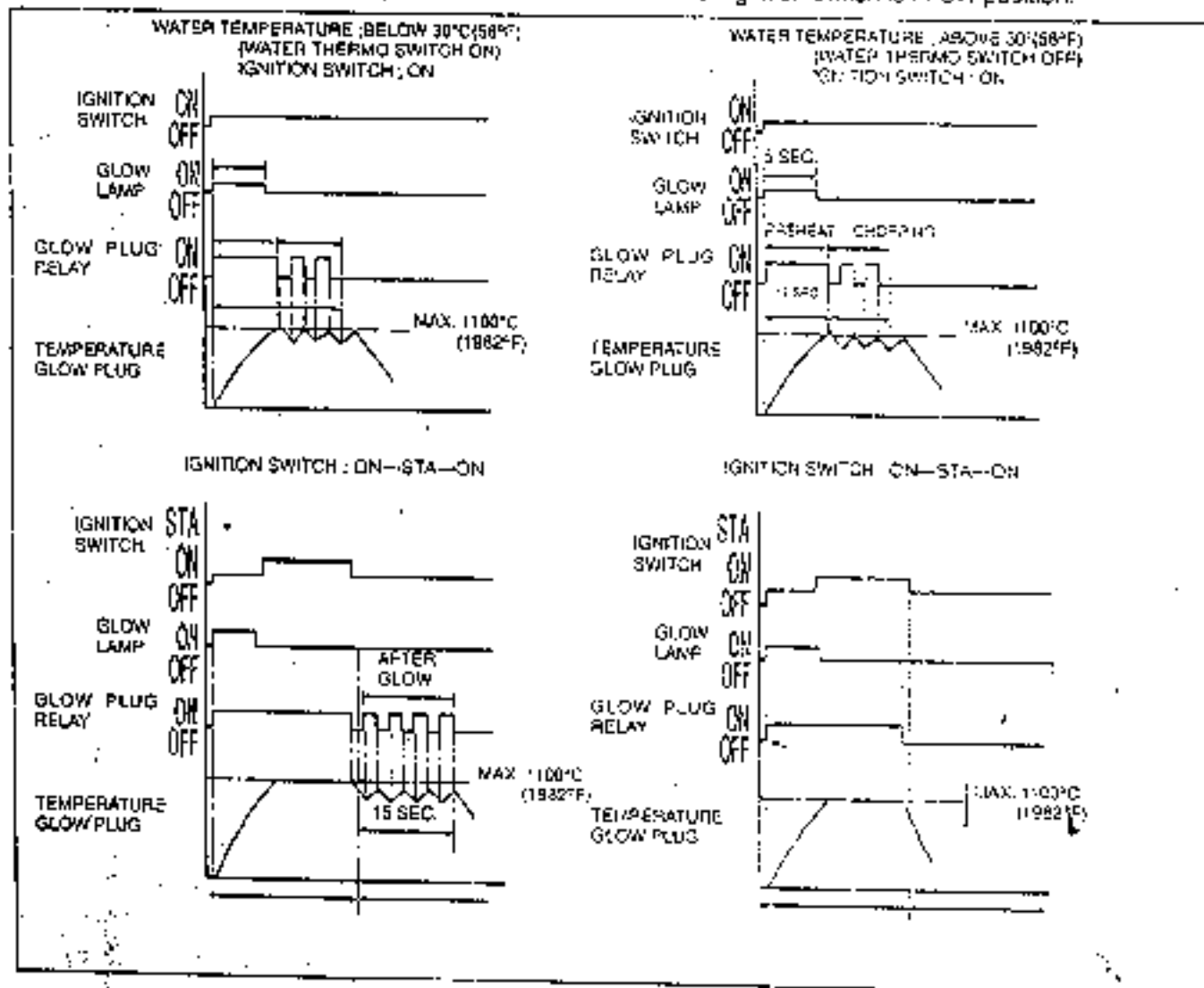

**CONTROL UNIT**

**Inspection**

1. Connect a voltmeter to the control unit as shown in the figure.
2. Referring to the following specification, inspect each terminal voltage, and replace the control unit if necessary.

**Note**

- If each terminal voltage is beyond specification, inspect the control unit after checking the connection condition at all wiring.

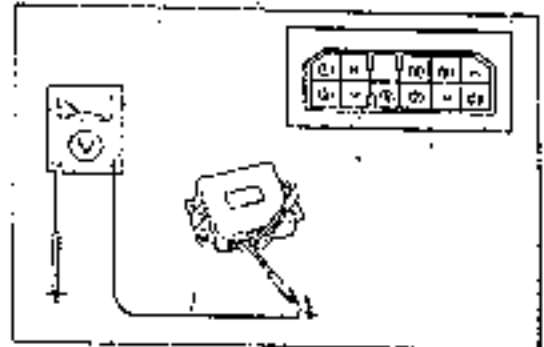

AI-8031011

**Terminal Voltages**

Terminal	Input	Output	Connected to	Operating Conditions	Voltage	Remarks
1		○	Glow plug lamp (In meter set)	Ignition switch ON For 5 sec After 5 sec	About 0V About 12V	
2		○	Glow plug relay	Ignition switch ON (without starting) For 7 sec After 7 sec	About 12V About 0-12V <small>(Glow relay, control relay)</small>	
5	—	—	Ground	—	About 0V	
6	○		Ignition switch (ON)	Ignition switch ON	About 12V	
7	○		Ignition switch (START)	Ignition switch START	About 12V	
8	○		Water thermo switch	Ignition switch ON (without starting)	About 12V About 0V	Water temp. : below 30°C Water temp. : above 30°C
11	○		Glow plug	Ignition switch START For 15 sec. after starting after 15 sec after starting	About 12V About 0-12V <small>(Glow relay, control relay)</small> About 0V About 0V	Water temp. : below 30°C (58°F) Water temp. : above 30°C

**GLOW PLUG RELAY**

**Inspection**

1. Measure the coil resistance (③~④ terminal) of the glow plug relay by ohmmeter.

Resistance : About 13Ω

2. Check if ①~② terminal is opened.
3. Apply the battery voltage to ③~④ terminal. Check if ①~② terminal is closed. If not, replace it.

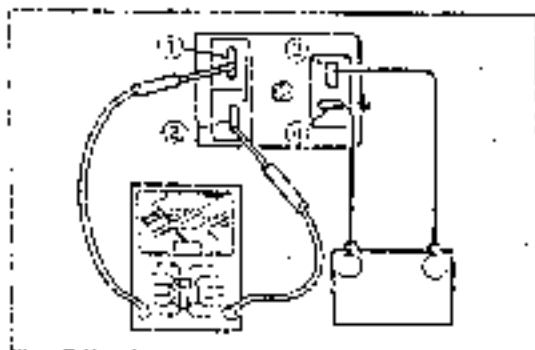

**GLOW PLUG**

**Inspection**

1. Do the continuity test with ohmmeter between the (+) terminal of glow plug and the cylinder head.
2. If it is opened, replace the glow plug.

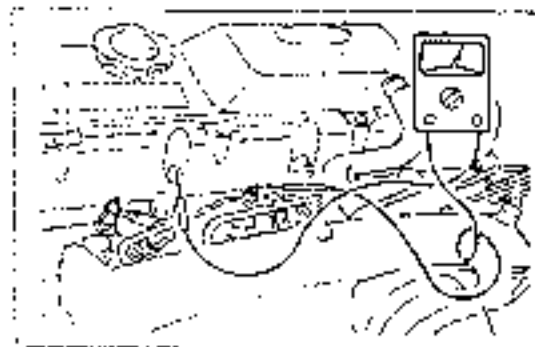

**REMOVAL / INSTALLATION**

Remove in the following steps.

1. Glow plug connector tightening nut
2. Glow plug connector
3. Glow plug

Install is in the reverse order of removal.

Tightening torque : 15~20 N·m(1.5~2.0 kg·m, 11~15 lb-ft)

**Note**

- Be sure to use the same type of glow plug. The assembling mark of glow plug is red.

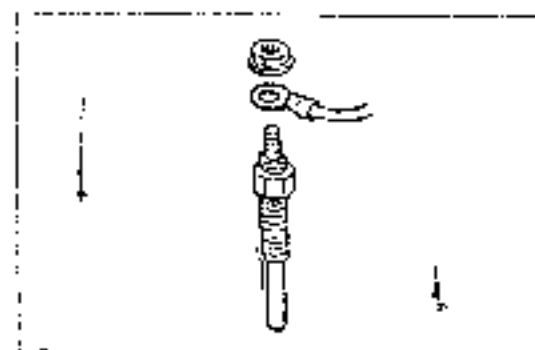

**WATER THERMO SWITCH**

**Inspection**

1. Check if the water thermo switch is closed at specified temperature, and replace if necessary.

Specified temperature : below 30°C(86°F)

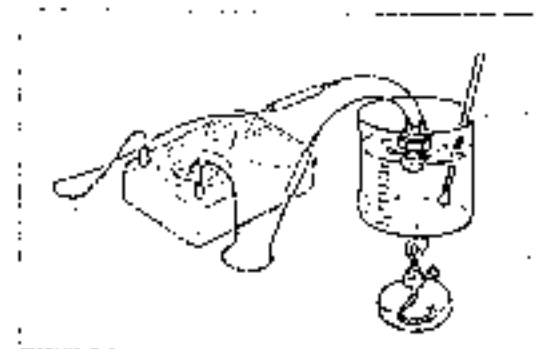

**SPECIFICATION**

Items		Specification
Starter	Type	Electro-Magneto engaged
	Voltage	12 V
	Output	2.2 Kw

# CHARGING SYSTEM (J2 ENGINE)

32A

ALTERNATOR .....	32A- 4
OUTLINE .....	32A- 3
REMOVAL / INSTALLATION .....	32A- 7
SPECIFICATION .....	32A- 8
TROUBLESHOOTING GUIDE .....	32A- 5

OUTLINE

STRUCTURAL VIEW

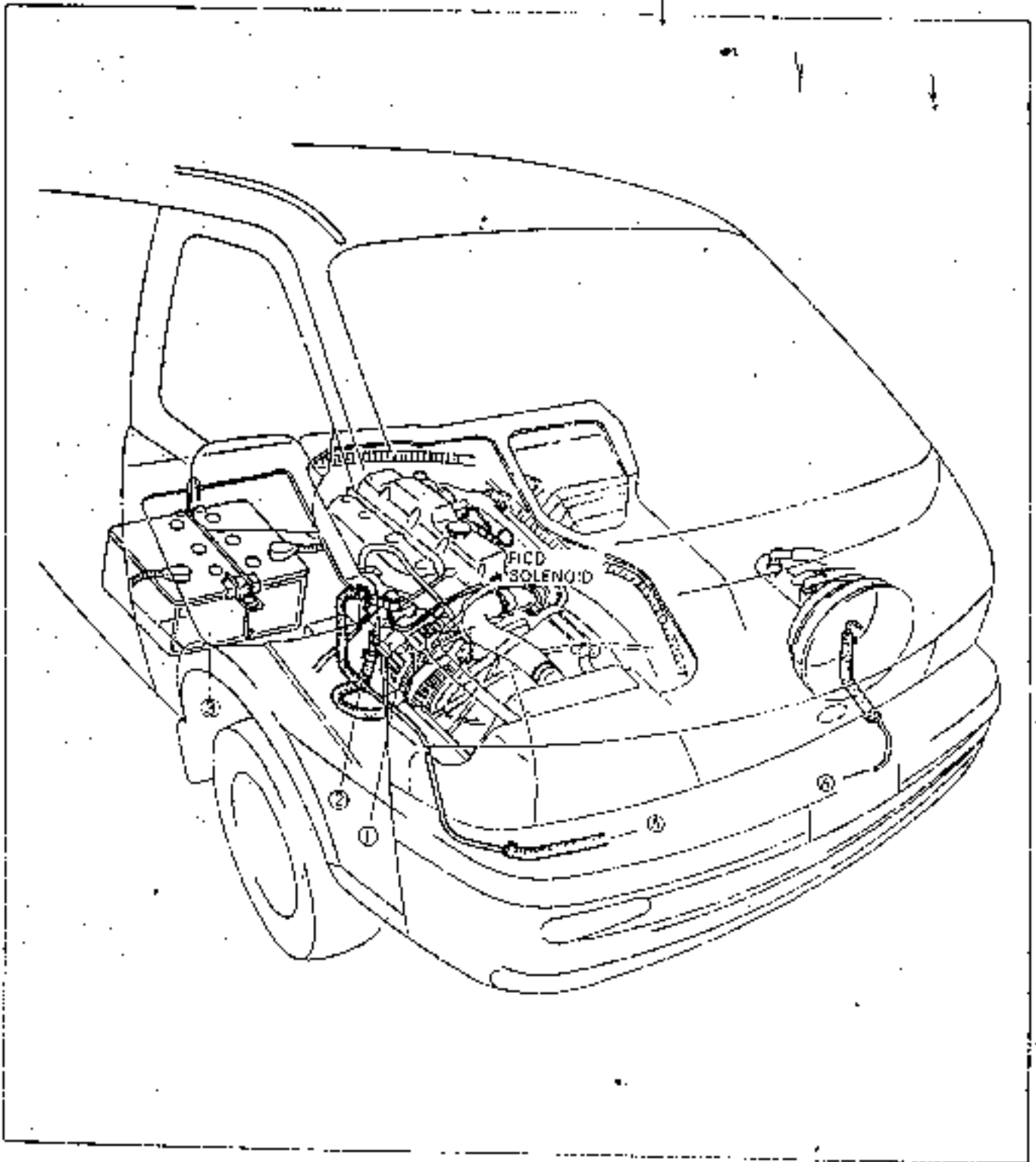

1. Alternator

2. Vacuum pump

3. Battery

AA9032001

## 32A-4 CHARGING SYSTEM ALTERNATOR

### ALTERNATOR

This is battery voltage sensing type to directly sense the charging voltage from battery, and keeps the best charging condition by controlling the alternator output voltage.

#### Circuit Diagram

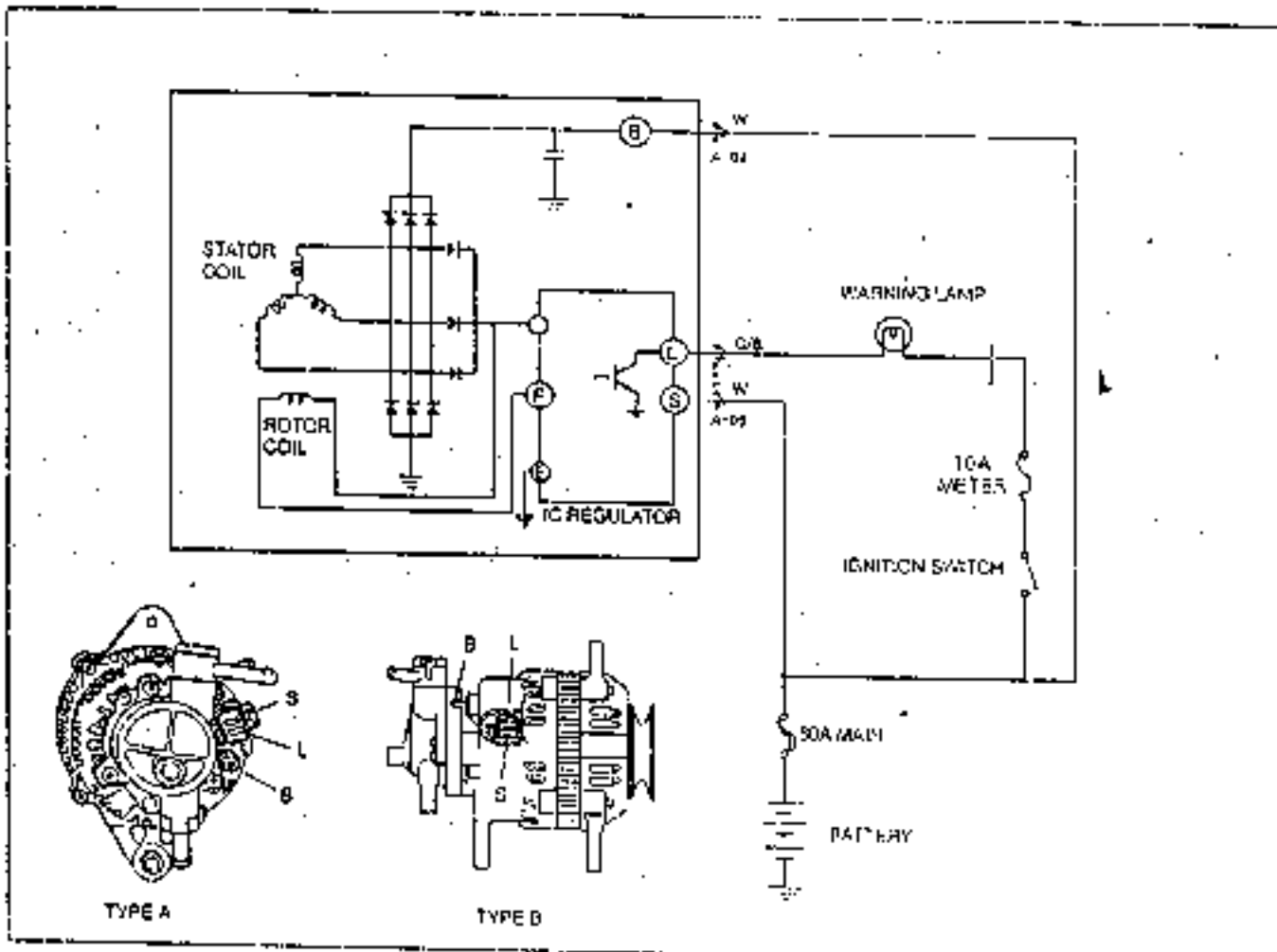

AN5032002

### ON-VEHICLE MAINTENANCE

#### Drive Belt

1. Check visually the belt for wear, crack or loose, and replace if necessary.
2. Apply moderate pressure (10 kg, 98 N) to the center portion of belt and check the tension, and adjust if necessary.

#### Deflection (Alternator drive belt)

mm(μ)

Belt Type	New	Used
Alternator	8-10(0.31~0.39)	10-12(0.39~0.47)

#### Note

- New one means a belt driven for below 5 minutes.
- Inspection for deflection should be done when engine is cold or at 30 minutes after engine is stopped.

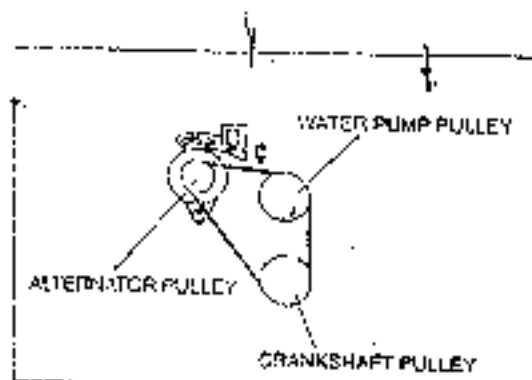

AN5032003

TROUBLESHOOTING GUIDE

ALTERNATOR

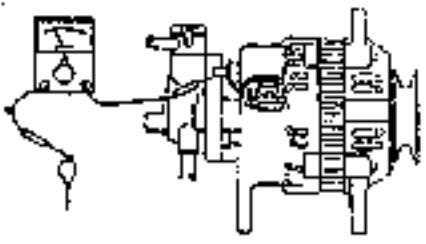
Step	Inspection	Actions													
1	Measure the battery voltage Standard ; Above 12.4V	Yes	Go to next step												
		No	Check the battery. (refer to page 32-6)												
2	After starting engine, check if the warning lamp turns off.	Yes	Inspect step 4												
		No	Go to next step												
3	Check if the alternator terminal <table border="1" data-bbox="284 588 836 735"> <thead> <tr> <th>Terminal</th> <th>Ig switch ON</th> <th>Idle(V)</th> </tr> </thead> <tbody> <tr> <td>B</td> <td>about 12V</td> <td>14.1-14.7</td> </tr> <tr> <td>L</td> <td>about 1V</td> <td>14.1-14.7</td> </tr> <tr> <td>S</td> <td>about 12V</td> <td>14.1-14.7</td> </tr> </tbody> </table>  <p style="text-align: center;">AN0032002-1</p>	Terminal	Ig switch ON	Idle(V)	B	about 12V	14.1-14.7	L	about 1V	14.1-14.7	S	about 12V	14.1-14.7	Yes	Inspect the bulb of warning lamp. Check the wiring between L terminal and the warning lamp.
		Terminal	Ig switch ON	Idle(V)											
B	about 12V	14.1-14.7													
L	about 1V	14.1-14.7													
S	about 12V	14.1-14.7													
No	Replace the alternator if no problem is found in wiring.														
4	1. Connect a ammeter (min.100A) between B terminal and wiring 2. Turn off all electric load after starting engine 3. Keep the engine speed to 2500-3000rpm. 4. Check if the output current increases when turning electric load on.	Yes	Charging system is normal												
		No	Go to next step.												
Caution Do not connect B terminal to ground.															
 <p style="text-align: center;">AN0032003</p>															
5	Check if the deflection of drive belt is normal	Yes	Replace the alternator												
		No	Adjust or replace the drive belt.												



**Vacuum Pump**

- 1. Connect a tachometer to the alternator pulley.
- 2. Connect a vacuum gauge to the vacuum hose which is connected to the vacuum pump and the power brake unit, and then inspect the specification.

Alternator : 1500rpm (engine 750rpm)  
 after 20 seconds : above 58 kpa(440mmHg, 17.3 inHg)  
 Alternator : 3000rpm (engine 1500rpm)  
 after 20 seconds : above 77 kpa(580mmHg, 22.8 inHg)



AN9032004

**BATTERY**

**Connection**

1. Check all terminals for looseness.
2. Check if the battery cable is corroded or damaged.
3. Inspect the rubber protector for proper coverage.
4. Clean terminals and coat them with grease after tightening

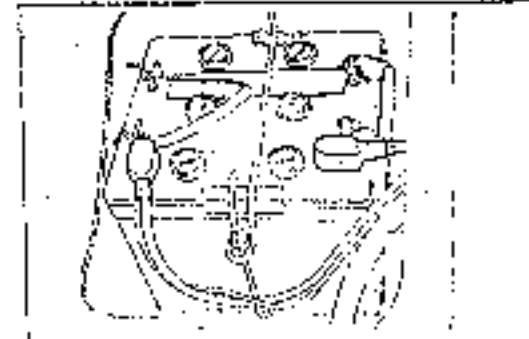

AN9032006

**Electrolyte Level**

1. Check if the electrolyte level is between the upper and lower level.
2. Add distilled water upto the upper level if it is insufficient.

**Caution**

- Do not overfill distilled water.

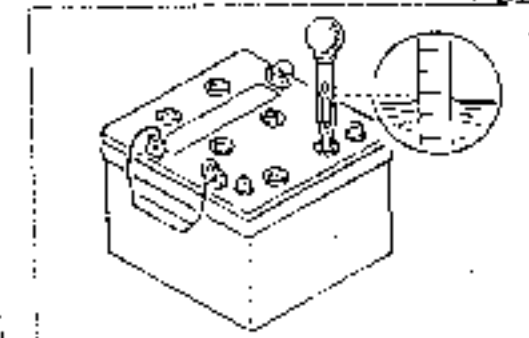

AN9032007

**Specific Gravity**

- 1. Measure the specific gravity of electrolyte by using a hydrometer.

Standard: 1.280 (at 25°C, 77°F)

2. If the specific gravity is below standard, charge the battery

**CHARGING**

Battery	Normal charging (A)	Quick charging (A)
PT00-26HL	7-8A	40

1. Charge the battery, referring to a table of temperature vs. specific gravity.

**Quick charging**

Remove the battery from vehicle and do quick charging after removing the vent plugs.

**Caution**

- Before inspecting or charging battery, turn all electric loads off and stop engine.
- Remove the negative terminal at first when removing, but connect the positive terminal at first, then the negative terminal later when installing.
- During quick charging, put the battery in a container filled with water to protect the battery from overheating.

**Normal charging**

1. Stop engine.
2. Turn all electric loads off
3. After removing the negative terminal, do normal charging (7~8A).

**Note**

- Add distilled water if charging is necessary.
- If the specific gravity is below standard, do normal charging.

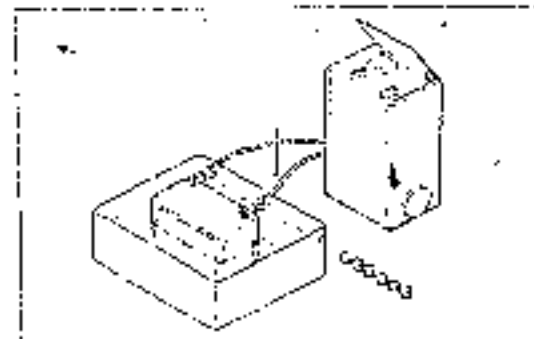

AN9032009

## REMOVAL / INSTALLATION

1. Remove in the steps shown in the figure (Refer to Section 10 for removal of the service cover).
2. Install in the reverse order of removal.

## Caution

- Do not connect the battery in reverse.
- Do not use a high voltmeter.
- Pay attention to the B terminal of alternator since the battery voltage is always applied to it.
- Do not connect the L terminal to ground while the engine is running.
- Do not start the engine when removing the L and S terminal connector.

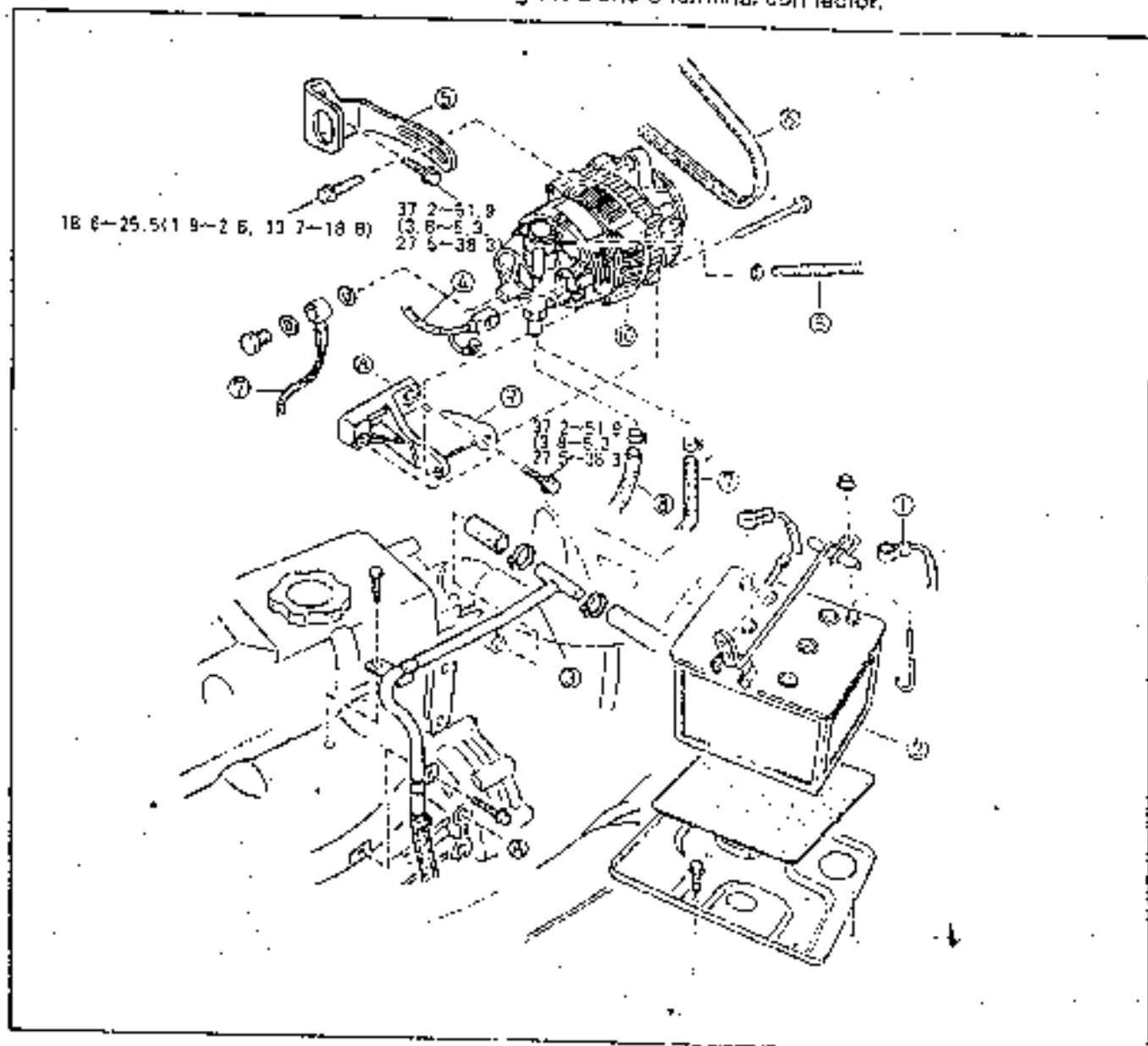

1. Battery negative terminal
2. Battery
3. Heater pipe assembly
4. Connector (L, S and B terminal)

5. Alternator strap
6. Drive belt
7. Oil hose

8. Vacuum hose
9. Alternator bracket
10. Alternator

A19031005

# 82A-8 CHARGING SYSTEM SPECIFICATION

## SPECIFICATION

Items		Specification			
Battery	Voltage	12V			
	Type and Capacity (5Hz)	RT60-284L (50)			
Alternator	Type	AC			
	Output	12.75			
	Regulator type	Transistor (Built with IC Regulator)			
	Drive belt tension mm(lb)	<table border="1"> <tr> <td>New one</td> <td>5-10(0.31-0.55)</td> </tr> <tr> <td>Used one</td> <td>10-12(0.39-0.47)</td> </tr> </table>	New one	5-10(0.31-0.55)	Used one
New one	5-10(0.31-0.55)				
Used one	10-12(0.39-0.47)				

# CLUTCH

40

CLUTCH AND FLYWHEEL .....	40- 9
CLUTCH PEDAL .....	40- 6
MASTER CYLINDER .....	40- 7
ON-VEHICLE MAINTENANCE .....	40- 6
RELEASE CYLINDER .....	40- 8
SPECIAL TOOLS .....	40-12
SPECIFICATIONS .....	40-12
STRUCTURAL VIEW .....	40- 3
TROUBLESHOOTING GUIDE .....	40- 4

## STRUCTURAL VIEW

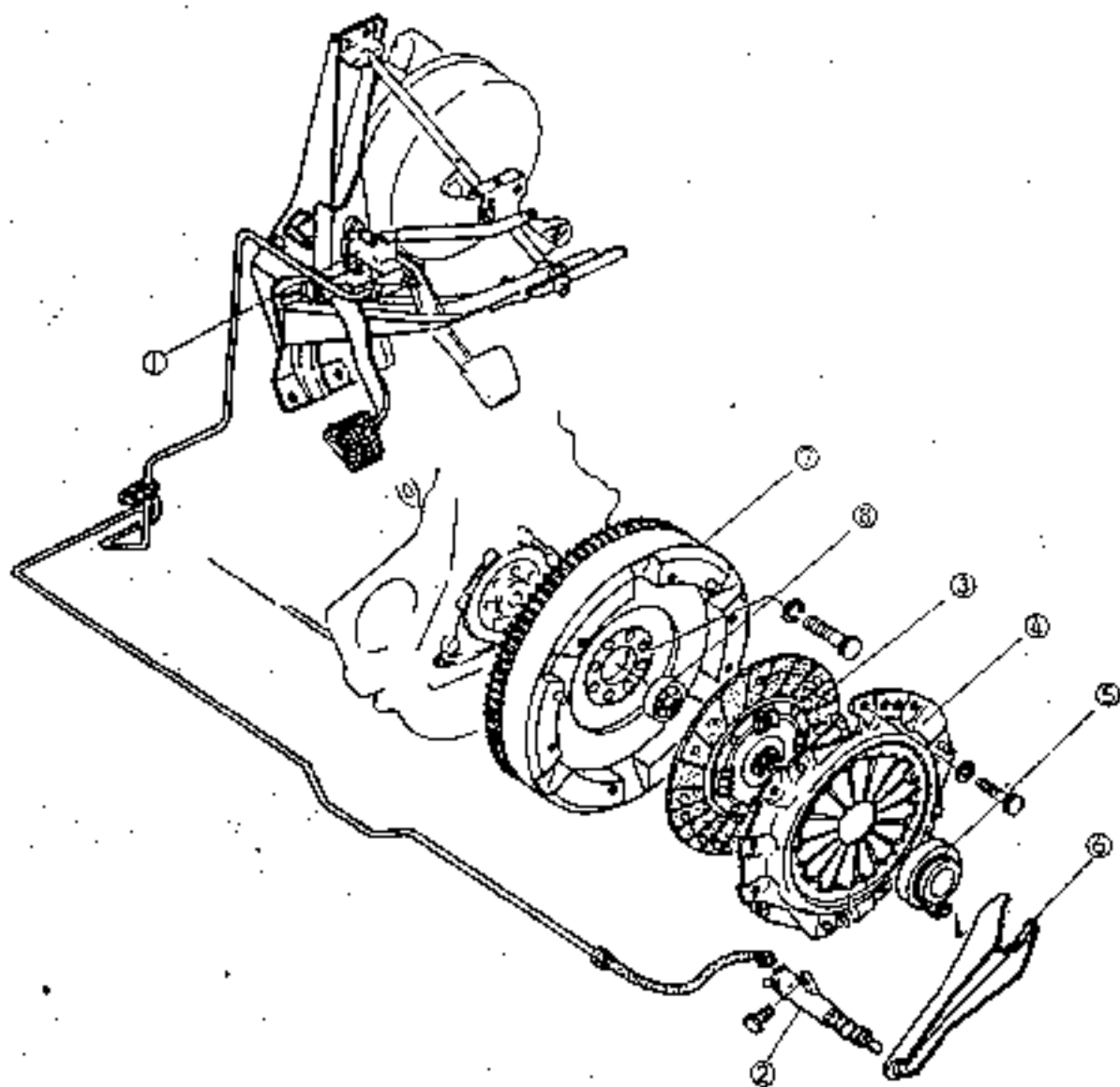

1. Clutch master cylinder
2. Clutch release cylinder
3. Clutch disk
4. Clutch cover

5. Clutch release bearing
6. Clutch release fork
7. Flywheel
8. Pilot bearing

# CLUTCH TROUBLESHOOTING GUIDE

## TROUBLESHOOTING GUIDE

	Possible causes	Action
Slippage	Excessively worn facing surface Hardened or oil contaminated facing surface Deformed clutch cover Damaged or fatigued diaphragm spring Excessive play of clutch pedal Stuck clutch pedal	Replace Repair or Replace Repair or Replace Replace Adjust Repair or Replace
Faulty or disengagement	Damaged clutch disk and excessive runout Worn and corroded clutch disk spline rust Oil contaminated clutch disk Fatigued diaphragm spring Misadjusted clutch pedal Insufficient clutch fluid Leakage of clutch fluid	Replace Replace or Remove Repair or Replace Replace Adjust Add Repair or Add
Vibrates/shaking	Oil contaminated facing surface Fatigued torsion spring Hardened or deformed facing surface Loose clutch disc rivet Excessively deflected clutch cover Hardened or damaged flywheel surface Loose engine mount or fatigued rubber	Clean or Replace Replace Repair or Replace Replace Replace Repair or Replace Repair or Replace
Clutch pedal sticking	Failure of lubrication of pedal shaft	Repair or Replace
Abnormal noise	Damaged release bearing Failure of lubrication of release bearing sleeve Worn sliding part of release fork Fatigued torsion spring Worn or damaged pilot bearing Excessive end play of crankshaft	Replace Lubricate or Replace Replace Replace Replace Adjust

## ON-VEHICLE MAINTENANCE

## Fluid Level

1. Clean the fluid container and cap.
2. Check the fluid level. If the fluid level is near or below "MIN" mark, add the specified fluid up to the "MAX" mark.

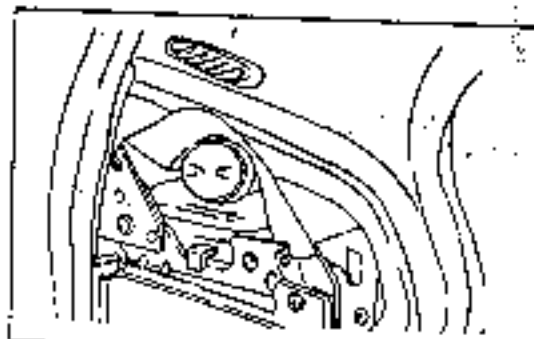

ANR040007

## INSPECTION AND ADJUSTMENT

## CLUTCH PEDAL HEIGHT

## Inspection

Measure the distance from the center of the upper surface of pedal pad to the floor.

Pedal height : 195~196 mm(7.68~7.72 in)

## Adjustment

1. Loosen the lock nut ④ and adjust the pedal height by turning the adjust bolt ③.
2. Tighten the lock nut ④ after adjusting.

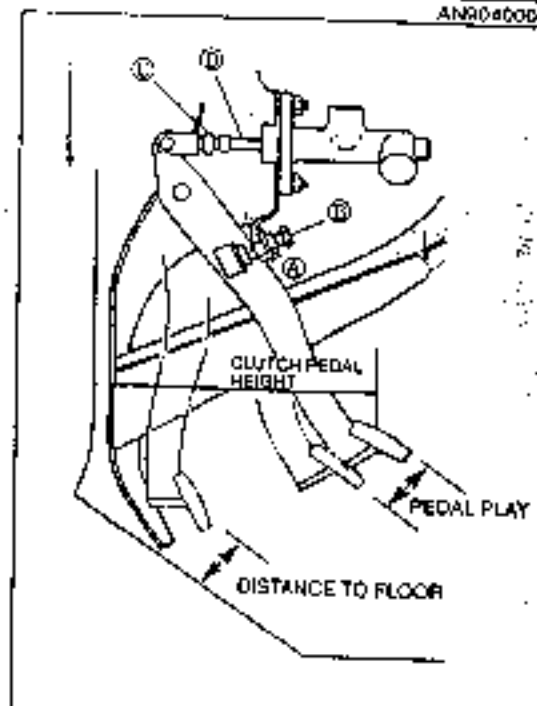

ANR040003

## PEDAL FREE PLAY

## INSPECTION

Push the pedal lightly by hand until you feel the hydraulic pressure.

Pedal free play : 0.6~3.0 mm(0.024~0.118 in)

## ADJUSTMENT

1. Loosen the lock nut ③ and adjust the pedal free play by turning the push rod ①.
2. Measure the distance from the pedal to the floor when the clutch pedal is fully depressed.

Distance to floor : 54 mm(2.13 in)

3. Tighten the lock nut.
4. Check the pedal height after adjusting.

**CLUTCH PEDAL**

**REMOVAL / INSTALLATION**

1. Remove in the steps shown in the figure.
2. Inspect all parts, and repair or replace if necessary.
3. Install in the reverse order of removal.
4. After installing, inspect and adjust the pedal height and free play if necessary.

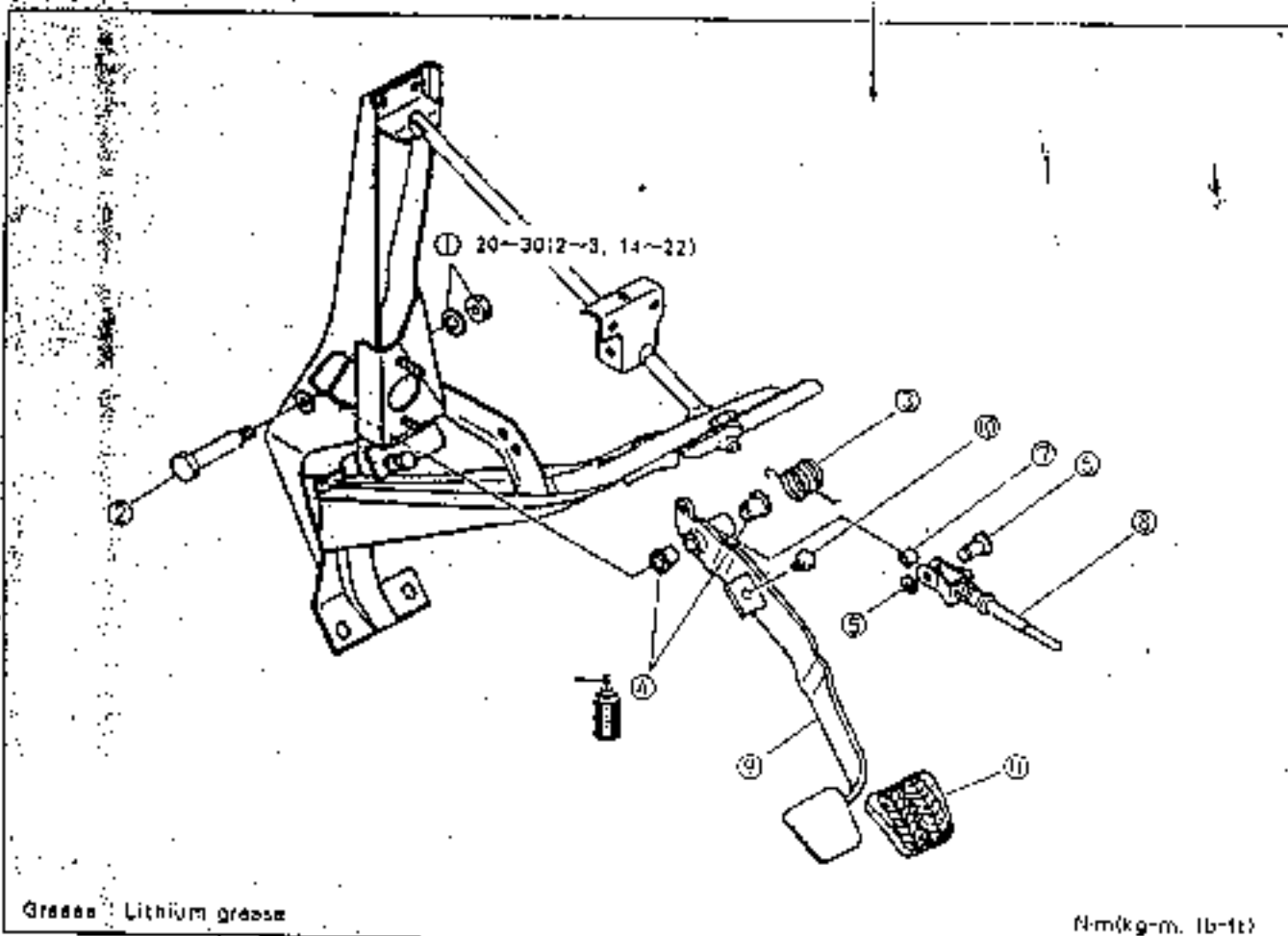

AN6040034

1. Nut and washer
2. Bolt
3. Return spring
4. Bushing

5. Clip
6. Pin
7. Spacer
8. Push rod

9. Clutch pedal
10. Stopper rubber
11. Pedal pad

**INSPECTION**

**Clutch Pedal**

1. Replace after inspecting wear of bushing, deflection of pedal and damage of return spring.

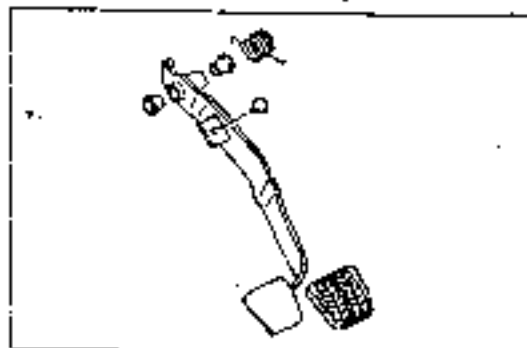

AN6040005



## MASTER CYLINDER

### REMOVAL / INSTALLATION

1. Remove in the steps shown in the figure.
2. Inspect all parts, and repair or replace if necessary.
3. Install in the reverse order of removal.

#### Caution

Drain the clutch fluid by using a container or clothes because it can give damage to painted surfaces. If the fluid is dropped on painted surfaces, clean it immediately.

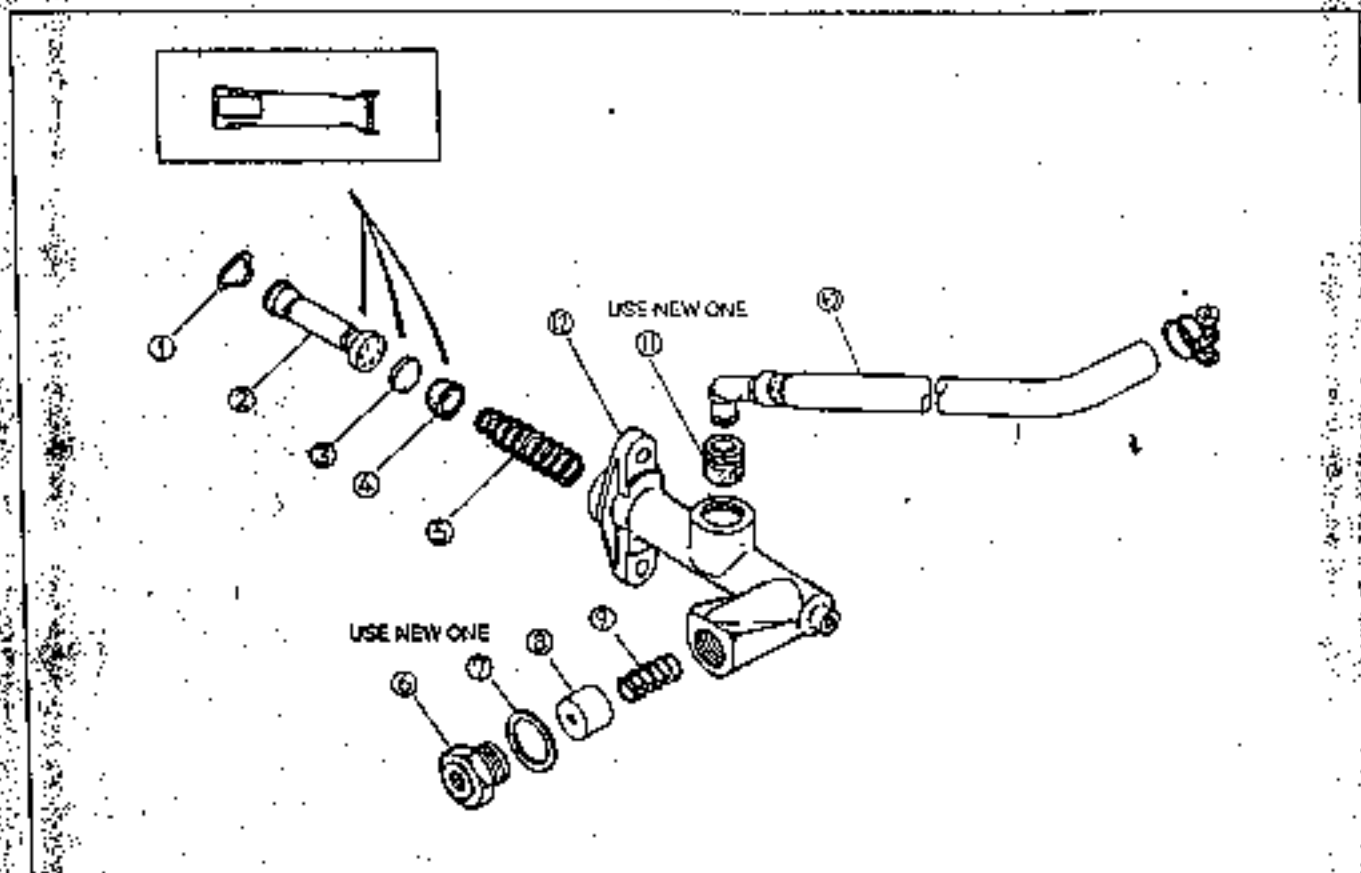

- |                                  |                   |                            |
|----------------------------------|-------------------|----------------------------|
| 1. Stop wire                     | 5. Return spring  | 9. Oneway valve spring     |
| 2. Piston and secondary assembly | 6. Plug           | 10. Reserve tank hose      |
| 3. Protector                     | 7. Sealing washer | 11. Bushing                |
| 4. Primary cup                   | 8. Oneway valve   | 12. Clutch master cylinder |

#### How to disassemble stop wire

Remove the stop wire by using a screwdriver while pushing it down.

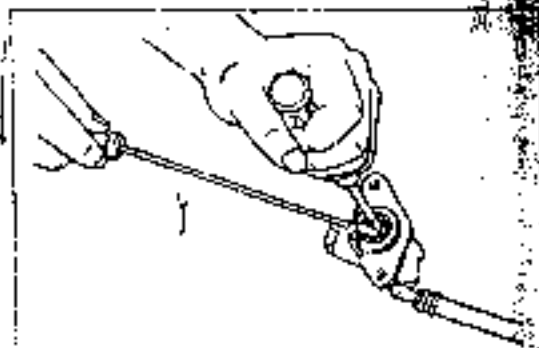

AN904002

## RELEASE CYLINDER

## REMOVAL / INSTALLATION

1. Remove in the steps shown in the figure.
2. Inspect all parts, and repair or replace if necessary.
3. Install in the reverse order of removal.

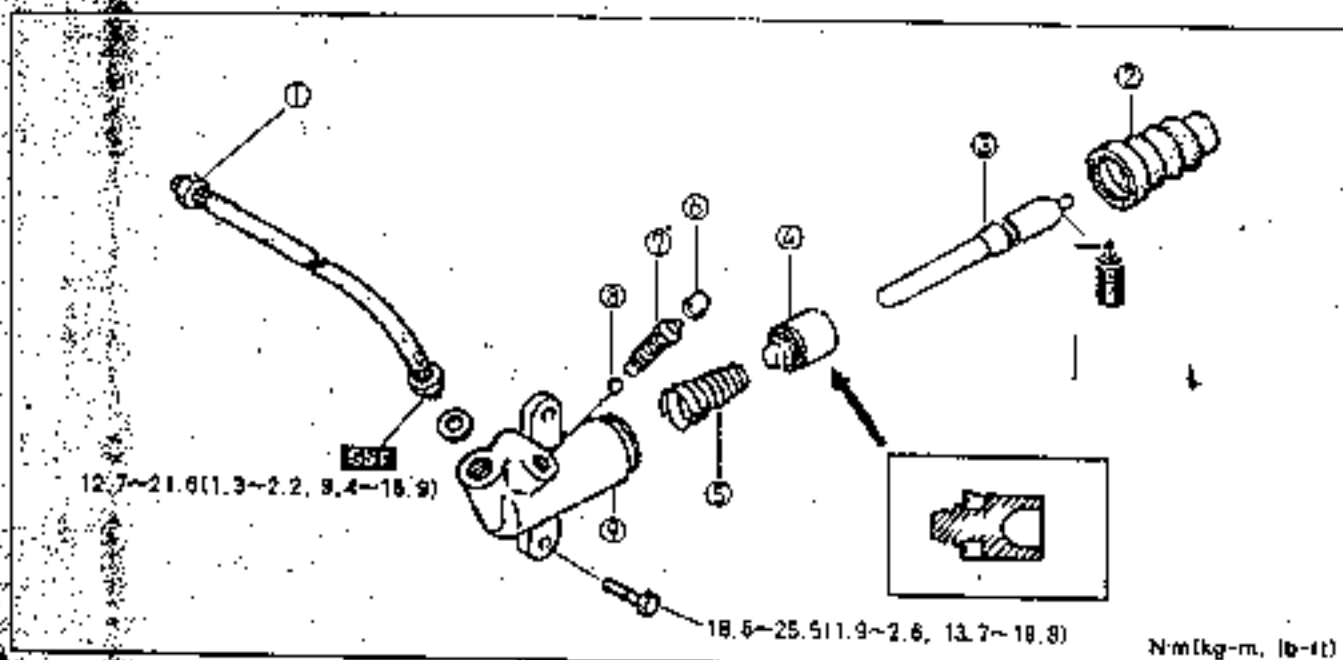

1. Flexible hose
2. Boot
3. Push rod

4. Piston and cup assembly
5. Return spring cylinder
6. Bleeder plug cap

7. Bleeder plug
8. Steel ball
9. Clutch release cylinder

AN804000B

## AIR BLEEDING

## Warning

Air which soaked into the clutch hydraulic device during removing pipe for repair, should be bled, after disassembling and assembling the clutch master cylinder.

## Note

During air bleeding, the fluid in the reserve tank should be kept to 2/3 level.  
Drain the clutch fluid by using a container or clothes because it can give damage to painted surfaces. If the fluid is dropped on painted surfaces, clean it immediately.

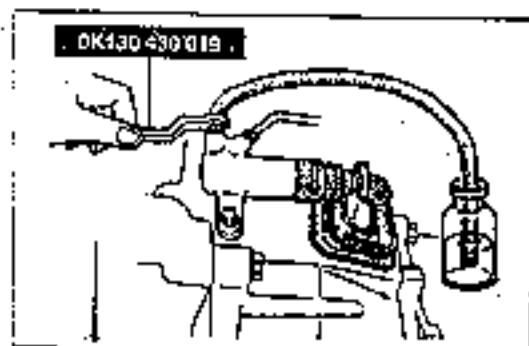

1. Remove the bleeder cap from the clutch release cylinder and insert a vinyl hose into the bleeder plug.
2. Put the opposite end of vinyl hose into a container.
3. Pump the clutch pedal slowly several times.
4. While depressing the clutch pedal, loosen the bleeder screw so that the fluid and air can be blown out.
5. Repeat step 3 and 4 until the air bubble in fluid is gone.

Tightening torque : 5.9~6.8 N·m(60~90 kg-cm, 52~78 lb-in)

6. Inspect the clutch pedal for correct operation.

## CLUTCH AND FLYWHEEL

## Caution

Apply grease to the spline part of the clutch disk assembly (or to the transmission propeller shaft) and before installing it to the engine flywheel, insert into the transmission propeller spline and remove, and then wipe out grease left which is generated at the side surface of clutch disk spline (transmission side, engine side) or the transmission propeller shaft.

## REMOVAL / INSTALLATION

1. Remove in the steps shown in the figure.
2. Install in the reverse order of removal.
3. Apply grease to any place needed.

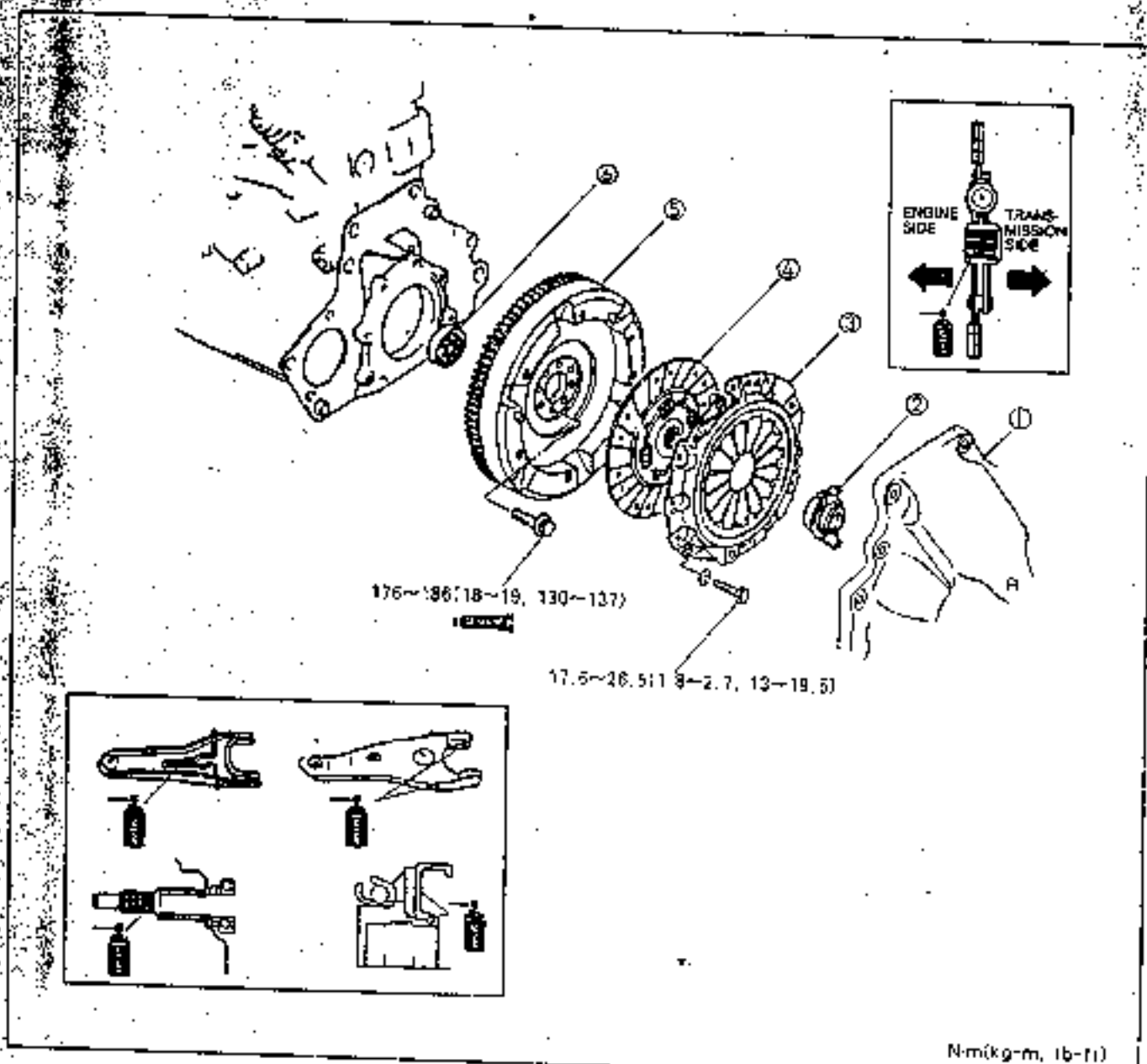

1. Transmission (Refer to section 42)
2. Release bearing
3. Clutch cover

4. Clutch disk
5. Flywheel
6. Bearing

AN00400 LD

**Release Bearing**

Do not clean the release bearing with solvent. Solvent will remove sealed-in lubricant and will cause bearing failure.

1. By pushing and turning the release collar to the thrust side, replace it, if it is not rotated smoothly or it is noisy.

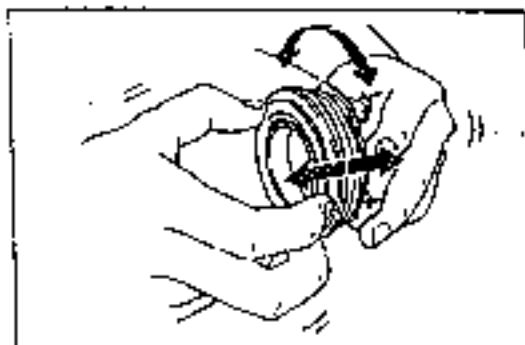

BSX040024

**Clutch Cover**

**Note**

Repair for minor rust or discoloration by using a sandpaper.

1. Inspect the facing surface with the clutch disc for rust, crack and fatigue.
2. Inspect the facing surface with the clutch release bearing for wear and crack.

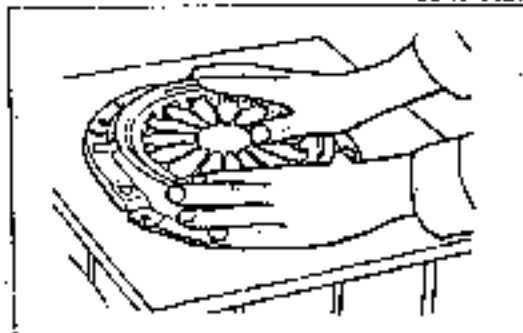

AN7040033

**Clutch Disc**

**Note**

Repair for minor failure by using a sandpaper.

1. Inspect for hardened lining surface and oil on the lining surface.
2. Inspect loose rivet.

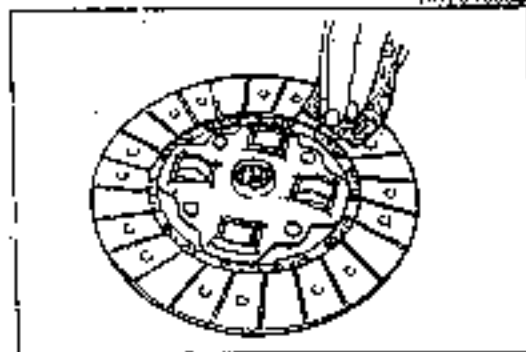

BSX140026

3. Measure the rivet head depth with a slide caliper. Replace worn disc.

Limit : 0.3 mm(0.012 in)

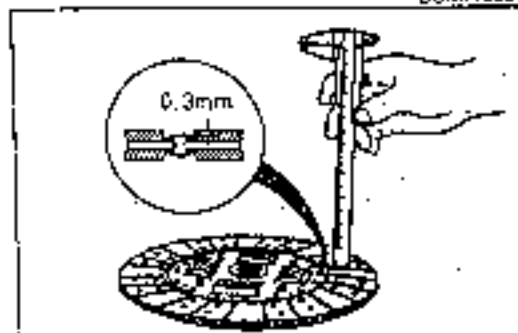

BSX040027

4. Measure runout of the clutch disc. Replace if it exceeds the limit.

Limit : 0.7 mm(0.028 in)

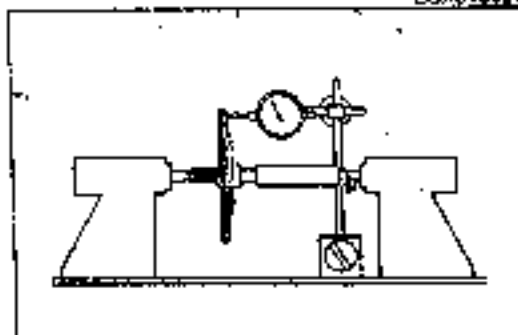

AN7040035

# CLUTCH CLUTCH AND FLYWHEEL

## Clutch Release Bearing

Do not clean the release bearing with solvent. Solvent will remove sealed-in lubricant and will cause bearing failure.

1. By pushing and turning the release collar to the thrust side, replace it, if it is not rotated smoothly or it is noisy.

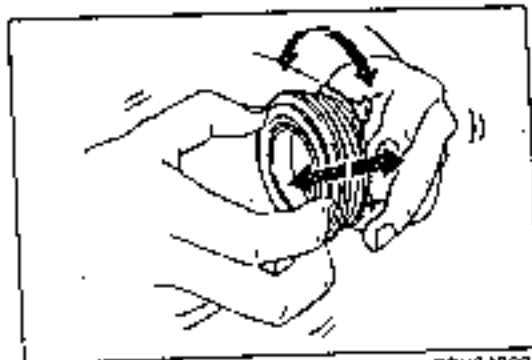

BSX040024

## Clutch Cover

### Note

Repair for minor rust or discoloration by using a sandpaper.

1. Inspect the facing surface with the clutch disc for rust, crack and fatigue.
2. Inspect the facing surface with the clutch release bearing for wear and crack.

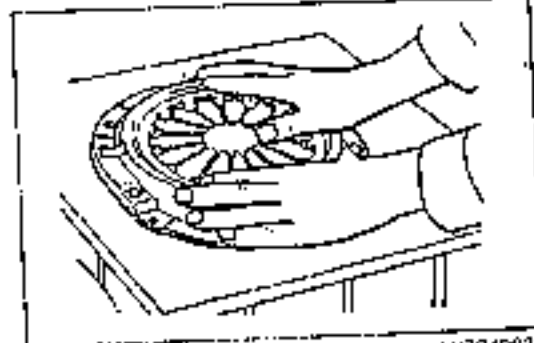

AN7040033

## Clutch Disc

### Note

Repair for minor failure by using a sandpaper.

1. Inspect for hardened lining surface and oil on the lining surface.
2. Inspect loose rivet.

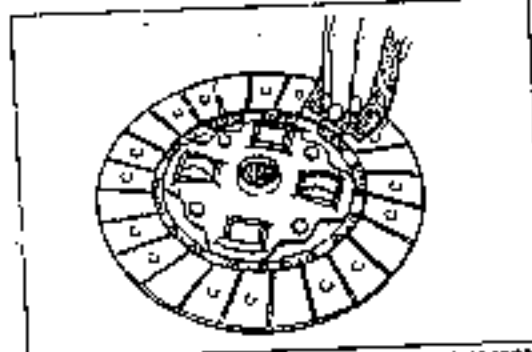

BSX040028

3. Measure the rivet head depth with a slide caliper. Replace worn disc.

Limit : 0.3 mm (0.012 in)

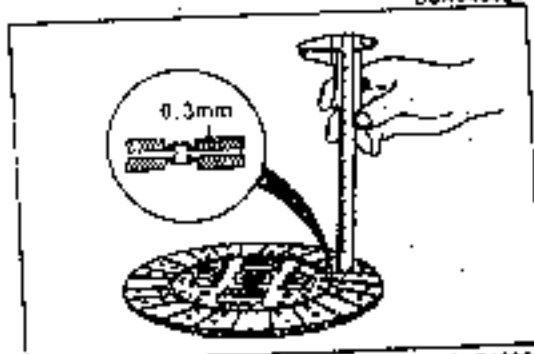

BSX040027

4. Measure runout of the clutch disc. Replace if it exceeds the limit.

Limit : 0.7 mm (0.028 in)

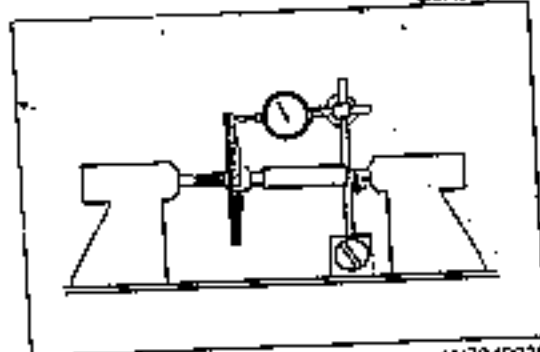



AN7040036

**SPECIFICATIONS**

Items		Specifications	
Clutch control		Hydraulic type	
Clutch cover	Type	Diaphragm spring	
	Pressure force	kg(N, lb) 530	
Clutch disc	Outer diameter	mm(in) 240(9.4)	
	Inner diameter	mm(in) 160(6.3)	
	Thickness	Pressure plate side	mm(in) 3.5(0.14)
		Flywheel side	mm(in) 3.5
Clutch pedal	Type	Suspended	
	Pedal ratio	6.3	
	Full stroke	mm(in) 155(6.1)	
	Height	mm(in) 195.5(7.7)	
Master cylinder	Inner diameter	mm(in) 15.8(0.63)	
Pilot cylinder	Inner diameter	mm(in) 19.1(0.75)	
Clutch fluid		FMVSS No.118, DOT-3	

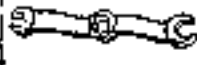
**SPECIAL TOOLS**

<p>OK130 180 010</p> <p>Clutch disc centering tool</p> 	<p>Clutch disc to center of flywheel</p>	<p>OK130 430 019</p> <p>Flare nut wrench</p> 	<p>Removing the clutch pipe</p>
<p>OK410 111 012</p> <p>Bearing puller</p> 	<p>Removing the pilot bearing</p>	<p>OK670 111 004</p> <p>Ring gear brake</p> 	<p>Protecting the flywheel from rotating</p>

# MANUAL TRANSMISSION

41

DISASSEMBLY/ASSEMBLY .....	41- 6
INSPECTION .....	41-12
OUTLINE .....	41- 3
REMOVAL/INSTALLATION .....	41- 5
SPECIAL TOOLS .....	41-15
SPECIFICATIONS .....	41-14
CHANGE CONTROL .....	41-13
TROUBLESHOOTING GUIDE .....	41- 4

**OUTLINE**

Control performance is improved by adapting the double synchronizer ring to the 1st and 2nd gear.

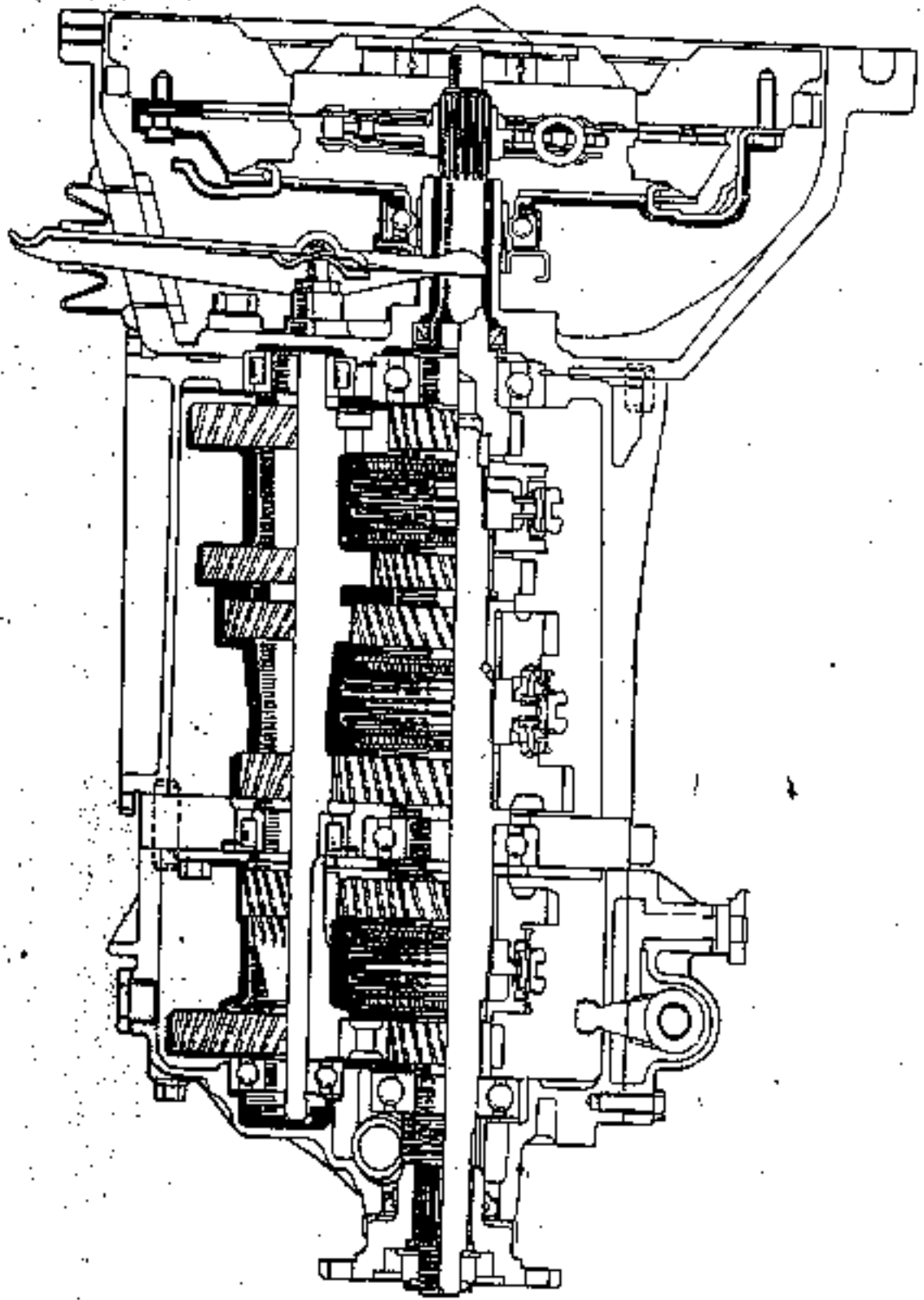



1.0	Introduction
2.0	General Information
3.0	Clutch
4.0	Shift Mechanism
5.0	Internal Gear Train
6.0	Output Shaft
7.0	Final Drive
8.0	Other Components
9.0	Diagnosis
10.0	Repair Procedures
11.0	Assembly
12.0	Adjustments
13.0	Inspection
14.0	Oil
15.0	Seals
16.0	Other
17.0	Index

**OUTLINE**

Control performance is improved by adapting the double synchronizer ring to the 1st and 2nd gear.

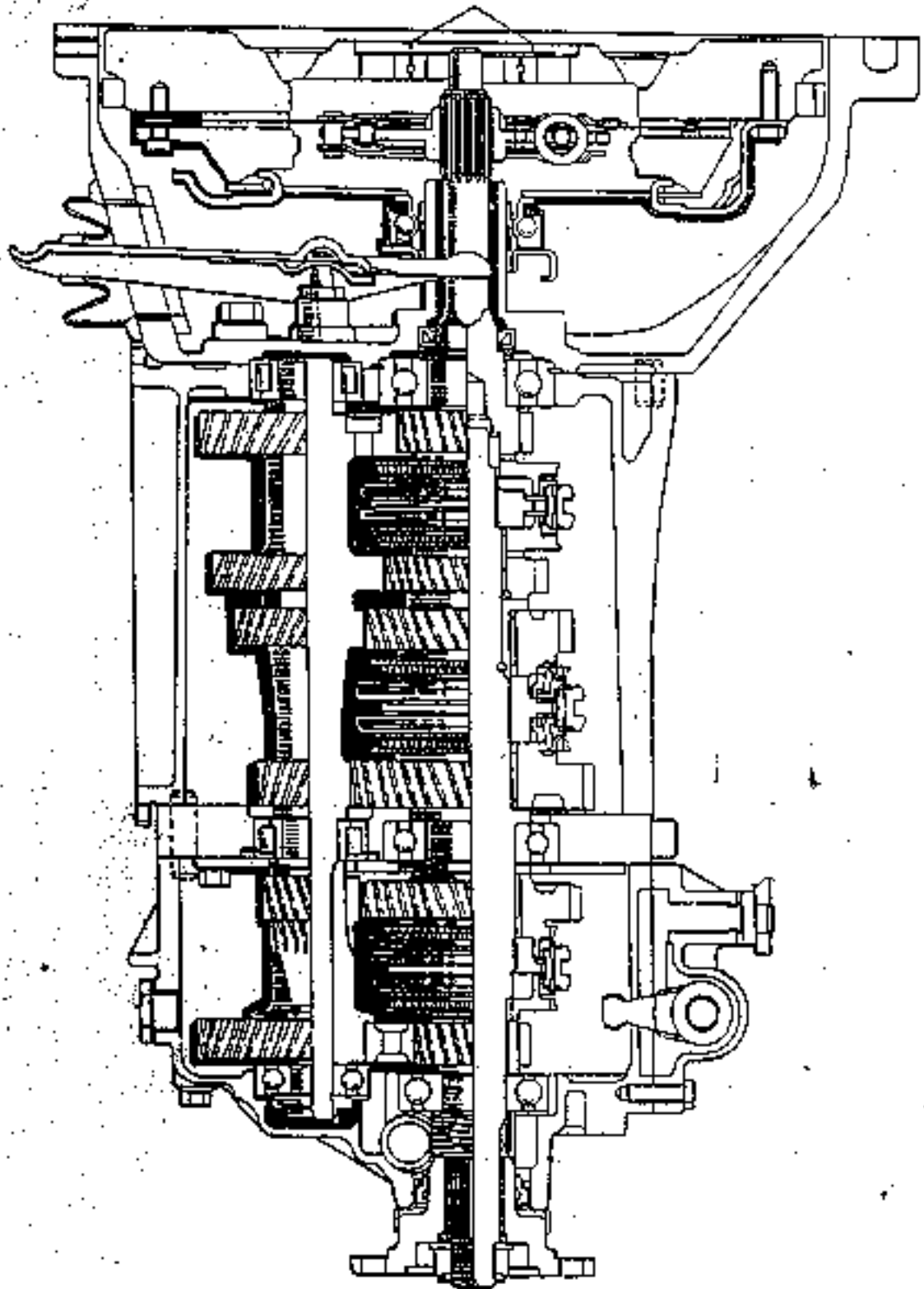

**REMOVAL/INSTALLATION**

1. Disconnect the battery negative terminal.
2. Raise the vehicle by a lift and drain the transmission oil into a suitable container.
3. Remove in the steps shown in the figure.
4. Remove referring to notes for removal.
5. Install in the reverse order of removal.

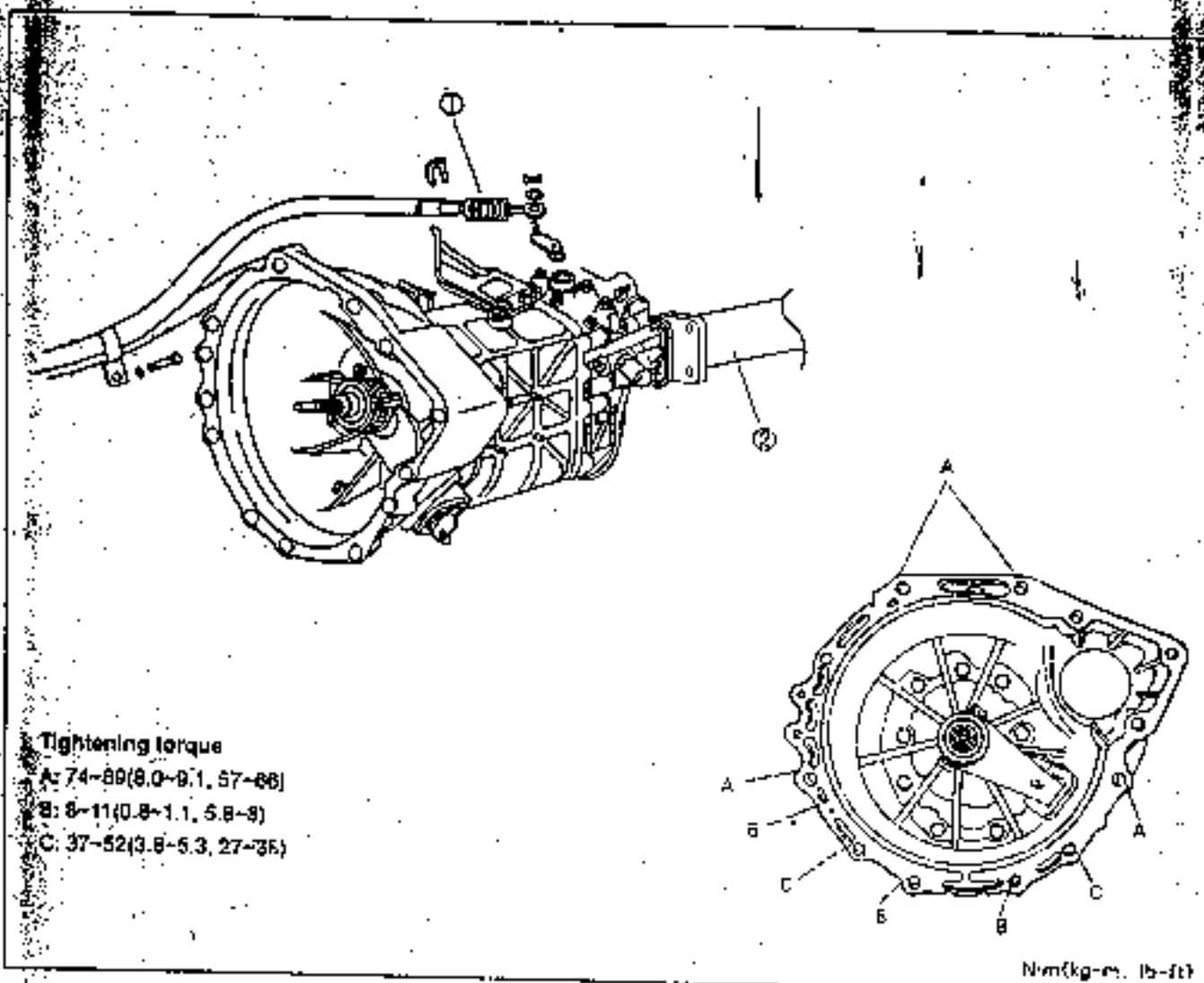

1. Transmission control cable

2. Propeller shaft

A:9041002A

**Removal note**

1. Mark the propeller shaft and transmission for identical installation position.

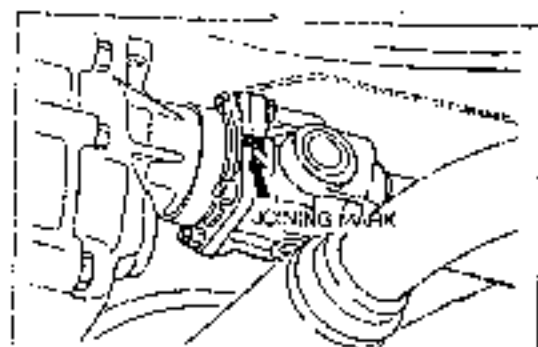

A:9041003A

DISASSEMBLY/ASSEMBLY

Note

- Clean thoroughly the transmission case with steam, air or solvent before disassembling.
- Clean the surface of all removed parts (except the ball bearing, the clutch release cylinder, and the rubber parts) with cleaning solvent, dry it with compressed air. After cleaning out all holes and passages with compressed air, check if there is clogged.

1. Remove in the steps shown in the figure, and refer to notes for disassembly.
2. Install in the reverse order of removal, and refer to notes for assembly.
3. Inspect all parts after disassembling, and repair or replace if necessary.

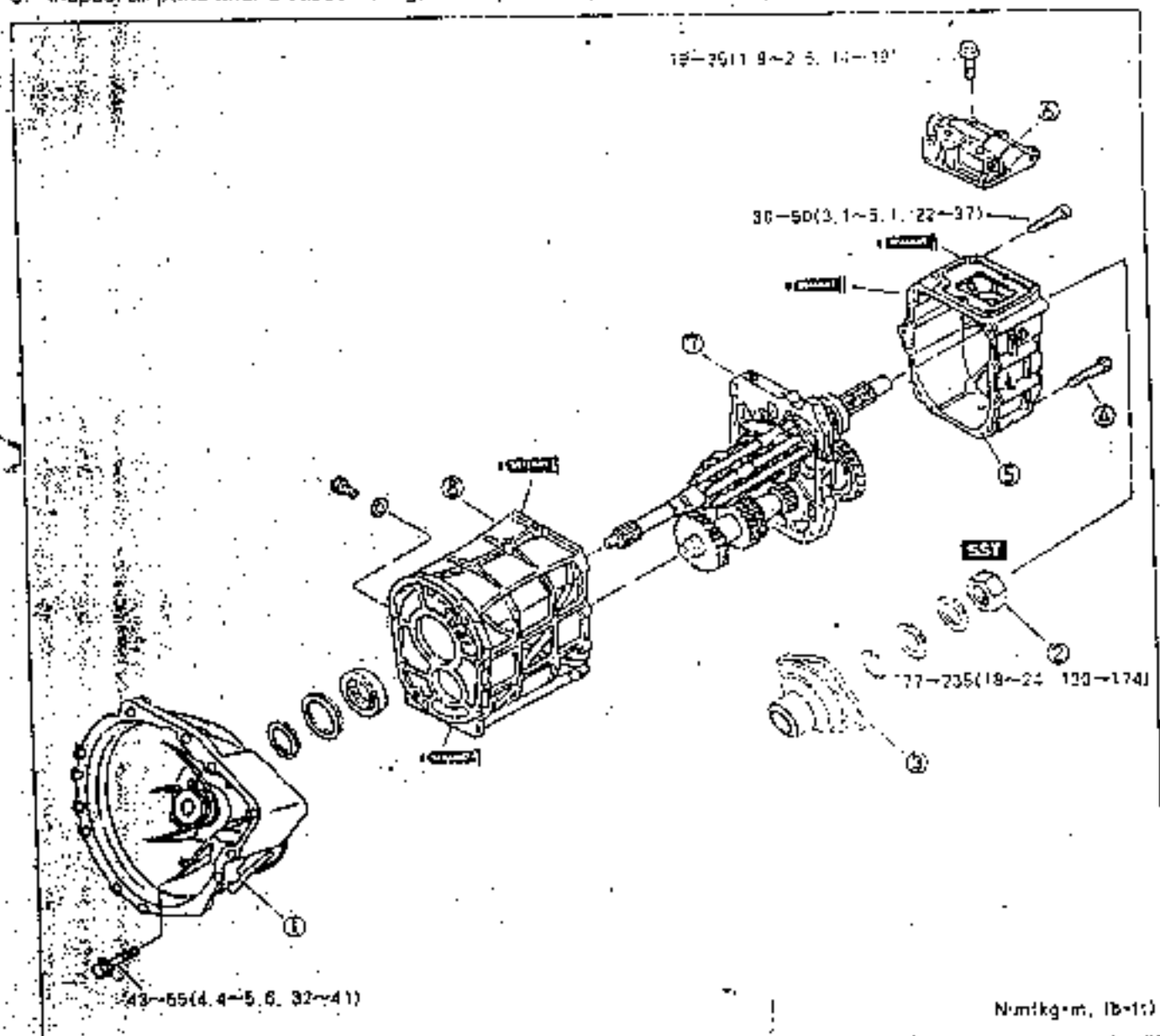

1. Clutch housing
2. Lock nut
3. Companion flange
4. Bolt

5. Rear cover assembly
6. Top cover
7. Bearing housing assembly
8. Transmission case

**Disassembly note**

1. When disassembling the lock nut, insert SST into the main drive gear and fix SST with vice and disassemble it.

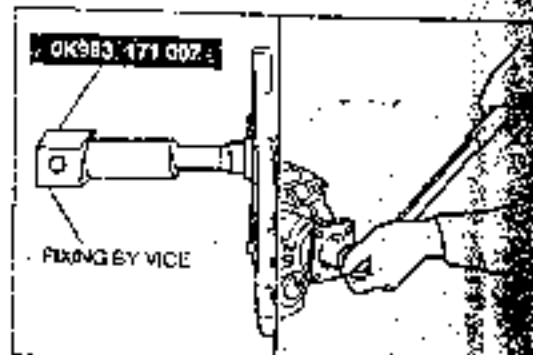
**Assembly note**

1. Apply sealant to the rear cover and the transmission case, and assemble it.

Sealant specification : TB1104, TB1215, TB1216

**Caution**

- Within 30 minutes after applying sealant, install the rear cover to the transmission case.

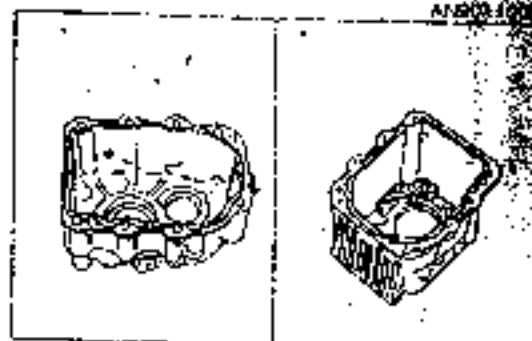

2. When tightening the top cover to the transmission case, tighten the reamer bolt and other bolts.

Tightening torque : 19-25 N·m(1.9~2.8 kg-m, 14~19 lb-ft)

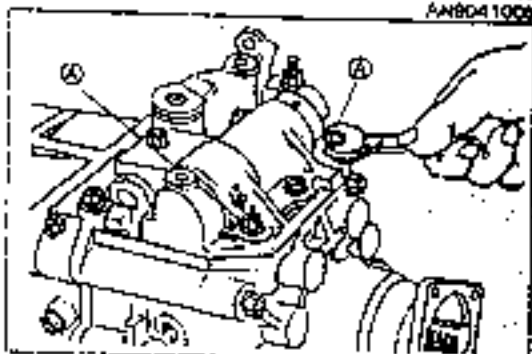

3. When assembling the rear cover, tighten the A part with a longer bolt.

Tightening torque : 30-50 N·m(3.1~5.1 kg-m, 22~37 lb-ft)

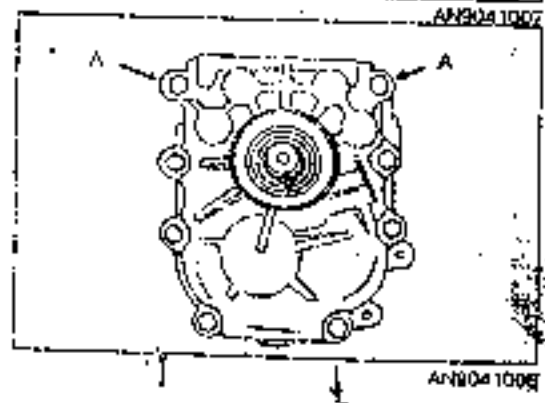

MAIN SHAFT/COUNTER SHAFT

1. Remove in the steps shown in the figure, and install in the reverse order of removal. Refer to notes for disassembly and assembly. Inspect all parts after disassembling, and repair or replace if necessary.

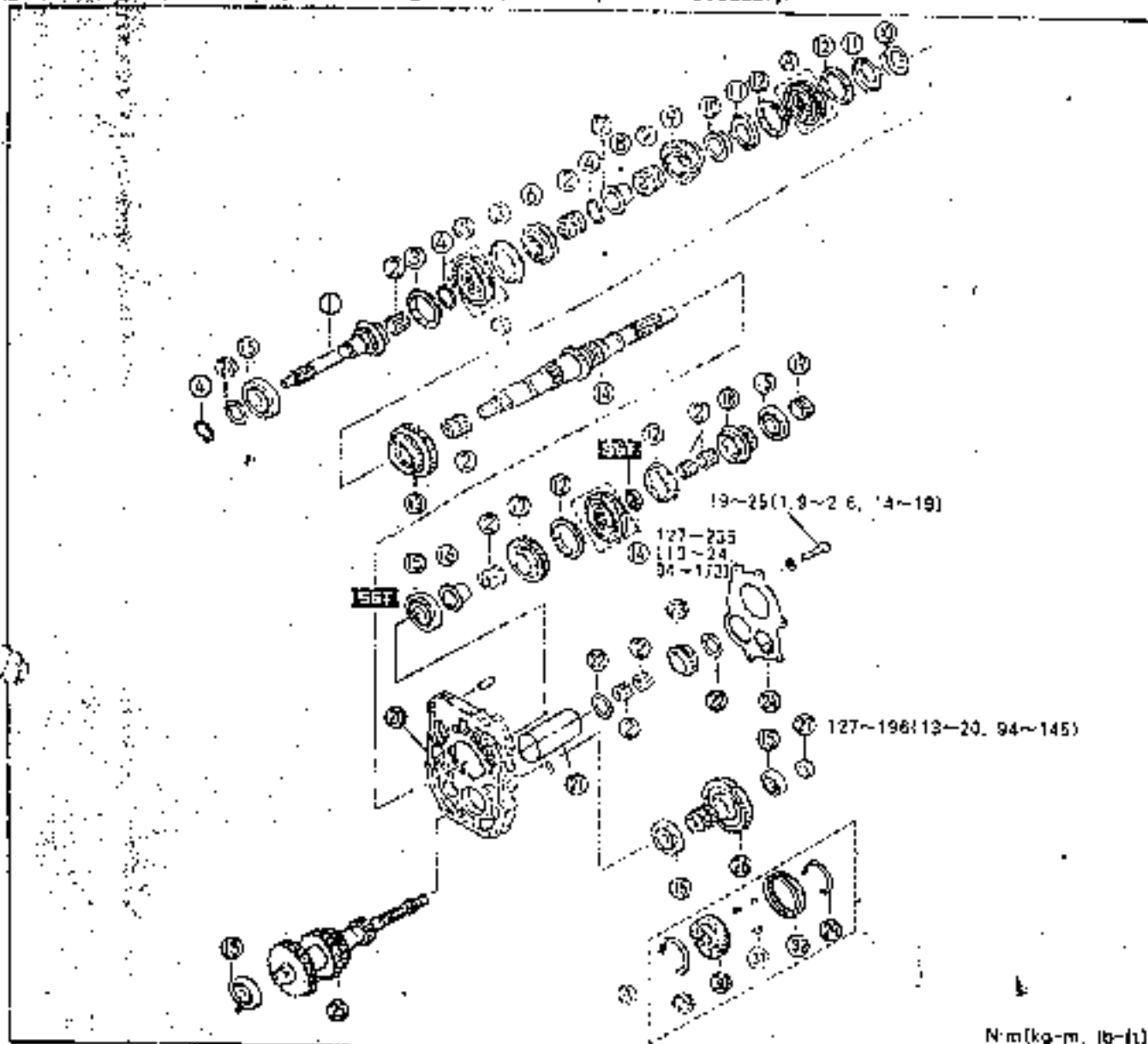

N·m(kg·m, lb-ft)

AN8341009

- |                                    |                         |                           |            |
|------------------------------------|-------------------------|---------------------------|------------|
| 1. Main drive gear                 | 11. Double cone         | 21. Idle gear shaft       | 31. Key    |
| 2. Needle bearing                  | 12. Synchronizer ring   | 22. Thrust washer         | 32. Sleeve |
| 3. Synchronizer ring               | 13. 1st gear            | 23. Reverse idle gear     |            |
| 4. Snap-ring                       | 14. Main shaft          | 24. Bearing cover         |            |
| 5. Clutch hub assembly (3rd & 4th) | 15. Bearing             | 25. Counter shaft         |            |
| 6. 3rd gear                        | 16. Reverse gear sleeve | 26. Counter gear assembly |            |
| 7. 2nd gear sleeve                 | 17. Reverse gear        | 27. Lock nut              |            |
| 8. Steel ball                      | 18. 5th gear            | 28. Shim                  |            |
| 9. 2nd gear                        | 19. Speed drive gear    | 29. Spring                |            |
| 10. Synchronizer inner ring        | 20. Bearing housing     | 30. Hub                   |            |

Caution

Be careful for the steel ball lost.

**Disassembly and Assembly note**

1. When disassembling the lock nut of the counter shaft, disassemble/assemble it after tooth matching 1st gear to reverse gear.

**Tightening torque :**

127~198 N·m(13 ~ 20 kg-m, 94~145 lb-ft)

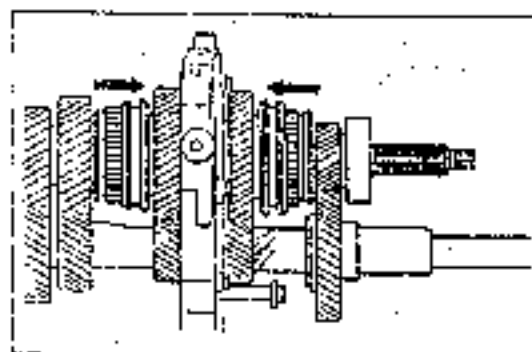

AN9041010

2. When disassembling the 5th/reverse clutch hub, disassemble / assemble it by using SST after tooth matching 4th gear, inserting to the main drive gear and fixing to vice.

**Tightening torque :**

127~235 N·m(13~ 24 kg-m, 94~174 lb-ft)

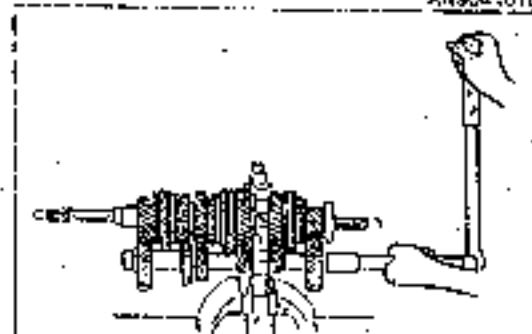

AN9341011

3. When disassembling the 3rd gear, put the puller to the 3rd gear and disassemble the clutch hub assembly, the synchronizer ring and 3rd gear in assembly by using a press.
4. When disassembling the 1st gear, disassemble the clutch hub assembly, the synchronizer ring and 1st gear in assembly by using a press.

**Caution**

- Hold it by hand to avoid being dropped.

5. When assembling the clutch hub, assemble in direction as shown in the figure and push it by press.

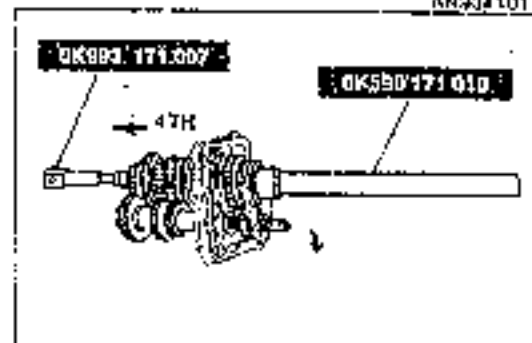

AN9241012

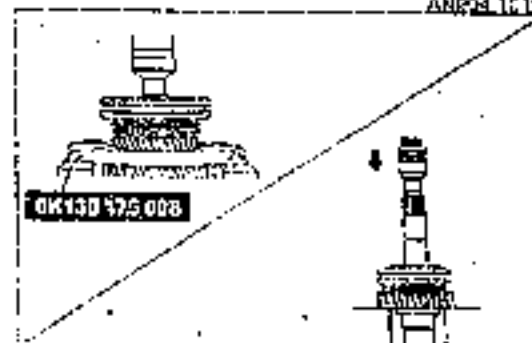

AN9041013

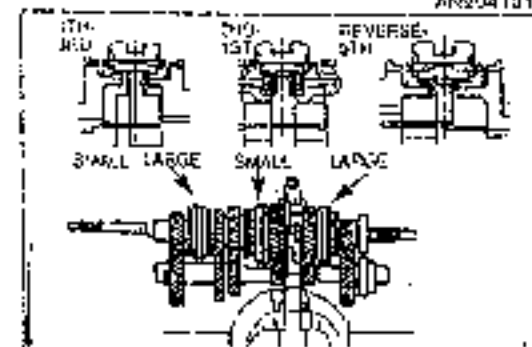

AN9341014

# 4.10 MANUAL TRANSMISSION DISASSEMBLY/ASSEMBLY

## SHIFT ROD AND TOP COVER

Refer to the steps shown in the figure, and install in the reverse order of removal.

Refer to notes for disassembly and assembly.

3. Inspect all parts after disassembling, and repair or replace if necessary.

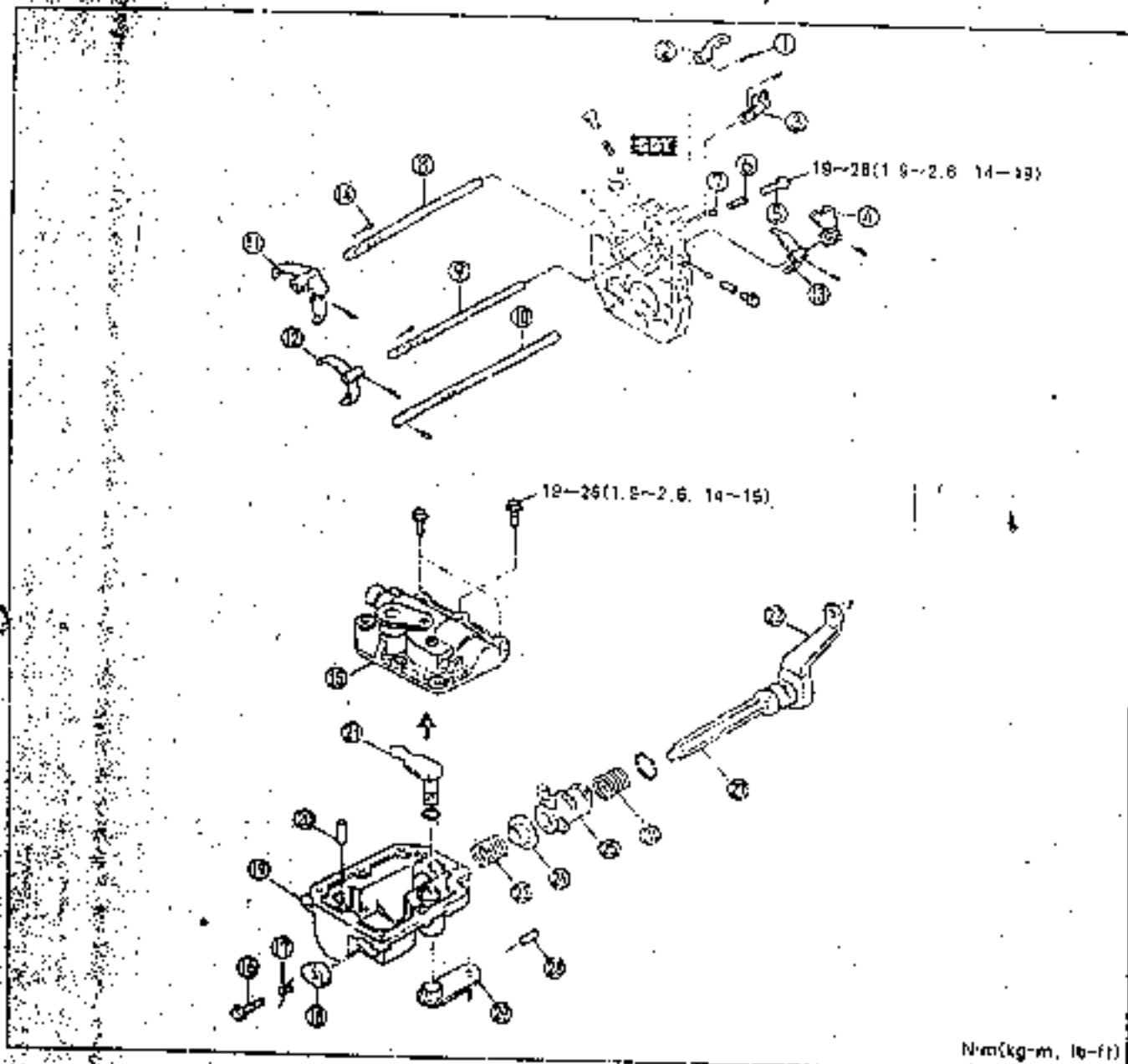

- |                               |                                |                            |
|-------------------------------|--------------------------------|----------------------------|
| 1. Spring pin                 | 11. Shift fork (1st & 2nd)     | 21. Selection arm          |
| 2. Shift end (1st & 2nd)      | 12. Shift fork (3rd & 4th)     | 22. Shift lever            |
| 3. Shift end (3rd & 4th)      | 13. Shift fork (5th & reverse) | 23. Spring (1st & 2nd)     |
| 4. Shift end (5th & reverse)  | 14. Interlock pin              | 24. Stopper                |
| 5. Bolt                       | 15. Top cover assembly         | 25. Change lever           |
| 6. Spring                     | 16. Guide bolt                 | 26. Spring (5th & reverse) |
| 7. Steel ball                 | 17. Spring                     | 27. O-ring                 |
| 8. Shift rod (1st & 2nd)      | 18. Gate                       | 28. Spring pin             |
| 9. Shift rod (3rd & 4th)      | 19. Top cover                  | 29. Select lever           |
| 10. Shift rod (5th & reverse) | 20. Spring pin                 |                            |

AN8041C15



**Disassembly and Assembly note**

Align the shift lever shaft and the shift lever for identical installation position.

2. Assemble the interlock pin into the center of the bearing housing by using SST.

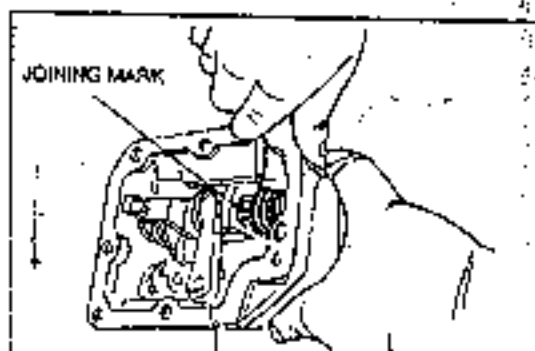

AN2041016

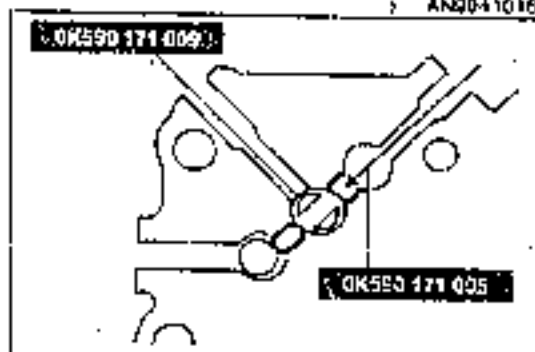

AN2041017

3. Assemble the ball spring plug by using a hexagon wrench. Pay attention to length of the plug.

Long plug : for 3rd & 4th gear

Tightening torque : 19~25 N·m(1.9~2.6 kg·m, 14~19 lb·ft)

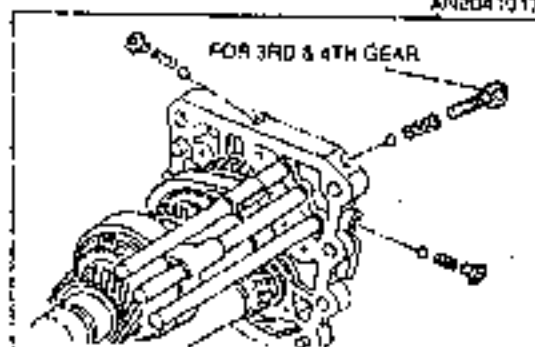

AN2041018

**ADJUSTMENT OF BEARING SHIM**

1. Measure the height (D) of part to where the main bearing of clutch housing is installed.
2. Measure the height (H) from the front end of bearing to the surface of transmission casing.

Measure clearance : D-H

3. Adjust the standard clearance by using the adjusting shim.

Standard clearance : 0~0.1 mm(0~0.004 in)

Thickness of adjusting shim :

0.10 mm, 0.15 mm, 0.30 mm(0.004 in, 0.006 in, 0.012 in)

4. After inserting the shim, tighten the clutch housing to the transmission.

Tightening torque : 43~55 N·m(4.4~5.6 kg·m, 32~41 lb·ft)

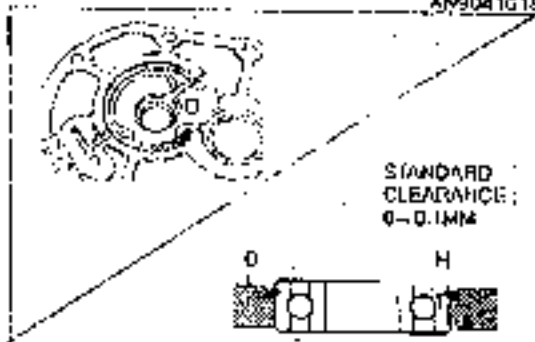

STANDARD CLEARANCE :  
0~0.1MM

AN2041019

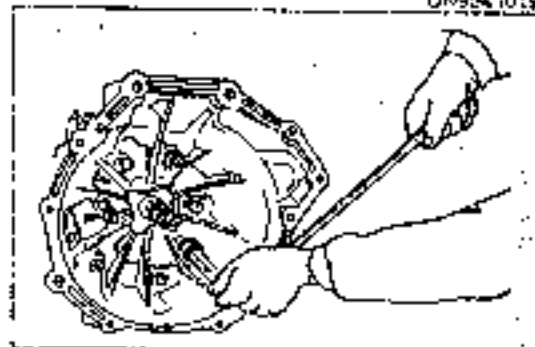

AN2041020

**INSPECTION**

**Main Shaft**

1. Check the runout of shaft.

Runout : 0.03 mm (0.012 in)

2. Measure the thickness of shaft flange.

Standard : 7.46 ~ 7.55 mm (0.293 ~ 0.297 in)

3. Measure the inner diameter of sleeve of reverse gear and the outer diameter of main shaft.

Outer diameter of shaft :

37.022 ~ 37.003 mm (1.4575 ~ 1.4568 in)

Inner diameter of sleeve :

37.040 ~ 37.056 mm (1.4582 ~ 1.4588 in)

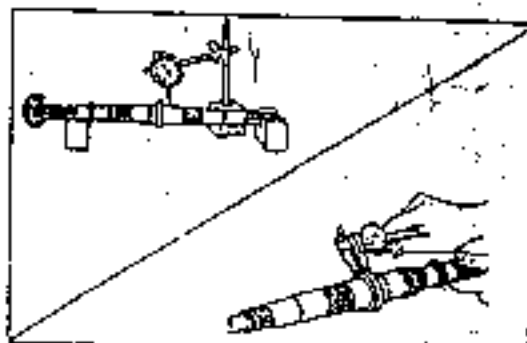

AN9041021

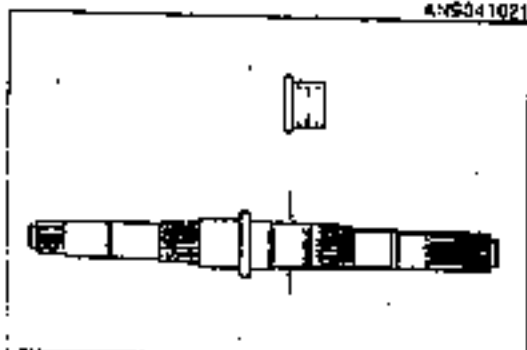

AN9041022

**Synchronizer Ring**

1. Measure the side clearance of the synchronizer ring and gear on its circumference after correctly putting the synchronizer ring on the gear.

Standard clearance

Double synchronizer ring : 1.3 mm (0.051 in)

Single synchronizer ring : 1.5 mm (0.059 in)

Limit : 0.6 mm (0.0315 in)

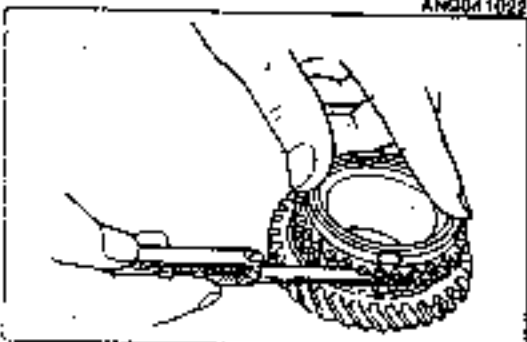

AN9041023

**Clutch Hub Sleeve**

1. Measure the clearance of the clutch hub and shift fork.

Standard clearance : 0.2 ~ 0.3 mm (0.0078 ~ 0.0118 in)

Limit : 0.8 mm (0.0315 in)

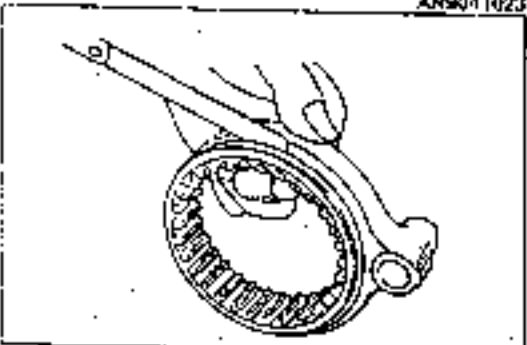

AN9041024

## CHANGE CONTROL

## DISASSEMBLY/ASSEMBLY

1. Remove in the steps shown in the figure.
2. Inspect all parts, and repair or replace if necessary.
3. Install referring the notes for installation.

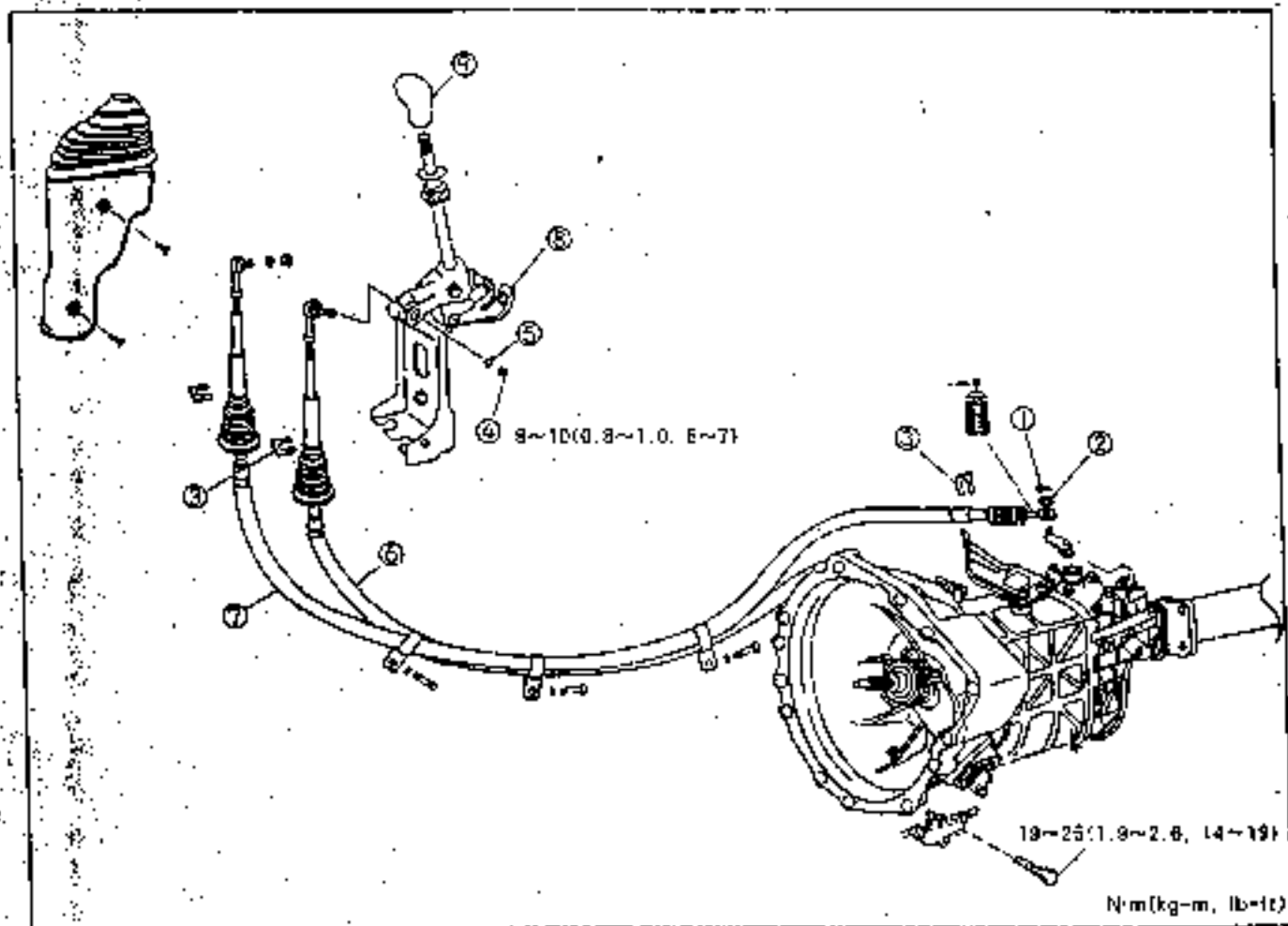

ANB041025

1. Snap pin
2. Washer
3. Clip

4. Nut
5. Spring washer
6. Shift cable

7. Select cable
8. Change lever assembly
9. Knob

## Installation note

1. Hold the cable end (A) and install it during paying attention to it not to be bent.
2. Note the color of select cable is red.

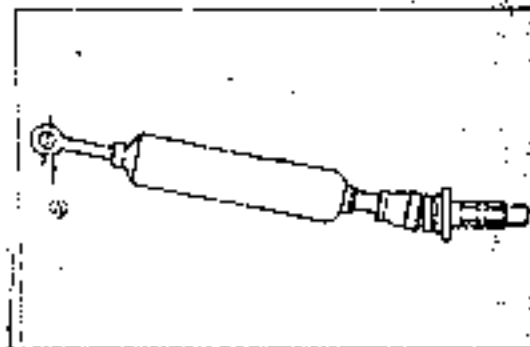

ANB041025

# 41-14 MANUAL TRANSMISSION SPECIFICATIONS

## INSPECTION/ADJUSTMENT

1. When the change lever is trembled in left and right, loosen the nut ① and tighten after adjusting.

Tightening torque : 10~15 N·m(1.0~1.5 kg·m, 7~11 lb·ft)

2. When the change lever is trembled in back and forth, loosen the nut ② and tighten after adjusting.

Tightening torque : 10~15 N·m(1.0~1.5 kg·m, 7~11 lb·ft)

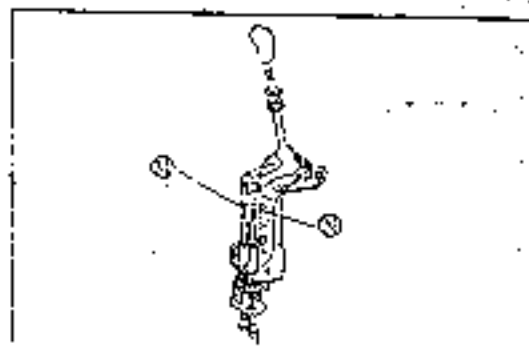





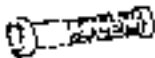

AN8041027

## SPECIFICATIONS

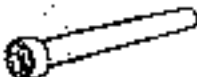
Items		Specifications	
		12 seats Standard	15 seats Standard
Type:		Forward : 5-speed, Reverse : 1-speed Synchro mesh (1st and 2nd) . Double synchro)	
Gear ratio	1st	4.011	4.419
	2nd	2.272	2.643
	3rd	1.425	1.538
	4th	1.000	1.000
	5th	0.831	0.685
	Reverse	3.956	4.432
Oil	Capacity (qt)	2.2(2.32)	
	Grade	API Service Class GL4 Four Seasons ; SAE 75W-80	

## SPECIAL TOOLS

<p>OK593 171 007</p> <p>Main shaft holder</p> 	<p>Fixing drive shaft</p>	<p>OK590 170 004</p> <p>Main drive gear installer</p> 	<p>Assembling bearing</p>
<p>OK570 990 AAD</p> <p>Bearing puller set</p> 	<p>Removing bearing</p>	<p>OK590 171 009</p> <p>Shift fork guide assembly</p> 	<p>Assembling interlock pin</p>
<p>OK590 171 010</p> <p>Main shaft lock nut wrench</p> 	<p>Assembling/ Disassembling lock nut of hub</p>	<p>OK590 171 005</p> <p>Interlock pin guide</p> 	<p>Assembling interlock pin</p>
<p>OK130 275 008</p> <p>Fan pulley boss puller</p> 	<p>Removing gear and bearing</p>	<p>OK590 170 007/008</p> <p>Transmission bearing installer</p> 	<p>Assembling bearing</p>

# PROPELLER SHAFT

43

INSPECTION .....	43- 7
DISASSEMBLY/ASSEMBLY .....	43- 5
SPECIFICATIONS .....	43- 8
OUTLINE .....	43- 3
TROUBLESHOOTING GUIDE .....	43- 4

OUTLINE

STRUCTURAL VIEW

12 seats A/T

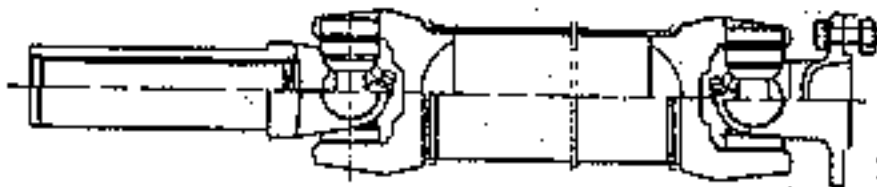

12 seats M/T

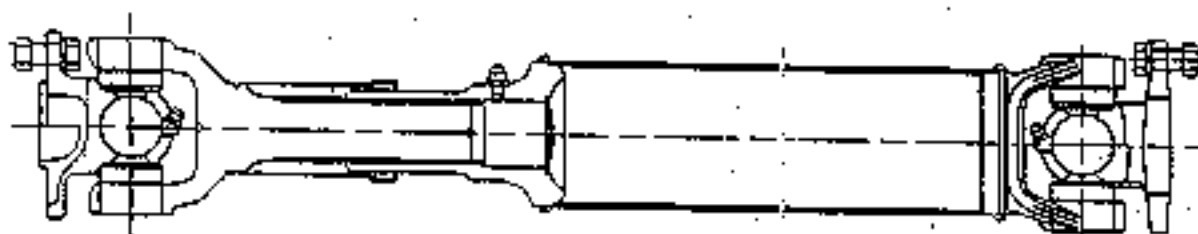

15 seats M/T

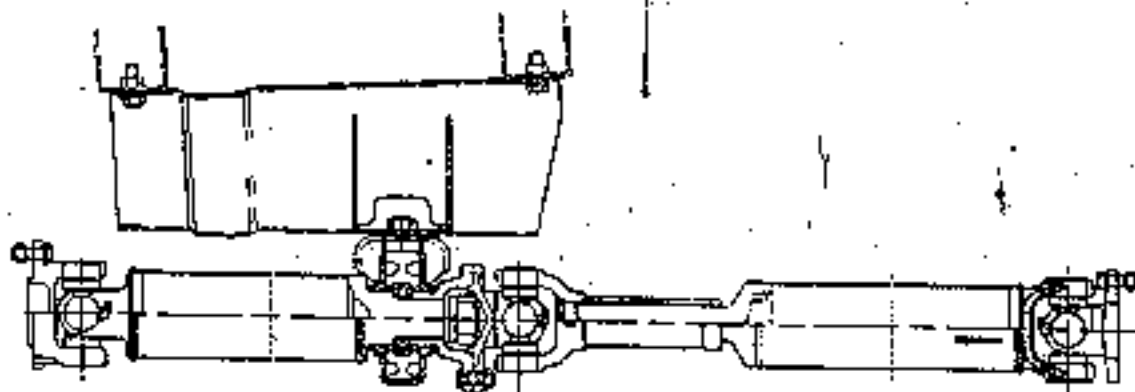

## TROUBLESHOOTING GUIDE

Problem	Possible cause	Action
Vibration	Bent propeller shaft Imbalanced propeller shaft Cracked sleeve yoke spline Loose yoke joints	Replace Repair Replace Tighten
Noise	Cracked sleeve yoke spline Worn or cracked spider bearing Loose yoke joints	Replace Replace Tighten

## INSPECTION

**Spline backlash**

1. Check for loose yoke joints and tighten if necessary.
2. Check for spline and universal joints backlash.

**Bend**

1. Raise the vehicle and support it with safety stand.
2. Measure how sharply propeller shaft is bent by turning wheels by hand and replace if necessary.

Limit : 0.4 mm(0.016 in)

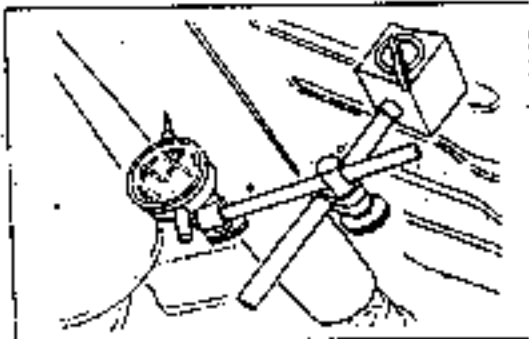

AM9043001



# DISASSEMBLY/ASSEMBLY

12 seals

AT

49-58(5.0-8.0. 38-43)

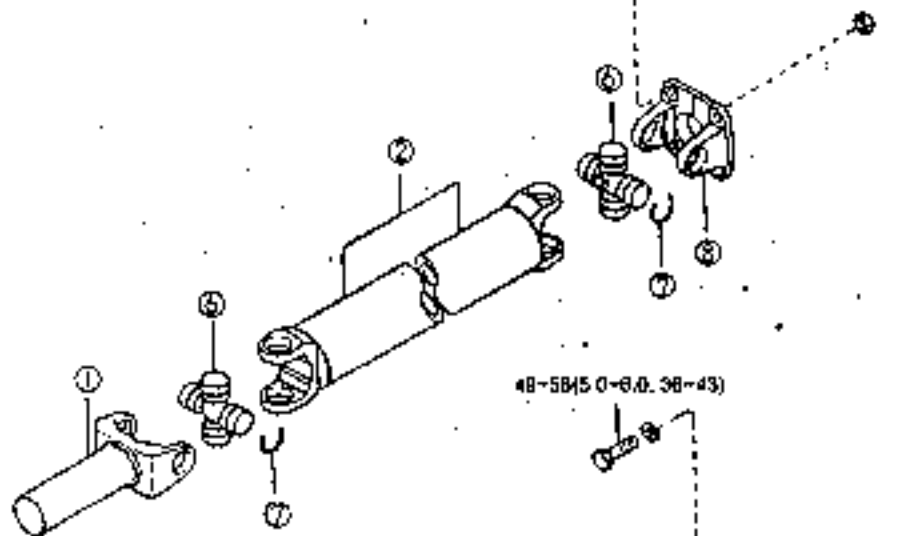

M/T

48-58(5.0-8.0. 38-43)

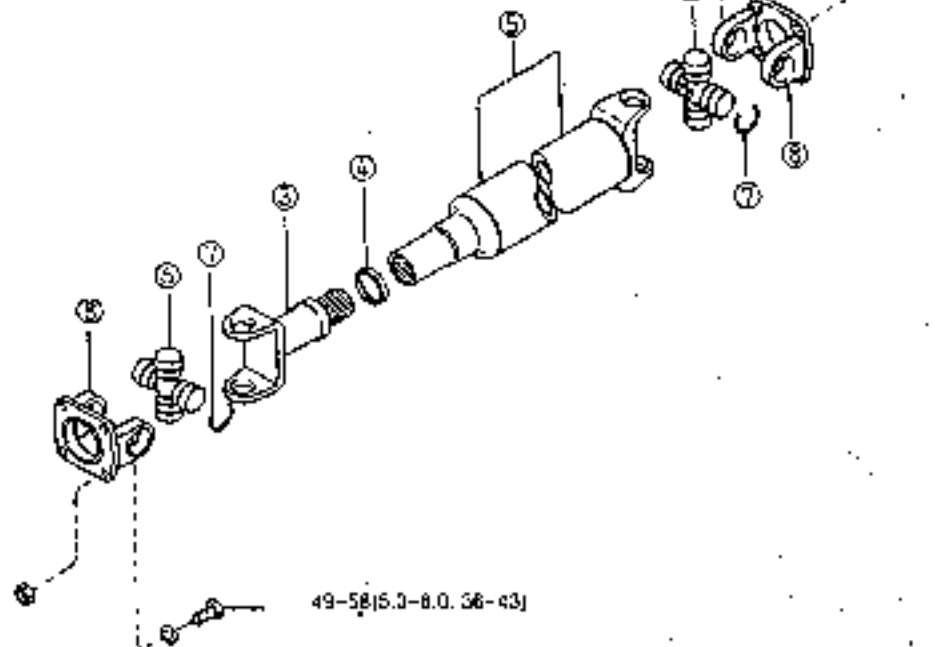

49-58(5.0-8.0. 38-43)

N-m(kg-m. 10-14)

AN5013010

1. Sliding yoke(AT)
2. Propellar shaft(AT)
3. Sliding joint(M/T)
4. Dust seal
5. Universal joint yoke

6. Universal joint
7. Snap ring
8. Universal joint

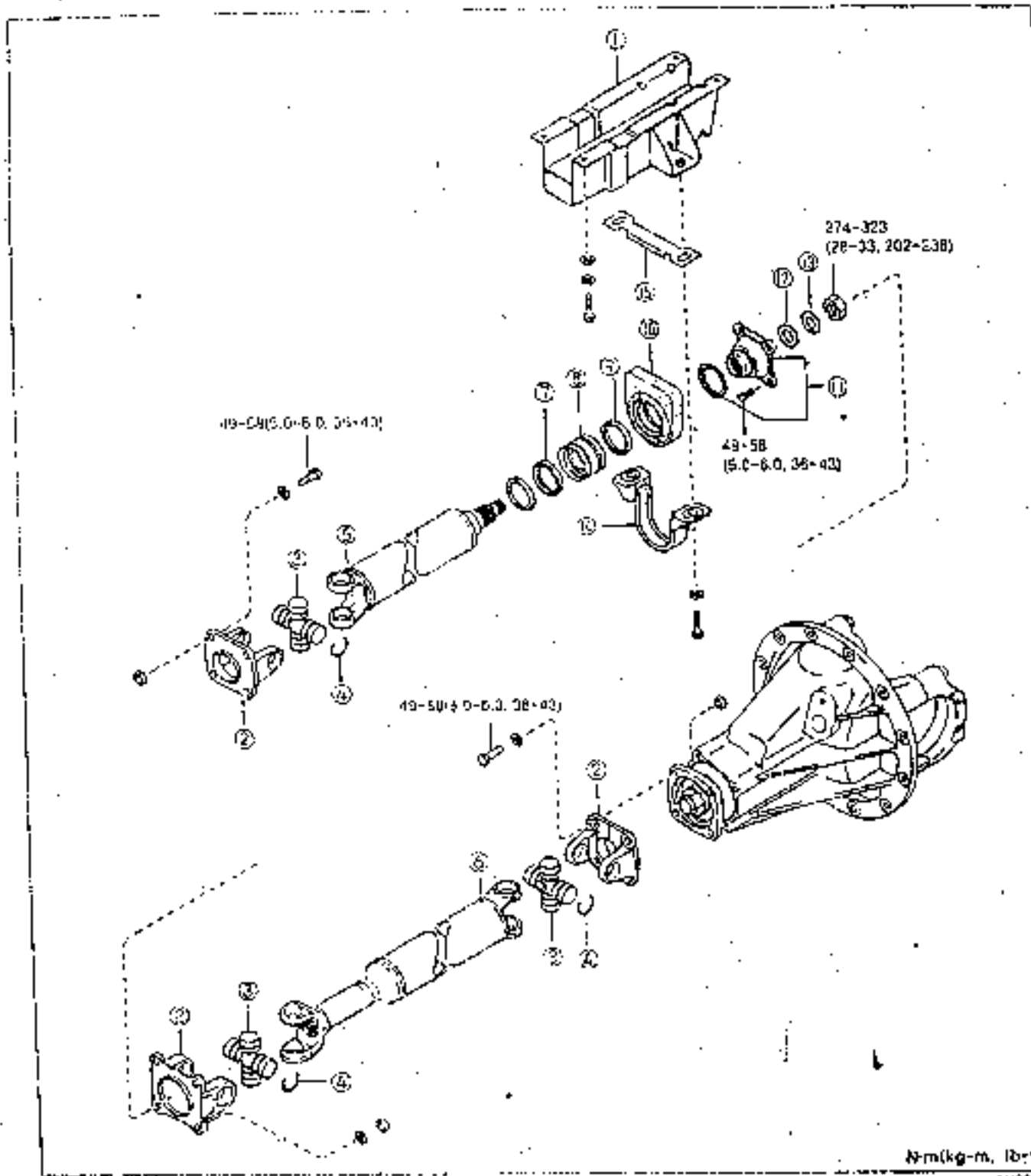

- |                               |                              |                            |
|-------------------------------|------------------------------|----------------------------|
| 1. Center bearing bracket     | 6. Rear universal joint yoke | 11. Companion flange       |
| 2. Universal joint yoke       | 7. Front oil seal            | 12. Plain washer           |
| 3. Universal joint            | 8. Center bearing            | 13. Washer spring          |
| 4. Snap ring                  | 9. Rear oil seal             | 14. Center bearing support |
| 5. Front universal joint yoke | 10. Center bearing rubber    | 15. Rubber holder          |

AN0043011

### DISASSEMBLY NOTE

1. Mark spider, yoke and propeller shaft for reassembling.

#### Caution

- Incomplete joint between propeller shaft spider and yoke at the time of assembly may cause vibration.

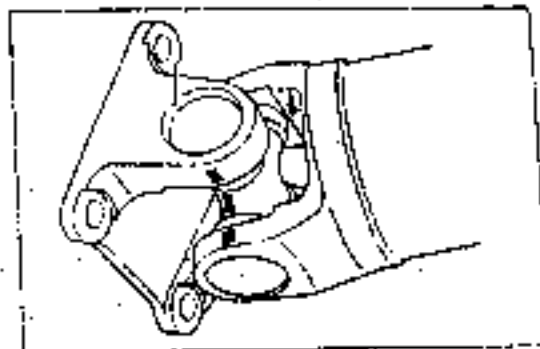

AI 5043000

### ASSEMBLY NOTE

1. Apply grease to spider and bearing.
2. Assemble yoke and spider to propeller shaft, and bearing to yoke by tapping with a plastic hammer.

#### Caution

- Be sure to have assembly marks of spider and yoke go exactly right.

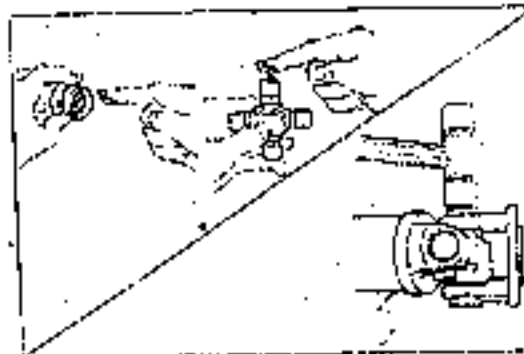

AI 5043000

3. Assemble with a new snap ring.

#### Caution

- Do not reuse snap rings.
- Use four(4) snap rings with same thickness.
- Ensure snap rings be completely seated and firm.

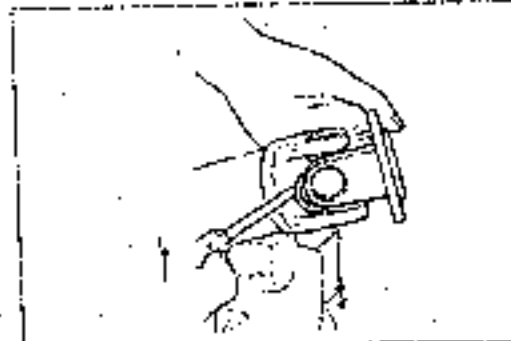

AI 5043000

### INSPECTION

1. Check for bend of propeller shaft.

#### Note

- Measure from the center of propeller shaft.

Limit : 0.4 mm(0.016 in)

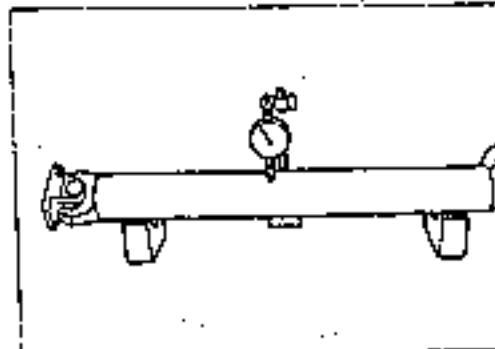

AI 5043000

2. Check moving torques of universal joints.

Torque : A/T : 0.3~0.8 N·m(3~8 kg·cm, 2.6~7 lb·in)  
M/T : 0.5~1.4 N·m(5~14 kg·cm, 4.3~12 lb·in)

#### Caution

- Replace and adjust snap rings if the torques are not within specification. (Refer to Page 43-8)

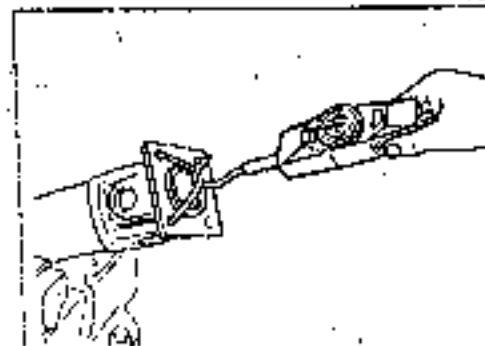

AI 5043000

## SPECIFICATIONS

## 1. Length (between joints) and Diagram

Propeller shaft		Standard length		Outer diameter D (mm)
		Front	Rear	
12 seats	A/T	777(30.6)		ø 83.5(2.5)
	M/T	888-997(36.9-39.3)		ø 76.2(3)
15 seats	M/T	557(21.8)	601-615(31.5-32.0)	ø 76.2(3)

## 2. Snap ring

A/T

Part number	Thickness	Part number	Thickness
01757 25 171	1.22(0.048)	01757 25 178	1.32(0.0519)
01757 25 172	1.24(0.0488)	01757 25 177	1.34(0.0527)
01757 25 173	1.26(0.0496)	01757 25 179	1.36(0.0536)
01757 25 174	1.28(0.0504)	01757 25 176	1.38(0.0543)
01757 25 175	1.30(0.0511)		

M/T

Part number	Thickness	Part number	Thickness
0W001 25 171A	1.45(0.057)	0W001 25 175A	1.83(0.0721)
0W001 25 172A	1.48(0.0582)	0K410 25 071	1.60(0.0629)
0W001 25 173A	1.54(0.0606)	0K421 25 071	1.50(0.590)
0W001 25 174A	1.57(0.0618)		

## 3. Tightening torque

Transmission x propeller shaft	A/T	N.m(kg-m, lb-ft)
	M/T	
Propeller shaft x differential	M/T	49-59(5.0-6.0, 36.3-43.5)
	M/T	49-59(5-6, 36.3-43.5)

# FRONT AND REAR AXLE

50

DIFFERENTIAL .....	50- 8
FRONT AXLE .....	60- 4
REAR AXLE .....	50- 6
SPECIAL TOOLS .....	50-18
SPECIFICATIONS .....	60-18
TROUBLESHOOTING GUIDE .....	50- 3

## TROUBLESHOOTING GUIDE

## FRONT AXLE

Problem	Possible cause	Action
Steering wheel vibration	Improper adjustment of wheel bearing Worn or damaged wheel bearing	Adjust Adjust
Dragging or pulls to one side	Worn or damaged wheel bearing Improper adjustment of wheel bearing	Replace Adjust
Excessive clearance of steering wheel	Poor adjustments of wheel bearing	Adjust

## REAR AXLE

Problem	Possible cause	Action
Abnormal noise	Bearing housing bent Drive shaft bent Worn or damaged wheel bearing Worn drive shaft spline	Replace Replace Replace Replace
Oil leaks	Worn or broken oil seal	Replace

## DIFFERENTIAL GEAR

Problem	Possible cause	Action
Abnormal noise	Shortage of differential oil Improper adjustment of ring gear backlash Improper adjustment of ring gear backlash Poor engagement of ring gear surfaces Worn or damaged side bearing Worn or broken ring gear Worn or damaged drive pinion bearing Worn or damaged pinion and side gear Side gears contact with its case Worn gear spline Worn pinion shaft Loose companion flange nuts Worn thrust washer Improper adjustment of side bearing preload Worn output shaft spline	Add oil Replace Adjust Adjust Replace Replace Replace Replace Replace Replace Replace Replace Tighten Replace Adjust Replace
Overheat	Shortage of differential oil Gear backlash shortage Excessive bearing preload	Add oil Adjust Adjust
Oil leaks	Too much differential oil Air hole clogged Loose differential carrier Worn or damaged oil seal	Remove oil Repair Tighten and repair Replace
Differential gear malfunction	Improper assembly	Repair

## FRONT AXLE

## REMOVAL/INSTALLATION

1. Remove as shown in the figure.
2. Check parts if necessary. Repair or replace as required.
3. Install in the reverse order of removal.
4. After installation, check wheel alignment.

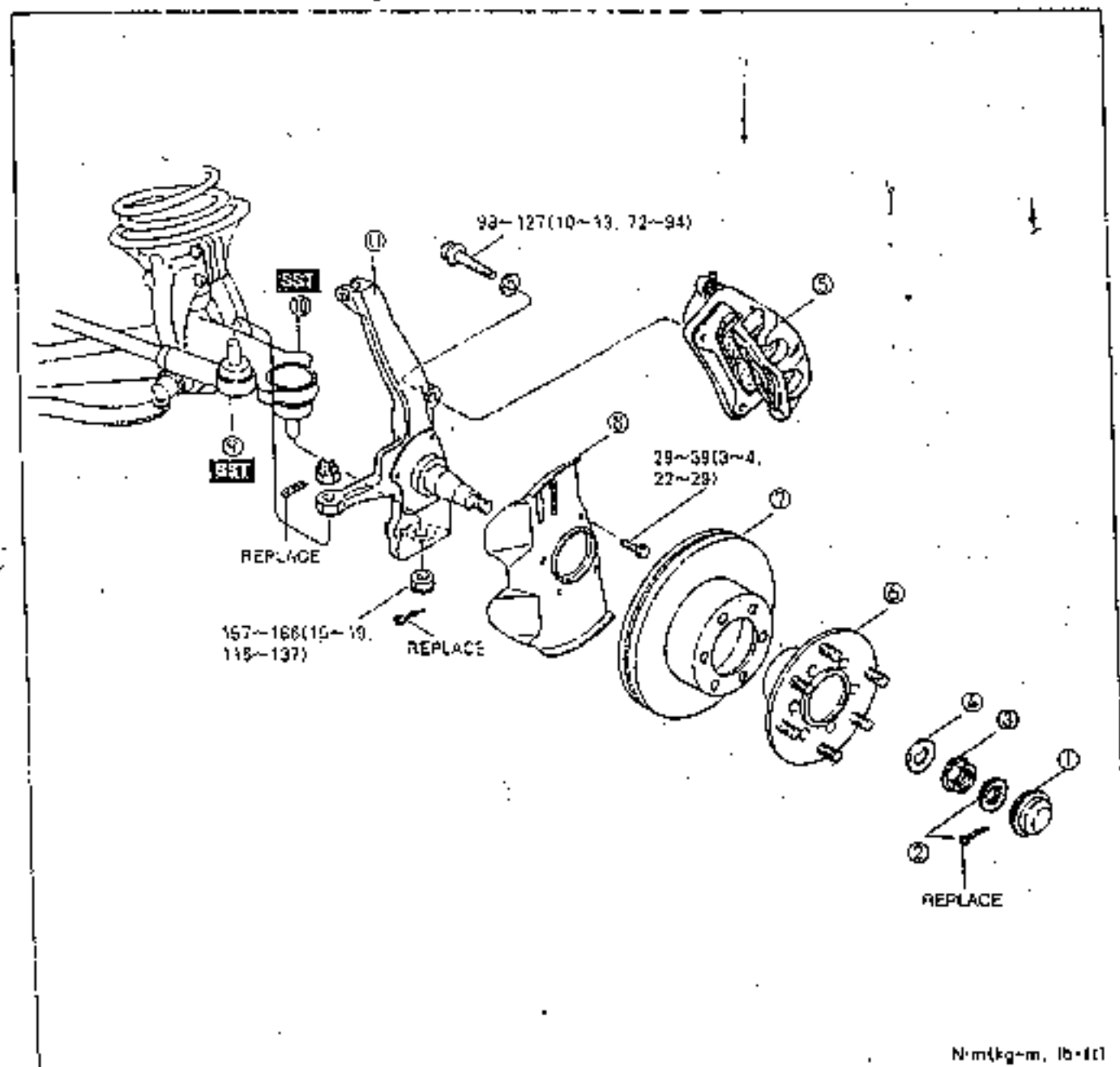

N·m(kg-m, lb-ft)

AN905001

- |                               |                     |
|-------------------------------|---------------------|
| 1. Hub cap                    | 7. Disc plate       |
| 2. Dividing pin and cover set | 8. Dust cover       |
| 3. Lock nut                   | 9. Tie-rod end      |
| 4. Washer                     | 10. Lower arm       |
| 5. Brake caliper assembly     | 11. Knuckle spindle |
| 6. Front wheel hub assembly   |                     |

**INSPECTION****Wheel bearing play**

1. Remove wheels and tires.
2. Remove brake caliper assembly.
3. Install dial gauge to wheel hub and measure wheel bearing play by pushing and pulling it to the shaft direction. Replace wheel bearing if necessary.

Bearing play : 0.025-0.152 mm(0.001-0.006 in)

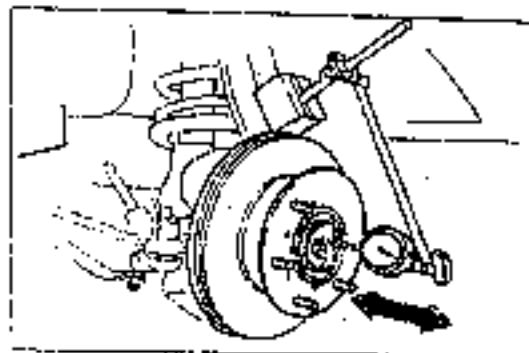

AN8050602

**REMOVAL NOTE****Tie-rod end****Caution**

- Be sure not to damage dust boot.

1. Loosen nut and remove tie-rod end using SST.

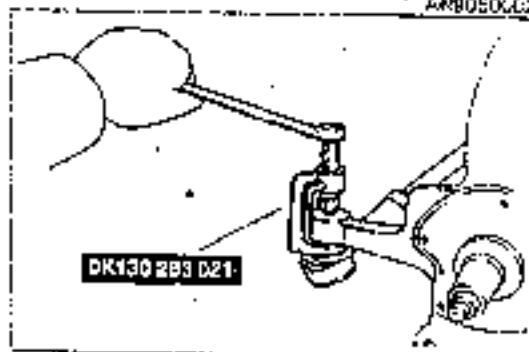

AN8050603

**Lower arm**

1. Loosen nut and remove lower arm using SST.

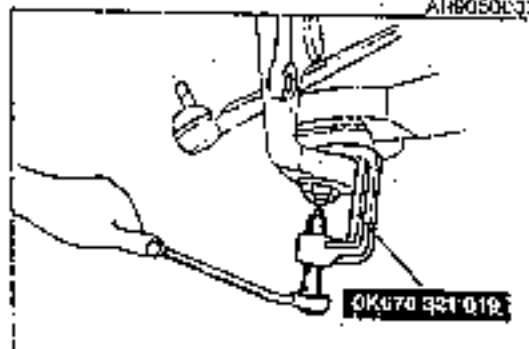

AN8050604



## REAR AXLE

## REMOVAL/INSPECTION/INSTALLATION

1. Remove as shown in the figure
2. Check all parts, and repair or replace as required.
3. Install in the reverse order of removal.

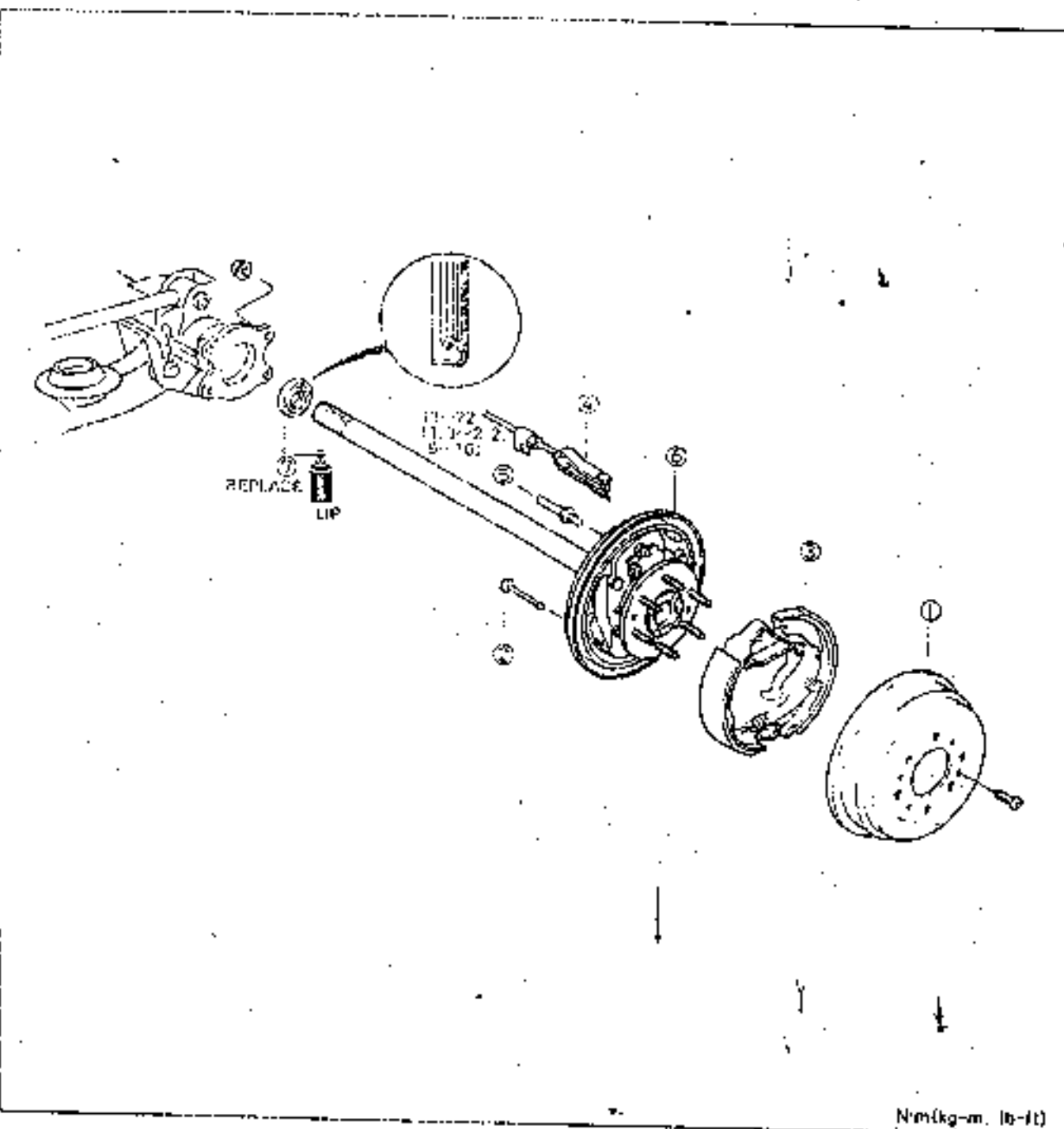

1. Brake drum
2. Hold pin
3. Brake shoe assembly
4. Parking brake cable

5. Brake pipe
6. Backing plate and rear axle shaft assembly
7. Oil seal

N·m(kg-m, lb-ft)

AN6050005

**DISASSEMBLY/ASSEMBLY**

1. Disassemble as shown in the figure.

**Caution**

- Pay an extra attention to bearing lock nut of left wheel as it is left-handed nut.

2. Assemble in the reverse order of disassembly.

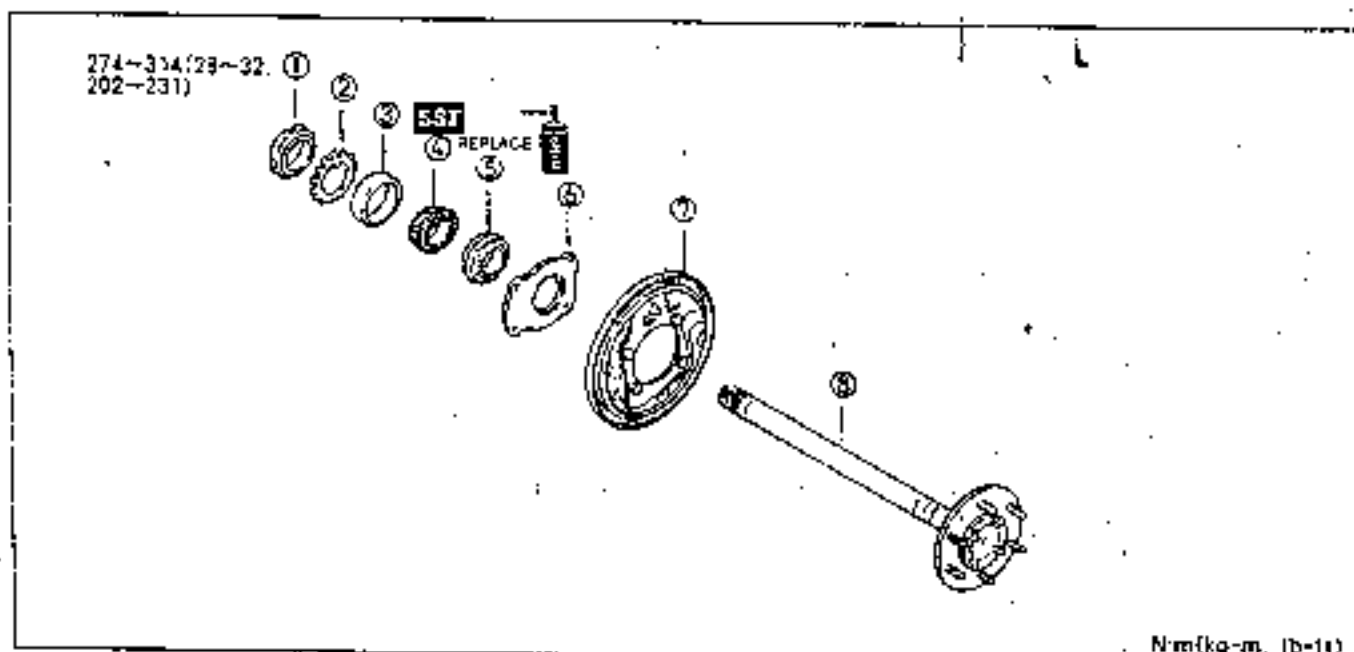

1. Lock nut
2. Lock washer
3. Bearing outer race
4. Wheel bearing

5. Oil seal
6. Oil seal retainer
7. Backing plate
8. Rear axle shaft

**DISASSEMBLY NOTE****Bearing****Caution**

- Put the protecting pad to the vise.

1. Remove bearing using SST.
  - Specification of grease : SHELL RETINAX LX2 or equivalent

**INSPECTION****Rear axle shaft**

1. Measure shaft runout with the dial gauge.
2. Adjust axle shaft if runout is not within specification.

Runout : 0.5 mm(0.2 in)

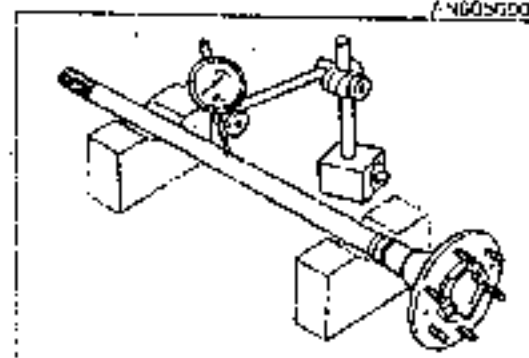
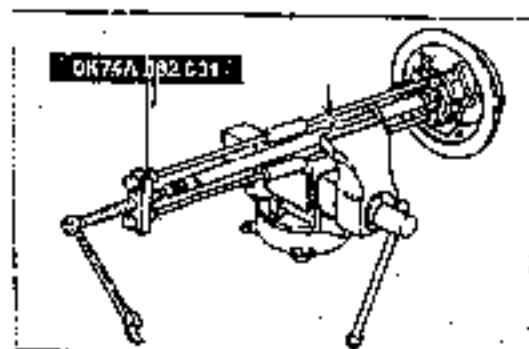

**DIFFERENTIAL****DIFFERENTIAL OIL CHECK****Inspection**

1. Remove filler plug.
2. Check if oil is enough to be seen from the filling hole. Supply more regular oil if oil is not enough.
3. Assemble filler plug.

Tightening torque : 39~54 N·m(4.0~5.5 kg·m, 29~40 lb·ft)

**Replacement**

1. Remove drain and filler plug and drain oil.
2. Clean plug.
3. Put sealant on the thread of drain plug.
4. Put new washer and tighten drain plug.

Tightening torque : 39~54 N·m(4.0~5.5 kg·m, 29~40 lb·ft)

5. Add oil until the level reaches filling hole.

**Regular oil**

Spec. : Higher than -18°C(-0.4°F) : API GL-5, SAE 90

Lower than -18°C(-0.4°F) : API GL-5, SAE 80

Qty : 1.3L(1.37 qt)-12 seats, 1.6L(1.69 qt)-15 seats

6. Tighten filler plug.

Tightening torque : 39~54 N·m(4.0~5.5 kg·m, 29~40 lb·ft)

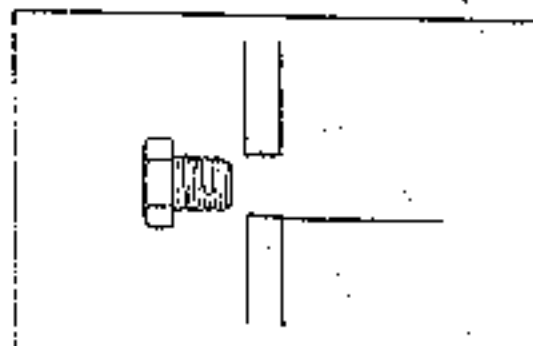

AN8050003

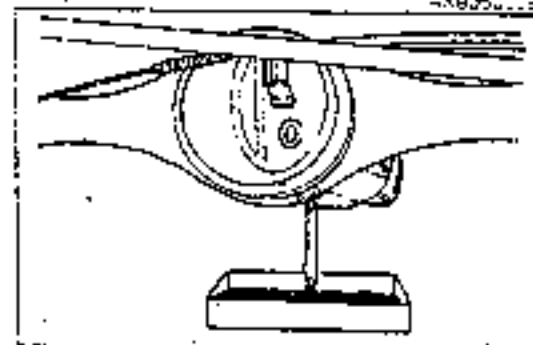

AN8050003

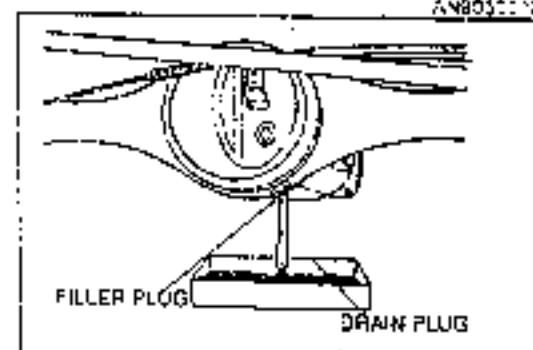

AN8050001

REMOVAL/INSTALLATION

1. Remove as shown in the figure.

Caution

• Install differential within 10 min. after applying sealant. Wait for about 30 min. before filling oil.

2. Install in the reverse order of removal.

MTX 49~59(5~6, 36~43)  
 ATX 45~59(4, 6~8, 0, 33~43)

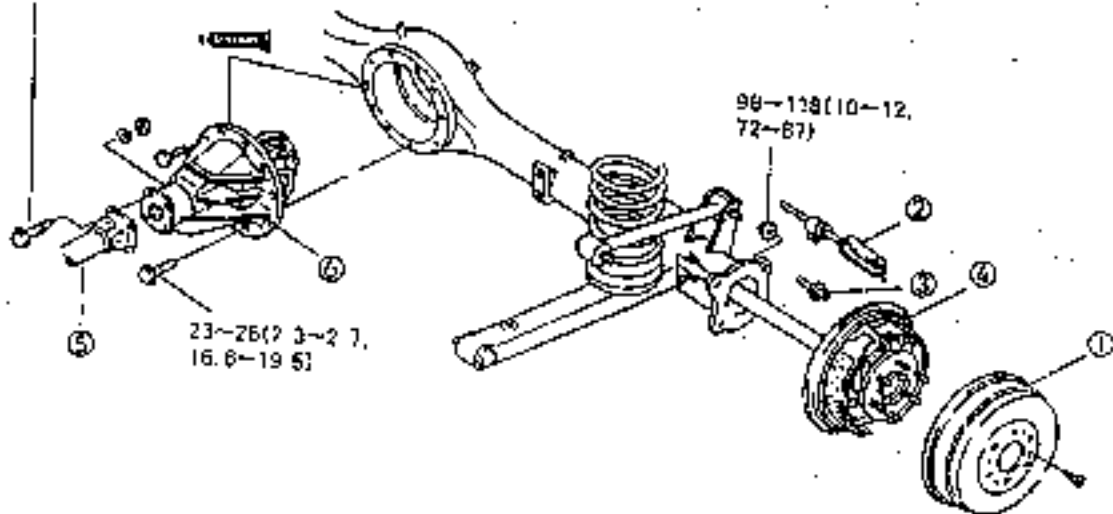

N-m/kg-m, (b-11)

AN9050012

- 1. Brake drum
- 2. Parking brake cable
- 3. Brake pipe

- 4. Backing plate & rear axle assembly
- 5. Propeller shaft
- 6. Differential assembly

# 50-10 FRONT AND REAR AXLE DIFFERENTIAL

## DISASSEMBLY/ASSEMBLY

1. Disassemble as shown in the figure, referring to the notes for disassembly.
2. Check every part and repair or replace, as required.
3. Assemble in the reverse order of disassembly, referring to the notes for assembly.

(12 seats)

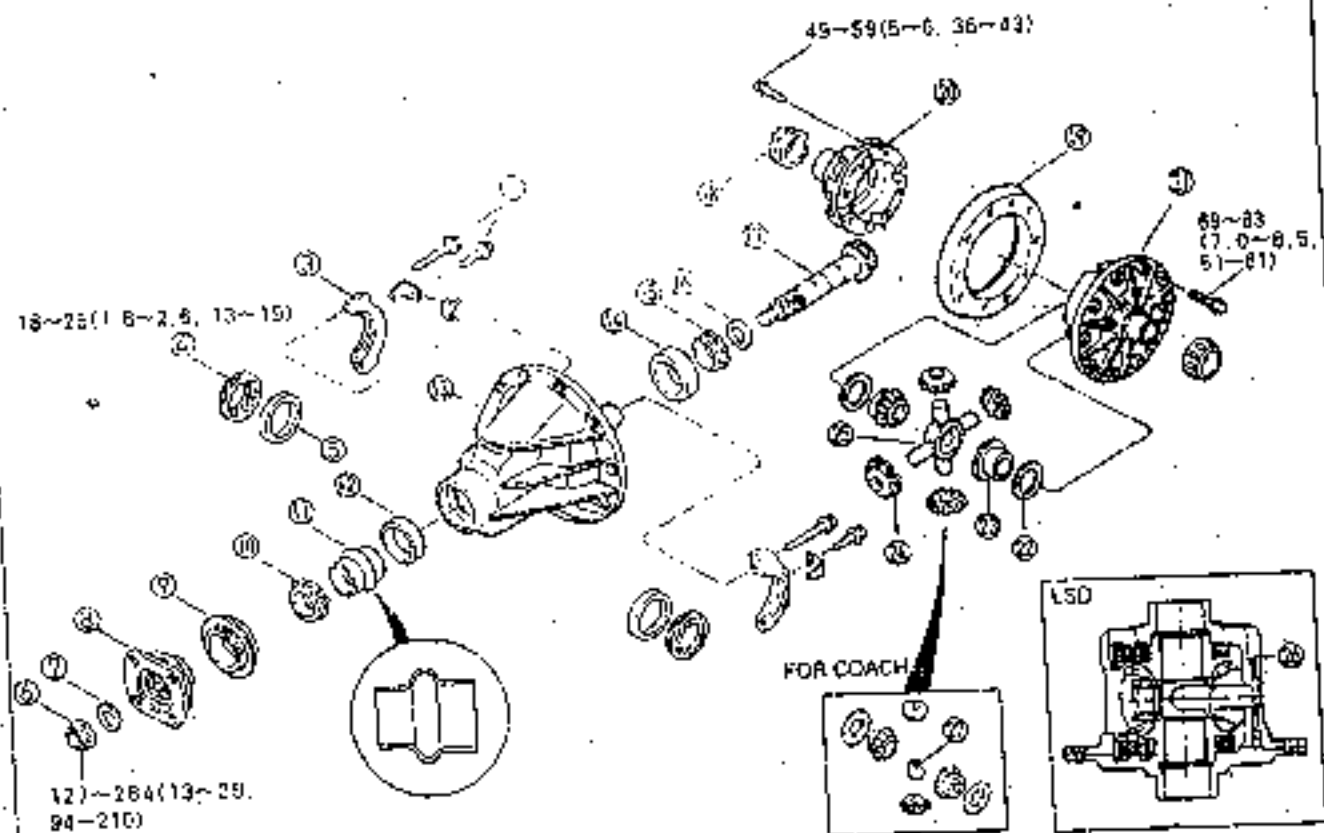

Nm(kg-m, lb-ft)

AN9050013

- |                       |                          |                     |
|-----------------------|--------------------------|---------------------|
| 1. Bolt               | 10. Bearing inner race   | 19. Ring gear       |
| 2. Lock plate         | 11. Collapsible spacer   | 20. Gear case cover |
| 3. Bearing cap        | 12. Bearing outer race   | 21. Gear case       |
| 4. Adjusting screw    | 13. Differential carrier | 22. Thrust washer   |
| 5. Bearing outer race | 14. Bearing outer race   | 23. Side gear       |
| 6. Lock nut           | 15. Bearing inner race   | 24. Pinion gear     |
| 7. Washer             | 16. Spacer               | 25. Spider          |
| 8. Companion flange   | 17. Drive pinion         | 26. LSD             |
| 9. Oil seal           | 18. Bearing inner race   | 27. Thrust block    |

(15 seats)

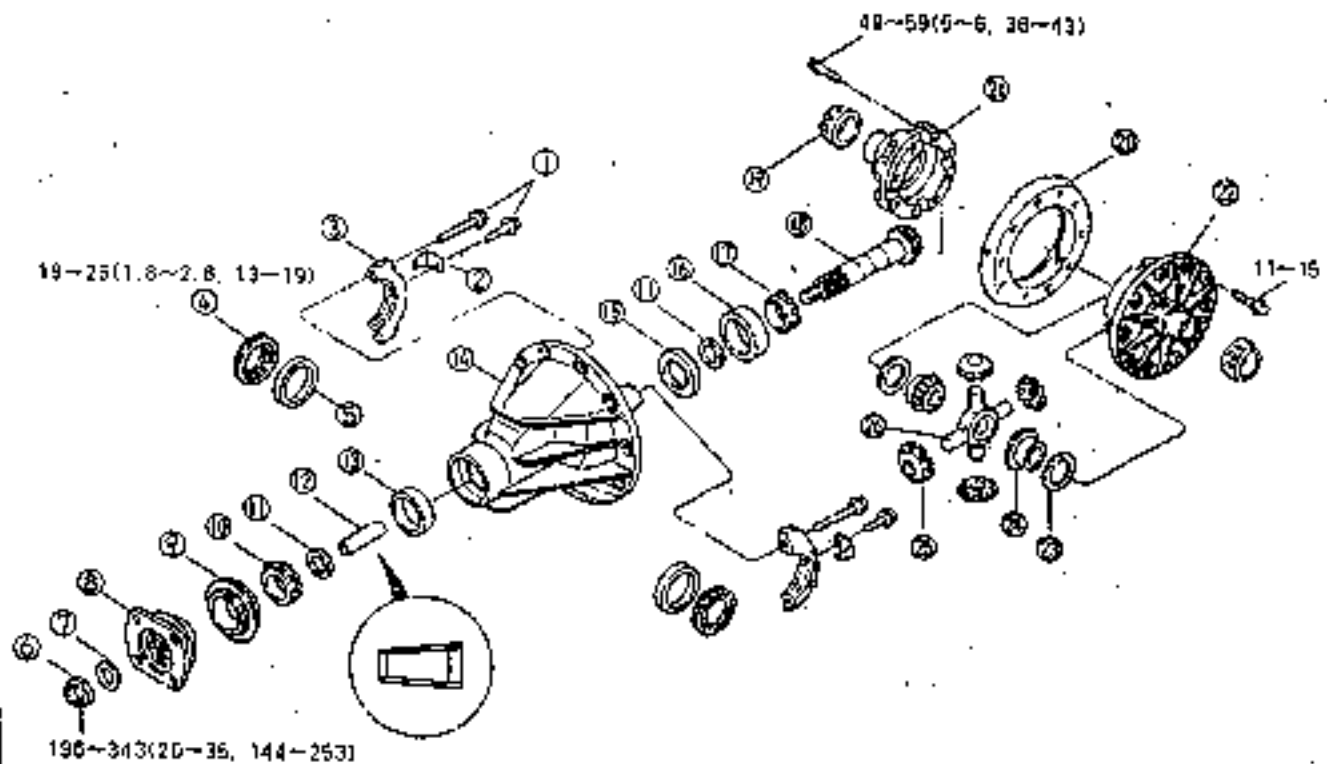

N·m(kg·m lb·ft)

J.NQ250U-33B

- |                       |                          |                        |
|-----------------------|--------------------------|------------------------|
| 1. Bolt               | 10. Bearing inner race   | 19. Bearing inner race |
| 2. Lock plate         | 11. Shim                 | 20. Ring gear          |
| 3. Bearing cap        | 12. Spacer               | 21. Gear case cover    |
| 4. Adjusting screw    | 13. Bearing outer race   | 22. Gear case          |
| 5. Bearing outer race | 14. Differential carrier | 23. Thrust washer      |
| 6. Lock nut           | 15. Shim                 | 24. Side gear          |
| 7. Washer             | 16. Bearing outer race   | 25. Pinion gear        |
| 8. Companion flange   | 17. Bearing inner race   | 26. Spider             |
| 9. Oil seal           | 18. Drive pinion         |                        |

## 50-12 FRONT AND REAR AXLE DIFFERENTIAL

### DISASSEMBLY NOTE

#### Differential carrier

1. Install differential gear assembly to SST.
2. Mark bearing cap and carrier for joining.

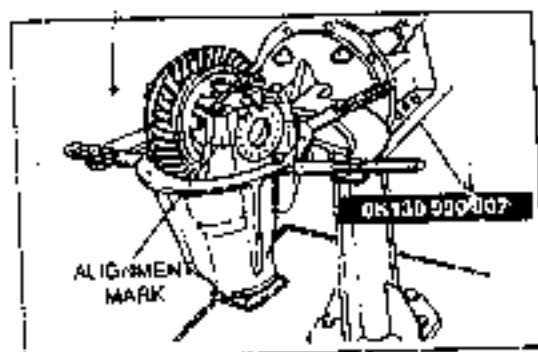

AN9050014

#### Companion flange

1. Remove lock nut, after holding companion flange with SST.

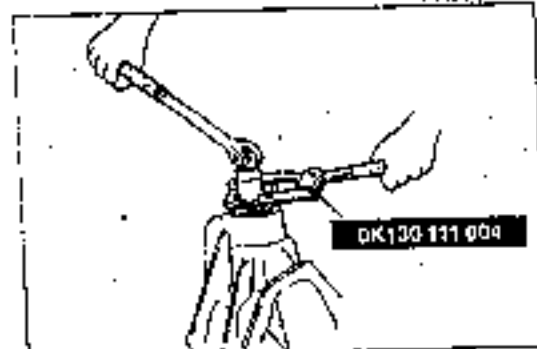

AN9050015

2. Remove companion flange using SST.



AN9050018

#### Rear bearing

Remove bearing using SST.

#### Note

- Use your hand for drive pinion not to drop.

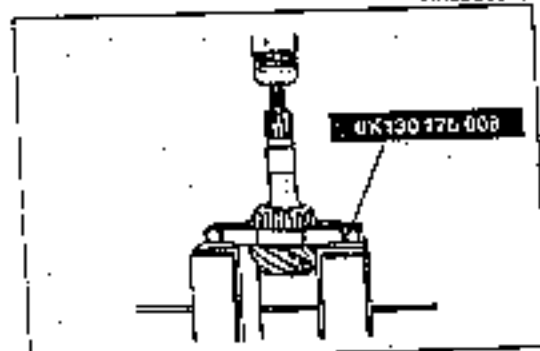

AN9050017

#### Side bearing

Remove side bearing from gear case using SST.

#### Note

- Make an alignment mark on bearing for reassembly.



AN9050016

**INSPECTION**

**Collapsible spacer : 12 seats**

At the time of differential assembly, replace collapsible spacer with new one.

Standard length : 54.8~56.09 mm(2.16~2.21 in)

**Assembly note**

**Adjustment of pinion height**

1. Assemble front bearing outer race using SST.
2. Assemble rear bearing outer race using SST. (12 seats)  
Assemble rear bearing outer race using SST. After adjusting to the differential carrier. (15 seats)
3. For assembly of pinion, use drive pinion model(0K993 270 A01), pinion height adjustment gauge body(0K993 270 A09) and gauge block(ht. 29 mm(1.102 in)).
4. Assemble spacer and rear bearing inner race to pinion model and fix it with O-ring. (12 seats)  
Assemble rear bearing inner race to pinion model and fix it with O-ring. (15 seats)

**Note**

- Use spacer disassembled.(12 seats)

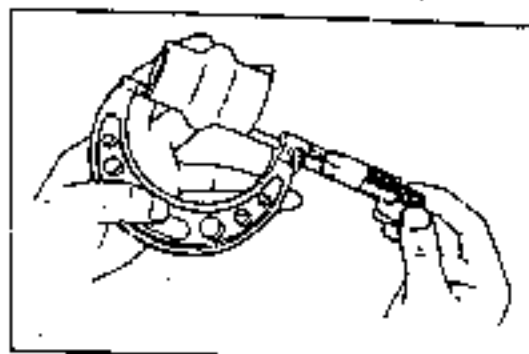

AN8050019

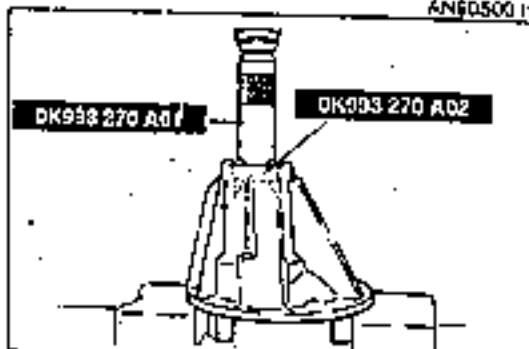

AN8050020

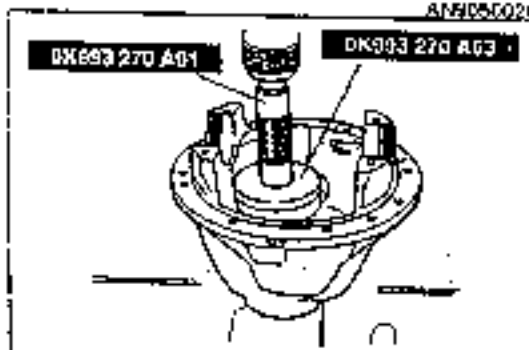

AN8050021

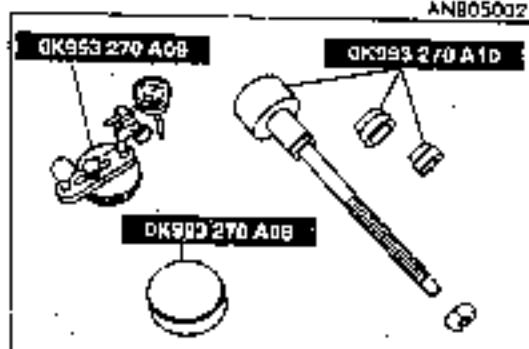

AN8050022

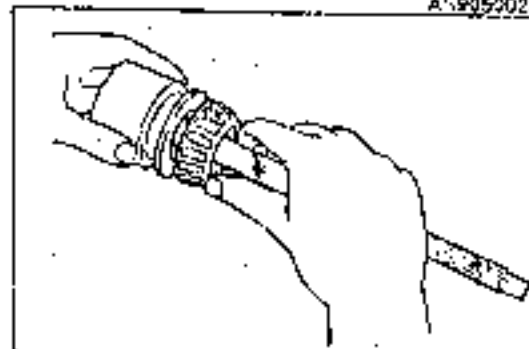

AN8050023



5. Install pinion model assembly to carrier.
6. Assemble front bearing, collar, companion flange washer, and lock nut.

**Note**

- Use washer and lock nut disassembled.

7. Tighten lock nut.

**Note**

- Tighten to the extent the companion flange can be screwed by hand.

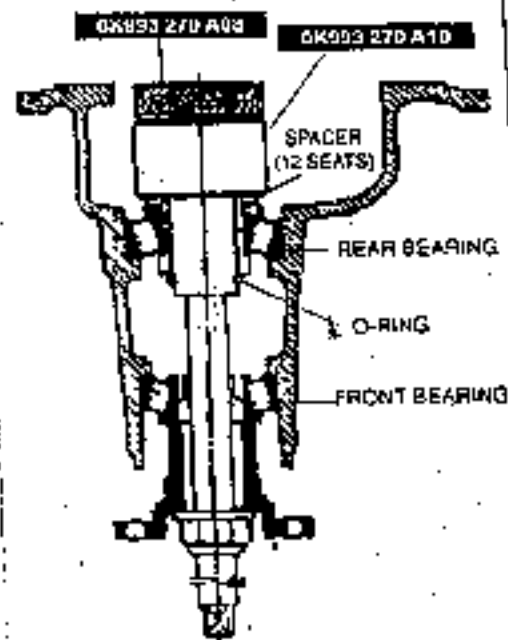

AN9050025

- B. Put pinion height adjusting gauge body at right angle and adjust it to 0.

9. Put pinion height adjusting gauge body and gauge block to the upper side of pinion model.
10. Dial gauge needle should be placed at the lowest part of side bearing.
11. Measure minimum positions of both sides (LH, RH).

12. Add both values and divide it by 2.

13. If the value of the above step 12 is not within specification, use new spacer adding the values to current spacer.(12 seats)

Standard clearance : -0.025 ~ 0.025 mm (-0.001 ~ 0.001 in)

mm(in)			
MARK	THICKNESS	MARK	THICKNESS
08	3.08(0.1212)	29	3.29(0.1295)
11	3.11(0.1224)	32	3.32(0.1307)
14	3.14(0.1236)	35	3.35(0.1318)
17	3.17(0.1248)	38	3.38(0.1330)
20	3.20(0.1259)	41	3.41(0.1342)
23	3.23(0.1271)	44	3.44(0.1354)
26	3.26(0.1283)	47	3.47(0.1365)

If the value of the above step 12 is not within specification, use new shim adding the values to current shim.(15 seats)

PARTS NUMBER	THICKNESS
K89963 - 6919	0.11(0.0039)
K89963 - 6912	0.125(0.0049)
K89963 - 6917	0.15(0.0059)

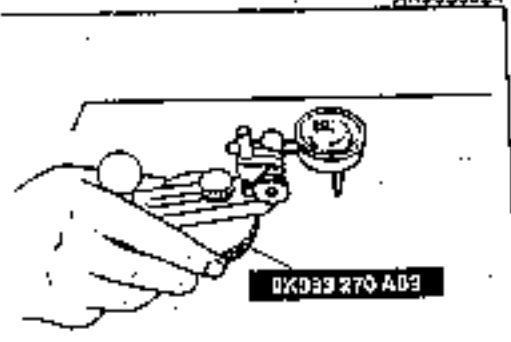

AN9050025

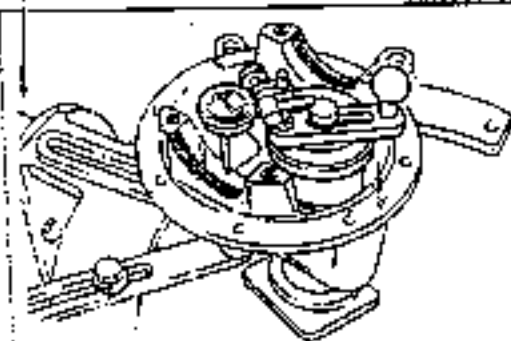

AN9050026

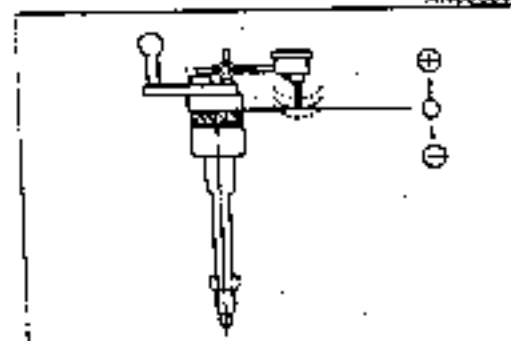

AN9050027

**Adjustment of drive pinion preload(12 seats)**

1. Install spacer.
2. Push rear bearing in using SST.

**Note**

- Keep pressuring until the sudden increase of necessary power.
- Place the spacer for adjusting pinion height, ensuring exact direction of installation.

3. Install collapsible spacer.
4. Push front bearing in using SST.
5. Install drive pinion assembly.
6. Install companion flange and tighten lock nut.

**Tightening torque :**

127~284 N·m(13~29 kg·m, 94~210 lb-ft)

**Note**

- Do not install oil seal.

7. Turn companion flange by hand so that bearing be put at the right place.
8. Measure preload of drive pinion. If the result is not within specification, use new collapsible spacer and measure again.

Preload : 127~176 N·m(13~18 kg·cm, 94~130 lb-ft)

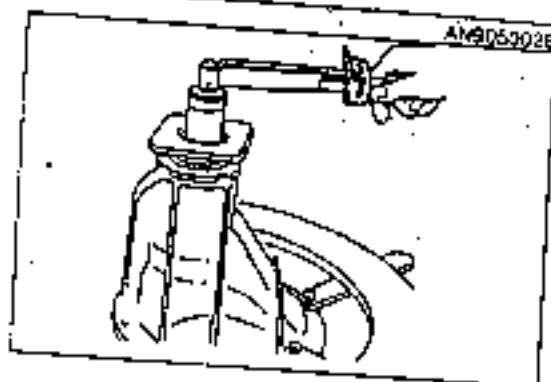
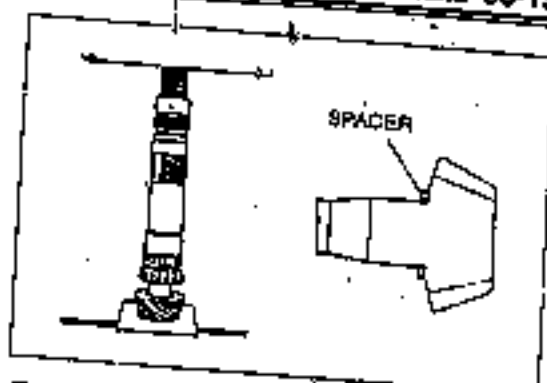

AN905002B

AN905002B

**Adjustment of drive pinion preload(15 seats)**

1. Push rear bearing in using SST to the drive pinion.

**Note**

- Keep pressuring until the sudden increase of necessary power.
- Place the shim for adjusting pinion height, ensuring exact direction of installation.

2. Install spacer.
3. Push the front bearing in using SST after installing the shim.
4. Install drive pinion assembly.
5. Install companion flange and tighten lock nut.

**Tightening torque :**

196~343 N·m(20~35 kg·m, 144~253 lb-ft)

**Note**

- Do not install oil seal.

6. Turn companion flange by hand so that bearing be put at the right place.
7. Measure preload of drive pinion. If the result is not within specification, adjust it with the shim and measure again.

Preload : 147~196 N·m(15~20 kg·cm, 108~144 lb-ft)

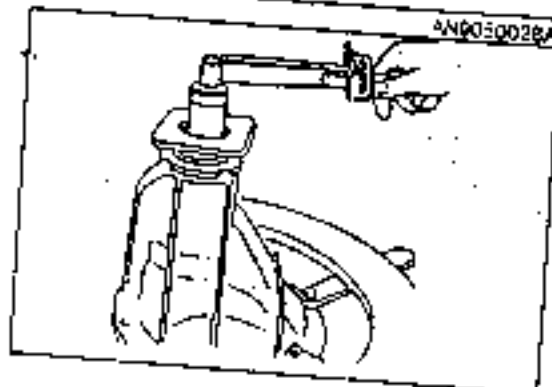
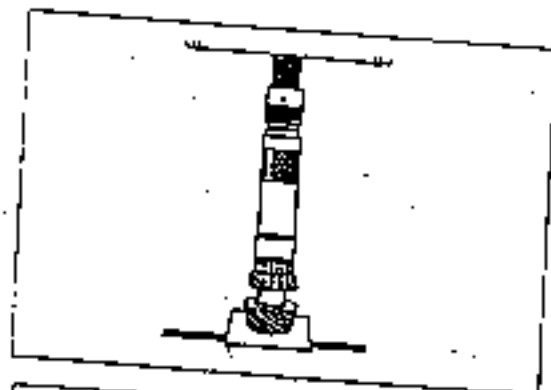

AN905002BA

AN905002B

**Backlash adjustment**

1. Insert bearing inner race using SST.

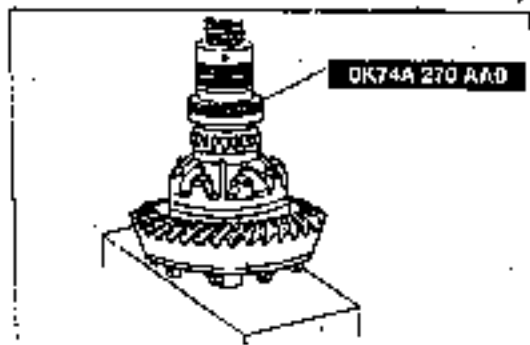

AN6050030

2. Install differential gear assembly to carrier
3. Pay attention to the marks of the adjuster for its right positioning.
4. Make sure that the mark of the cap identifies with one of the carrier at the time of installation of differential bearing cap.

Tightening torque :

72-106 N·m(7.4-10.9 kg-m, 53-78 lb-ft)

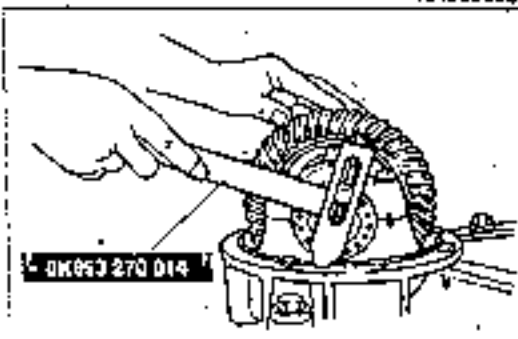

AN6050031

5. Mark ring gear every 90 degree and install dial indicator to carrier in the position that the indicator needle makes a right angle with side surfaces of ring gear.
6. Turn both bearing adjusters together using SST until the backlash reaches 0.09-0.11 mm(0.0035-0.0043 in).

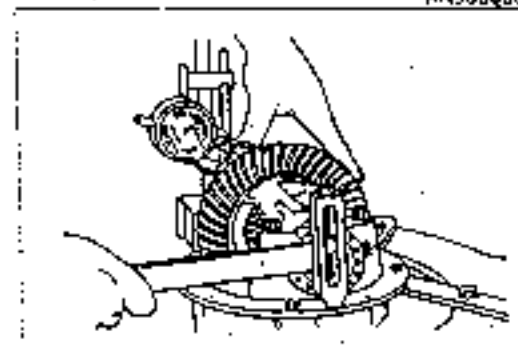

AN6050032

7. Check backlash from three different marks. Be sure that the minimum backlash is not less than 0.05 mm and the difference between the minimum and maximum values does not exceed 0.07 mm(0.13 in).

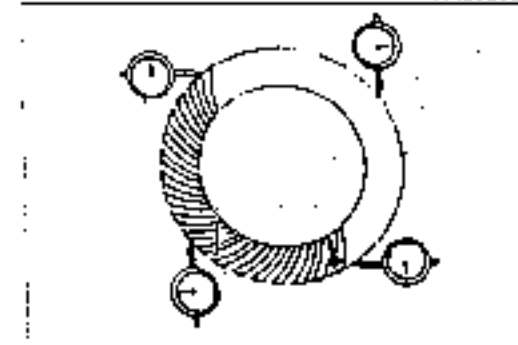

AN6050033

8. Tighten adjuster until the distance between the pilots on bearing cap reaches following values.

Limit : 204.428-204.5 mm(8.048-8.051 in)(12 seats)  
219.428-219.5 mm(8.638-8.641 in)(15 seats)

**Note**

- Be careful adjustment of differential bearing preload not to effect the backlash of drive pinion and ring gear.

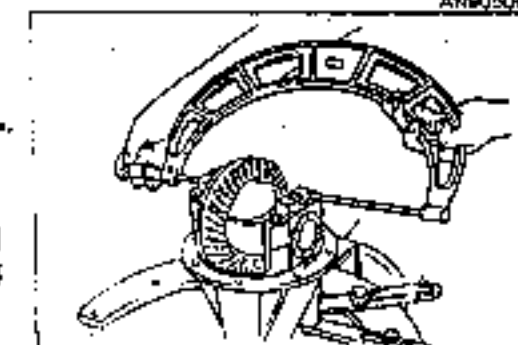

AN6050034

Ring gear-to-pinion gear contact adjustment

1. Coat both surfaces of 6-8 ring gear teeth with prussian blue or white grease.
2. Rotate the marked ring gear teeth back and forth past the pinion.
3. If the ring gear pinion marks are not near the center of the ring gear teeth, disassemble, and adjust pinion in or out.

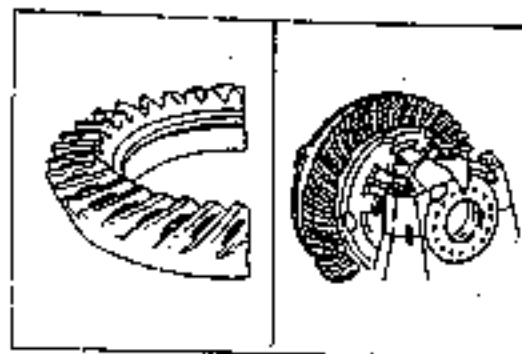

AN905003

- (1) Toe and flank contact marks  
Use thinner pinion spacer to move pinion out.

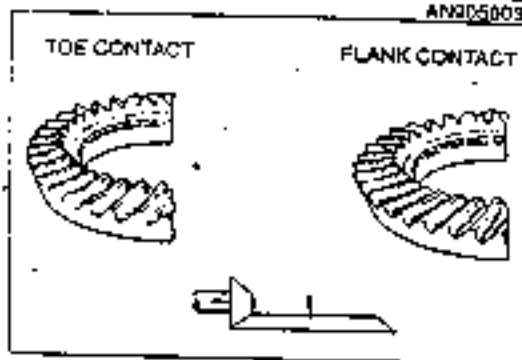

AN905003

- (2) Heel and face contact marks  
Use thicker pinion spacer to move pinion in.

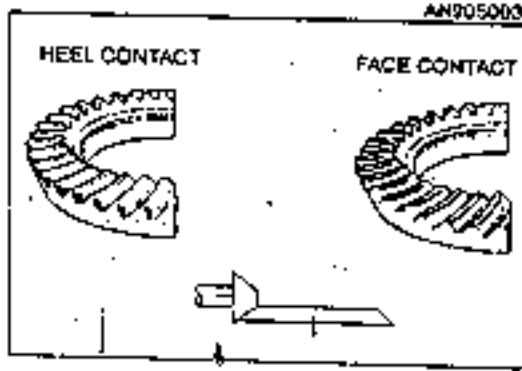



AN905003

## SPECIFICATIONS







Items		ATX	MTX
<b>Front axle</b>			
Bearing preload(without oil seal)		N·m(kg-m, lb-ft) 39-78(4~8, 29-58)	
<b>Rear axle</b>			
Type		Semi float	
Bearing axial play		mm(in) 0.05(0.002)	
<b>Differential</b>			
Reduction gear		Hypoid gear	
Differential gear		Straight bevel gear	
Final gear ratio		4.444	4.222(12 seats), 4.111(15 seats)
Oil	Grade	API GL-5	
	Viscosity	Above -18°C(+4°F)	SAE 90
		Below -18°C	SAE 80W
	Amount	l (qt)	1.3(1.373)(12 seats), 1.6(1.68)(15 seats)





## SPECIAL TOOLS

## FRONT AXLE

DK130 263 021 Ball joint puller 	For disassembly of ball joint	DK670 321 019 Ball joint puller 	For disassembly of ball joint
--	-------------------------------	---	-------------------------------

## DIFFERENTIAL

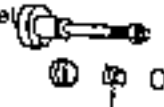
DK670 900 A40 Bearing installer set 	For disassembly of side bearing	DK130 175 008 Pan pulley boss puller 	For disassembly of front, rear bearing
DK130 175 A13 Grease 	For assembly of side bearing	DK993 370 A01 Handle 	For assembly of outer race
DK993 270 A04 Attachment (272) 	For(Front bearing) outer race assembly	DK993 260 A03 Attachment (262) 	For(Rear bearing) outer race assembly

<p>OK74A 270 A40</p> <p>Attachment</p> 	<p>For side bearing assembly</p>	<p>OK130 111 004</p> <p>Coupling flange holder disassembly</p> 	<p>For lock nut</p>
<p>OK993 270 A08</p> <p>Drive pinion</p> 	<p>For adjusting height of drive pinion</p>	<p>OK 993 270 A10</p> <p>Drive pinion model</p> 	<p>For adjusting height of</p>
<p>OK993 270 A08</p> <p>Gauge block</p> 	<p>For adjusting height of drive pinion</p>	<p>OK993 270 014</p> <p>Adjusting nut wrench</p> 	<p>For adjusting screw disassembly</p>

REAR AXLE

<p>OK74A 262 001</p> <p>Rear axle shaft bearing puller</p> 	<p>For rear axle shaft bearing disassembly</p>
---	--

# STEERING

51

MANUAL STEERING .....	51- 3
POWER STEERING .....	51- 8
POWER STEERING OIL PUMP .....	51-13
SPECIAL TOOLS .....	51-14
SPECIFICATIONS .....	51-14
STEERING GEAR AND LINKAGE .....	51-12

MANUAL STEERING

STRUCTURAL VIEW

PINION GEAR

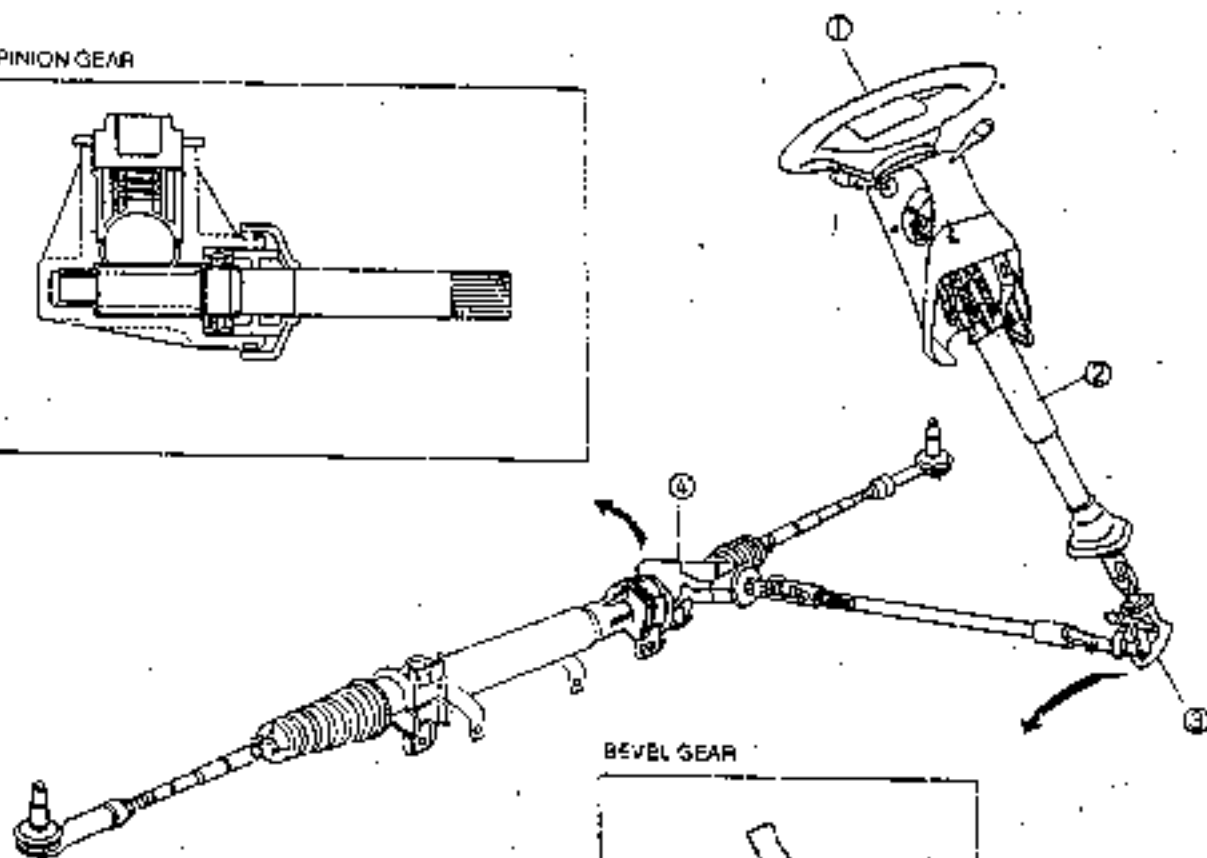
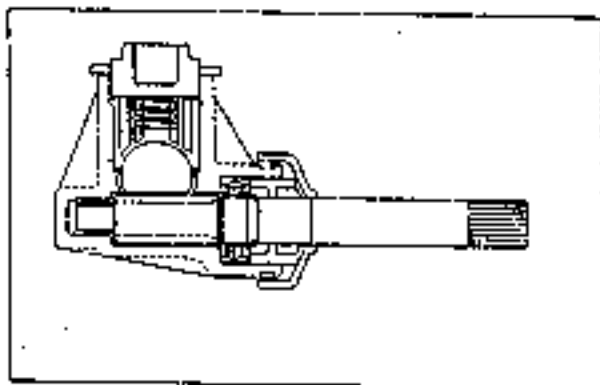

BEVEL GEAR

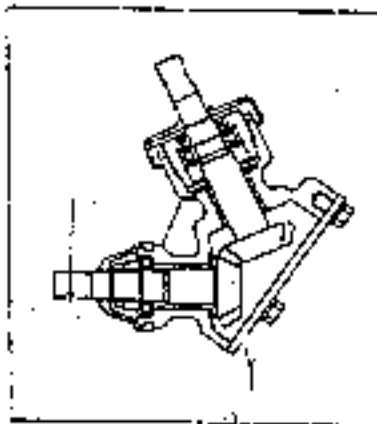

- 1. Steering wheel
- 2. Steering shaft

- 3. Bevel gear
- 4. Steering gear



## TROUBLESHOOTING GUIDE

Problem	Possible cause	Action
Steering heavy	Improper tire air pressure Incorrect adjustment of preload of bevel gear Incorrect adjustment of preload of pinion Incorrect adjustment of wheel alignment Unsmooth operation of linkage ball joints Unnecessary contact during steering shaft turning	Adjust Adjust Adjust Adjust Replace Repair/replace
Steering wheels don't return properly	Tires not properly inflated Improper wheel alignment Unsmooth operation of linkage ball joints Unnecessary contact during steering shaft turning Incorrect adjustment of preload of bevel gear and pinion	Adjust Adjust Replace Repair/replace Adjust
Erratic steering	Unnecessary contact during steering shaft turning and loose ball Unsmooth operation of steering linkage Improper adjustment of preload of bevel gear	Repair/retighten Repair/replace Adjust
Steering wheel pulls to one side	Improper tire air pressure Incorrect adjustment of wheel bearing preload and worn wheel bearing Misalignment of wheel Poor steering gear	Replace Adjust, Replace Adjust Replace
Abnormal noise	Steering linkage loose or worn Worn steering joints Incorrect adjustment of backlash of gear box	Replace, Tighten Replace Adjust
Leaks of bevel gear grease	Damaged gasket Damaged dust boot Damaged lip seal	Replace Replace Replace

**INSPECTION AND ADJUSTMENTS**

**Steering wheel play**

1. Place the front wheels in the straight ahead position and check if the play meets the standard by turning the steering wheel from side to side.

Play : 0-40 mm(0-1.57 in)

**Note**

- When the standard is not met, check if each steering joint is worn or too much backlash of steering gear.

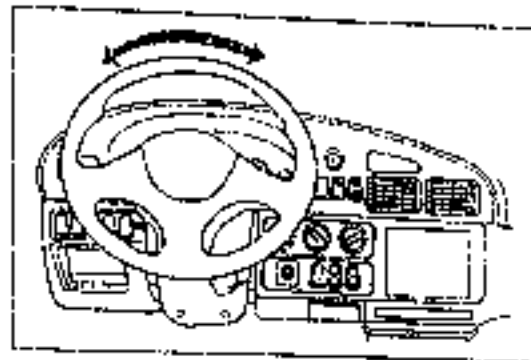

AN9051302

**Steering wheel force**

1. With the vehicle on the ground level, place the front wheels in the straight ahead position.
2. Attach a pull scale to the outer end of the steering wheel spoke and pull the spring scale to rotate the wheel.

Required force : 225 N(23 kg, 51 lb)

**Note**

- When checking, turn wheel more than 5 times to have correct measurement.
3. Check the followings if the results of the checking do not meet the standard.  
Pinion torques, ball joints torques, improper joints

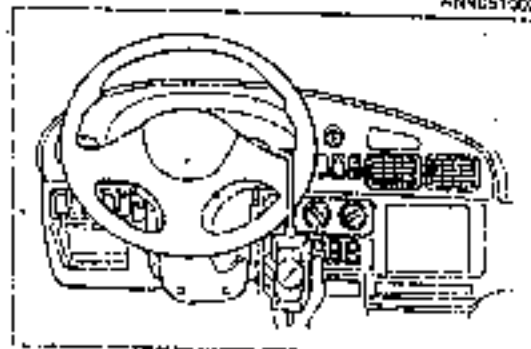

AN9051303

**Steering wheel looseness, rattle**

1. Attempt to move wheel axially in and out ①, left & right side ②, ③ and check for worn column bearings, clunking of steering shaft joints, loose steering and column couplers.

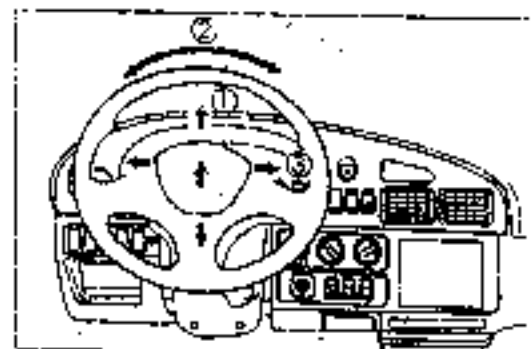

AN9051304

## BOOT

### Replacement

1. Remove tire and wheel.
2. Remove in the numerical order as shown in the figure.
3. Install in the reverse order of removal.
4. Check wheel alignment after installation.

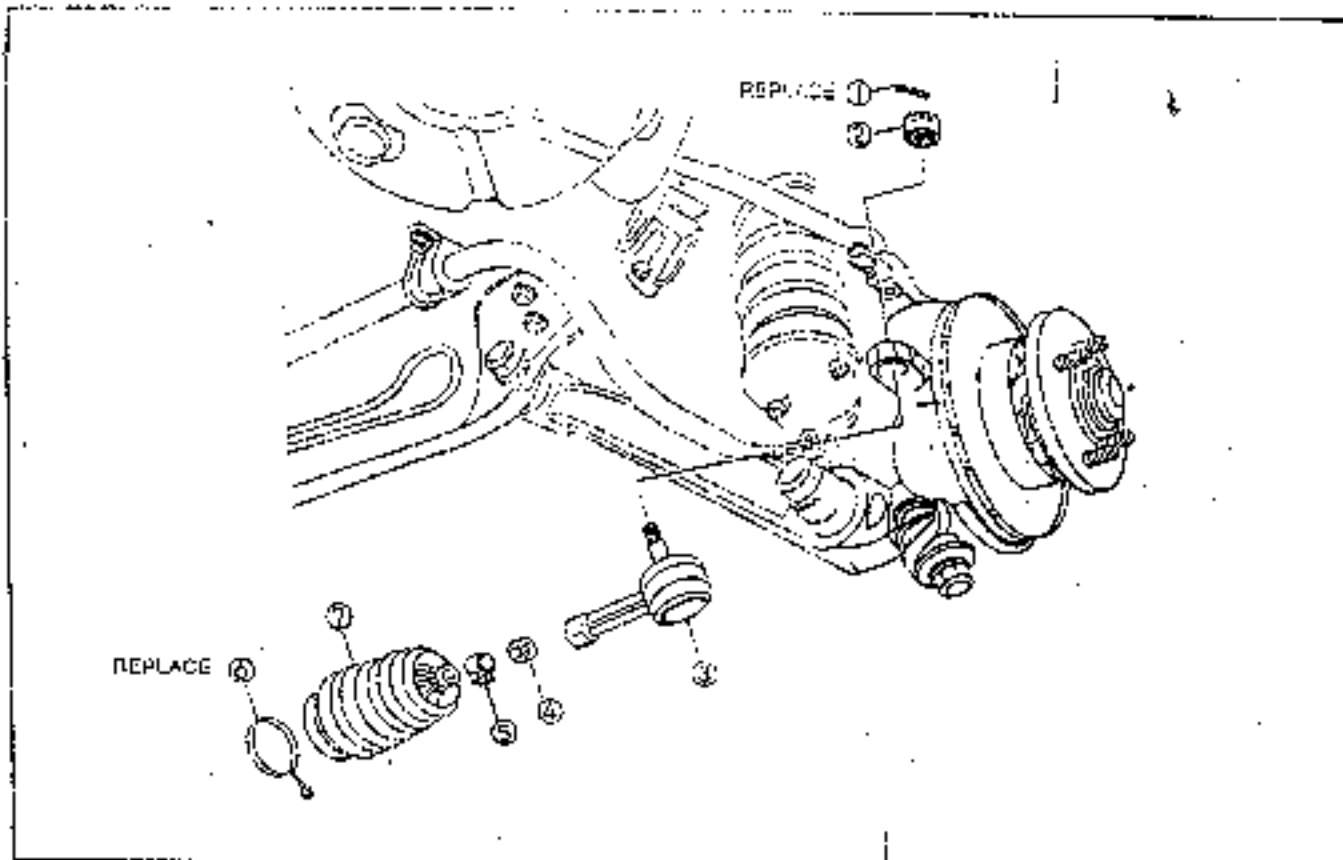

AN9051005

1. Cotter pin
2. Nut
3. Tie-rod end
4. Lock nut

5. Boot band
6. Boot wire
7. Boot

### Removal

1. Remove cotter pin from tie-rod end stud and loosen until the nut reaches very end of stud.

#### Caution

- Tighten screw temporarily ensuring its thread not to be damaged.

2. Separate tie-rod end from steering knuckle using SST.

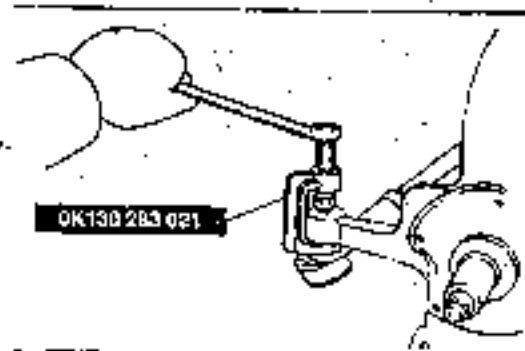

AND050003

**STEERING SHAFT ASSEMBLY****Removal and Installation**

1. Remove the negative terminal of the battery.
2. Position vehicle straight ahead.
3. Remove in the numerical order as shown in the figure.
4. Install in the reverse order of removal.

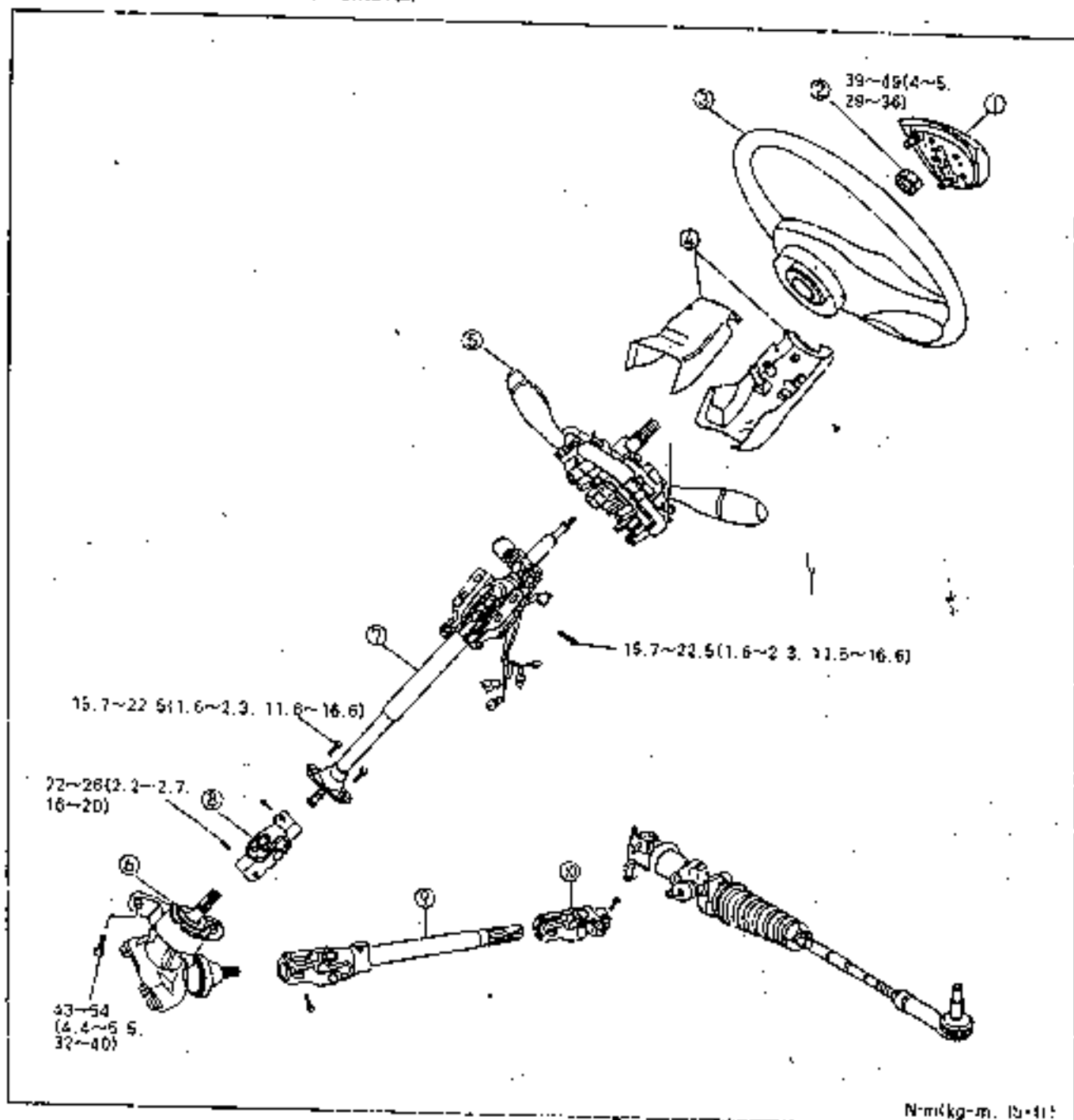

N-m/kg-m. 15-411

AF9051000A

- |                       |                       |
|-----------------------|-----------------------|
| 1. Horn cap           | 6. Bevel gear         |
| 2. Lock nut           | 7. Steering shaft     |
| 3. Steering wheel     | 8. Universal joint    |
| 4. Column cover       | 9. Intermediate shaft |
| 5. Combination switch | 10. Universal joint   |

POWER STEERING

STRUCTURAL VIEW

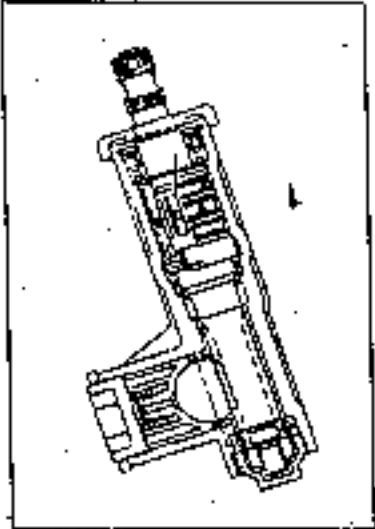
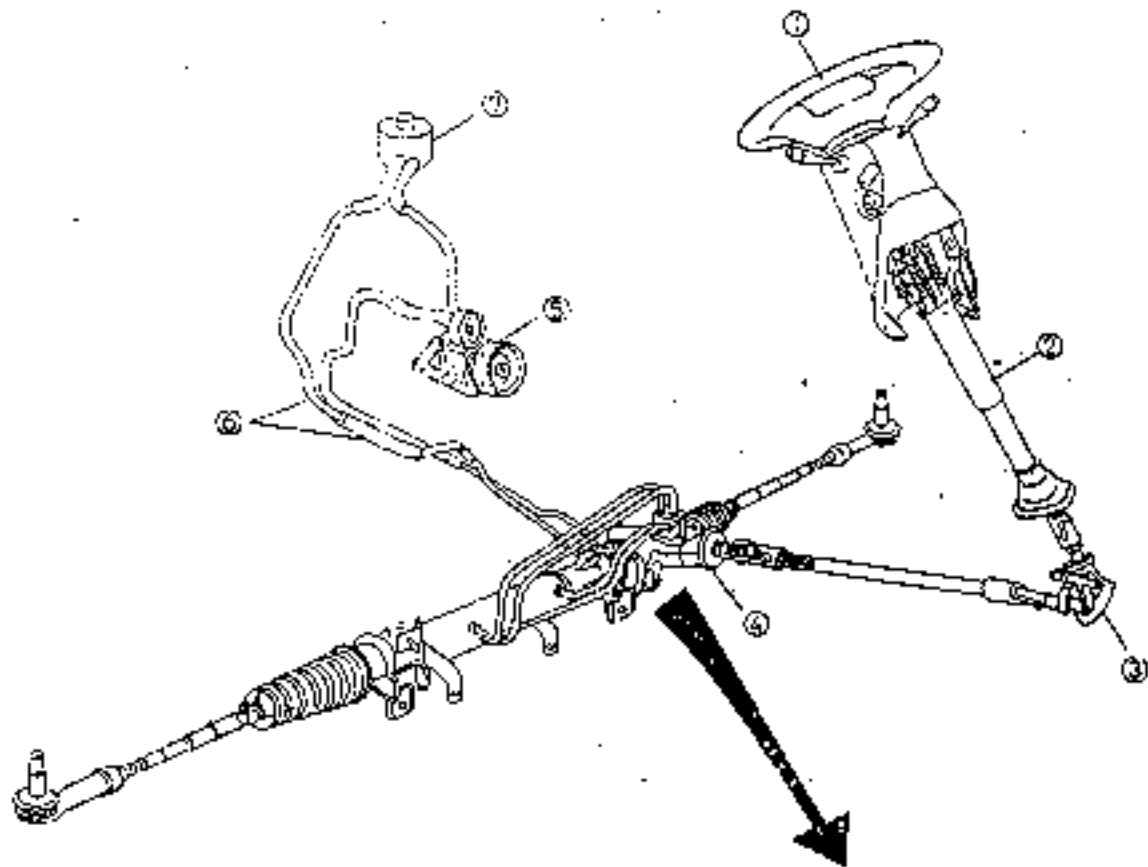

- 1. Steering wheel
- 2. Steering shaft
- 3. Bowl gear
- 4. Steering gear

- 5. Oil pump
- 6. Oil pipe & hose
- 7. Reservoir

**TROUBLESHOOTING GUIDE**

Problem	Possible cause	Action
Steering heavy	Power steering belt loose or damaged Leak of power steering fluid or air in system Hose kinked or twisted Pipe kinked Power steering fluid leak Low pressure of fluid Tires not properly inflated Improper adjustment of wheel alignment Poor operation of steering gear linkage Steering column touching other parts	Adjust or replace Add fluid or bleed air Replace Replace Repair or replace Repair or replace Adjust Adjust Repair or replace Repair or replace
Steering wheels don't return properly	Tires not properly inflated Improper adjustment of wheel alignment Poor operation of steering gear linkage Steering gear out of order	Adjust Adjust Repair or replace Replace
Erratic steering	Loose power steering belt Steering column out of order or loose bolts Unsmooth operation of steering linkage Defective steering gear	Adjust Repair or tighten Repair or replace Replace
Steering wheel pulls to one side	Tires not properly inflated Incorrect adjustment of preload or worn wheel bearings Improper adjustment of wheel alignment Steering gear out of order	Adjust Adjust or replace Adjust Replace
Power steering fluid leaks	Trouble at hose couplings Hose damaged or clogged Power steering fluid reservoir damaged Overflow Power steering pump out of order Steering gear malfunction	Repair or replace Replace Replace Air bleed, Adjust fluid amount Replace Replace
Noise	Power steering pump out of order Loose steering gear Loose power steering pump bracket Loose power steering pump pulley nuts Bell loose or excessive lugs Air in system Steering gear out of order Power steering pump out of order Steering column or pressure hose touching other parts Steering linkage loose	Tighten Tighten Tighten Tighten Adjust Air bleed Replace Replace Repair or replace Adjust or replace

**POWER STEERING PRESSURE TEST**

**Caution**

- Verify that power steering system gauge valve is opened for the system to operate.
- Do not leave steering wheel turned longer than 15 seconds.

1. Remove high pressure pipe and install power steering system gauge using adapter.
2. Insert a thermometer into power steering fluid tank.
3. Perform air bleeding as following procedures.
  - 1) Check fluid level in the reservoir, and add fluid as necessary.
  - 2) Raise and support the front of the vehicle.
  - 3) Turn steering wheel to the extreme left and right 10 times.
  - 4) Check fluid level again, and add fluid if reduced.
  - 5) Until fluid reaches and remains at the proper level, repeat steps 3) and 4).
  - 6) Start engine and let idle.
  - 7) Turn steering wheel to the extreme left and right positions 10 times.
  - 8) Verify that any bubble is created. As bubbles indicate air in system, repeat steps 2)~7).

**Caution**

- Check air leaks in system if bubbling keep taking place.

4. Check temperature of power steering fluid. If the temperature is not in the range of 50°C-60°C (92-110°F), turn steering wheel to the left and right positions until the specification is obtained.

**Caution**

- Close valve for a second to read the pressure.
- Do not leave it closed for longer than 15 seconds.

5. Close power steering system gauge valve, and measure power steering pump relief pressure increasing engine rpm to 1000-1500.
6. Increase engine rpm to 1000-1500 with power steering system gauge valve opened.
7. Read pressure with steering wheel in the extreme right or left.
8. Separate adapter from power steering system gauge. Reconnect high pressure line and tighten to 16-24 N·m (1.3-2.4 kg·m, 12-17 lb-ft).
9. Remove thermometer and bleed air as described in the step 3).

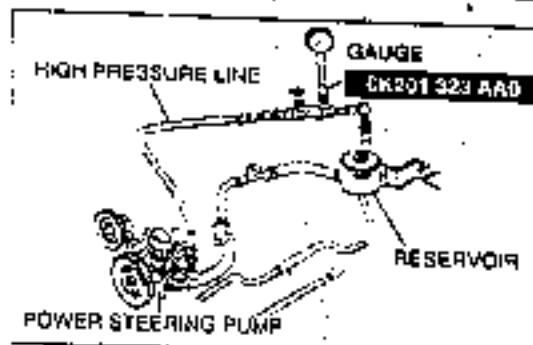

IN9051008

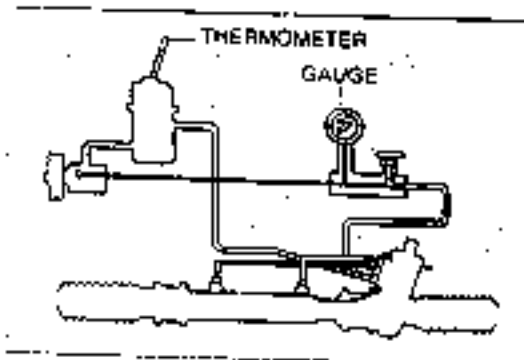

BSX031046-1

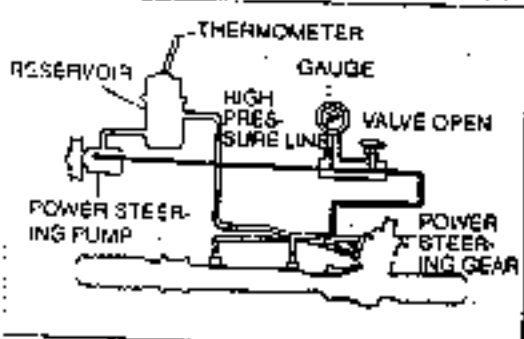

BSX051048-2

**Steering wheel force**

1. Put thermometer into power steering fluid tank.

**Caution**

- Do not leave steering wheel turned for more than 15 seconds at a time.

2. Start engine and turn steering wheel in the right and left positions several times until fluid temperature reaches 50°C-60°C (92-110°F).
3. Place vehicle on ground level with steering wheel in the straight ahead direction.
4. Attach a pull scale to the outer end of the steering wheel spoke and measure necessary force to rotate the wheel. The operational force should be less than 29.4 N (3.0 kg, 6.6 lb).

**Caution**

- For accurate measure, pull the pull scale in a direction perpendicular to the radius of the steering wheel.

5. If the force exceeds specification, inspect for lack or leakage of steering fluid, air in system, power steering pump pressure, steering gear pressure and tire inflation.
6. Remove thermometer.

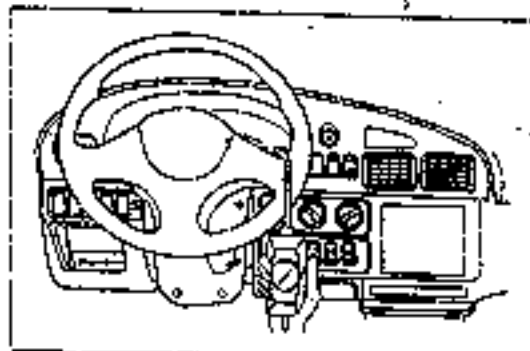
**Power steering fluid check**

1. Check the fluid level of the power steering at the reserve tank. Add fluid so that indicator comes between Max and Min.

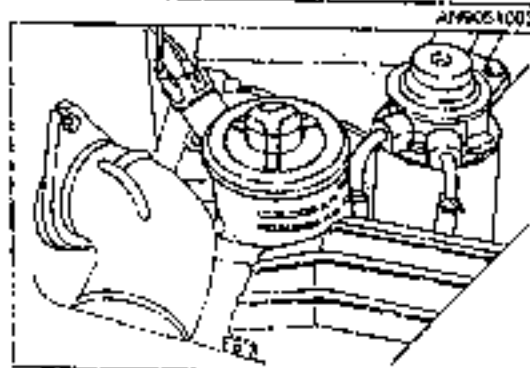

2. Let the engine run and make steering wheel 10 turns in the extreme right and left positions until normal operational temperature.
3. Stop engine with steering wheel in the straight ahead position.
4. Check steering fluid and add fluid so that indicator comes between Max and Min.

**Air bleeding**

1. Check the fluid level of the power steering.
2. Raise and support the front of the vehicle.
3. Turn steering wheel in the extreme left and right positions several times with engine off.
4. Check the fluid level again and add fluid as required.
5. Repeat the step 2 and 3 until fluid reaches and remains at the proper level.
6. Start the engine and let run at idle speed.
7. Turn steering wheel in the extreme right and left positions several times.
8. Check the power steering fluid at the reserve tank. There should be no foam in the fluid.
9. Add fluid if necessary, and repeat the step 7 and 8.

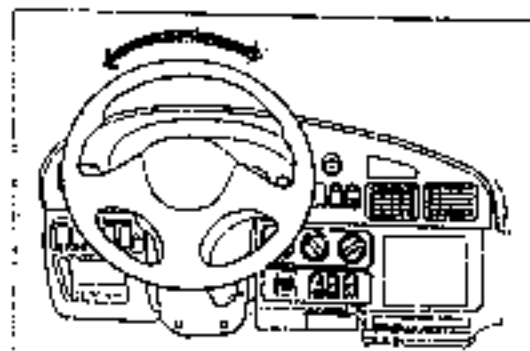



## STEERING GEAR AND LINKAGE

## REMOVAL AND INSTALLATION

1. Loosen wheel nut.
2. Raise and support the front part of vehicle with jack stands.
3. Remove tires.
4. Remove in the numerical order as shown in the figure for next procedure.
5. Install in the reverse of order removal.
6. After installation, bleed air from steering system and adjust toe-in as required.

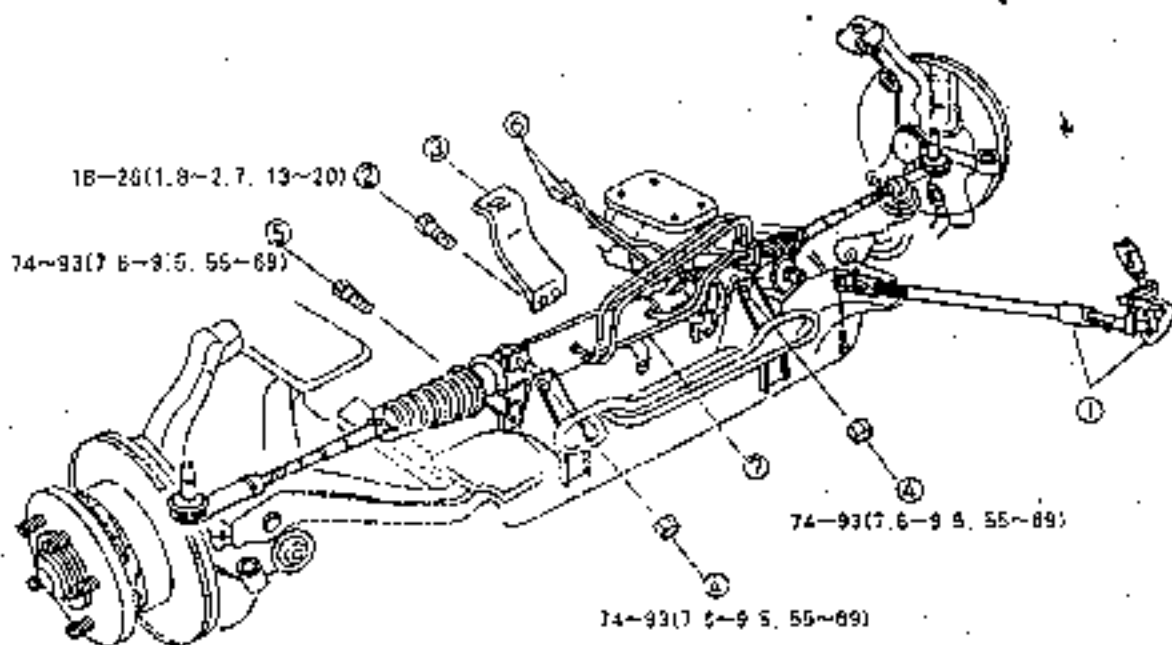

7m(kg-m, 1b-ft)

AN9051010

1. Bevel gear and intermediate shaft
2. Bolt
3. Bracket
4. Nut
5. Bolt

6. Return pipe and pressure pipe
7. Steering gear and linkage

## POWER STEERING OIL PUMP

### REMOVAL AND INSTALLATION

1. Remove in the numerical order as shown in the figure.

#### Caution

- When disconnecting pressure pipe and return hose, prepare a suitable container to catch power steering fluid as it drains.
2. Install in the reverse order of removal.
  3. After installation, following should be done.
    - 1) Adjust belt.
    - 2) Add power steering fluid and bleed air.
    - 3) Inspect for fluid leak at connecting point of oil pump and hose pipe.

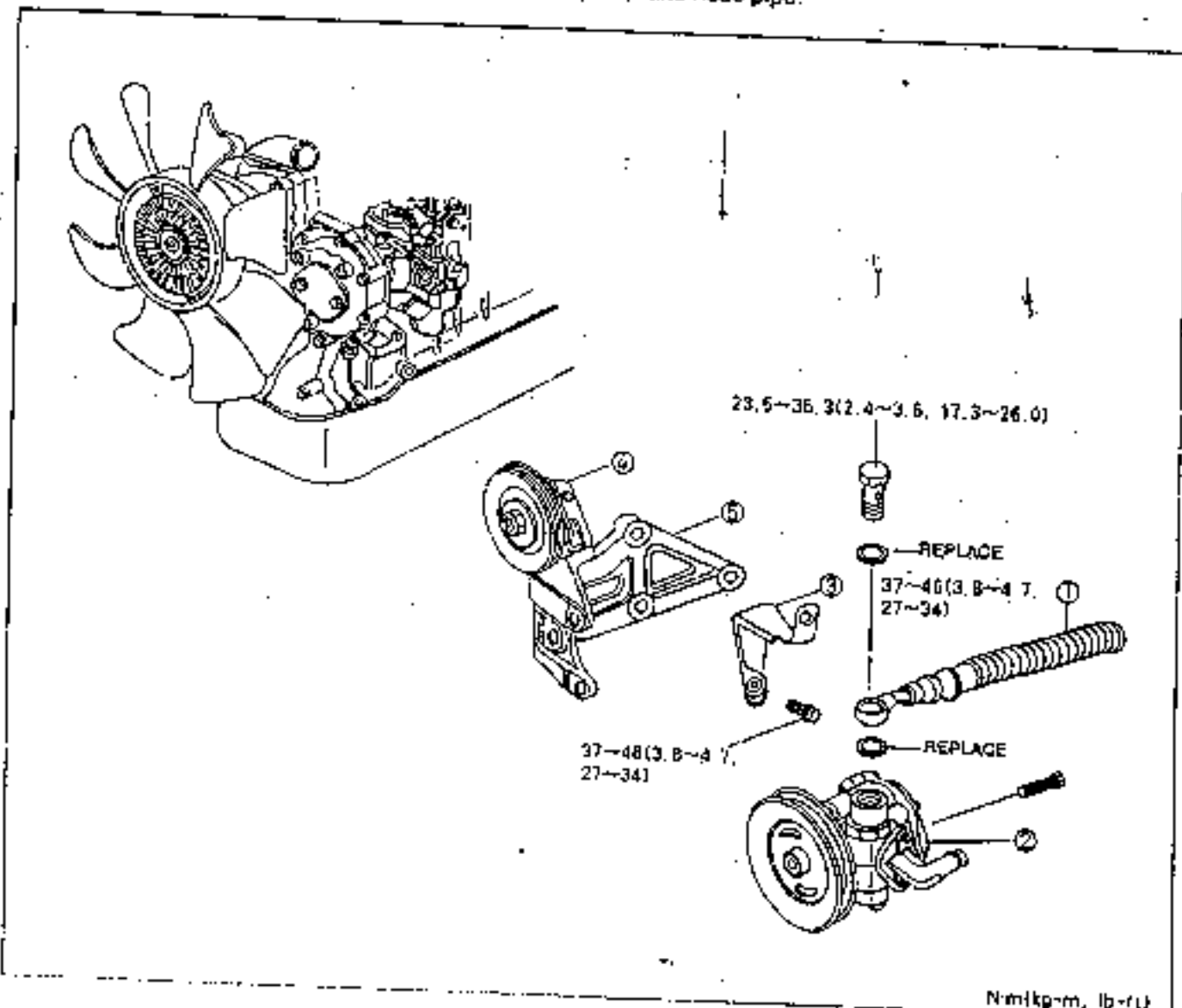

1. Pressure hose
2. Oil pump assembly
3. Bracket

4. Tensioner and bracket
5. Oil pump bracket

## SPECIFICATIONS

Items		Manual steering	Power steering
Steering wheel	Outer diameter mm(in)	390(15.4)	
	Turns lock to lock 12 seals(15 seals)	4.0(4.87)	4.0(4.19)
Steering shaft & joints	Type	Collapsible	
	Joints type	Universal joints	
	Tilt stroke	$\pm 7.7^\circ$	
Steering gear & linkage	Type	Rack & pinion	
	Gear ratio	-	
	Power assist	-	Engine speed sensing type
	Rack stroke	164	
Bevel gear	Gear ratio	1.125	
	Teeth	Input : 18 Output : 18	
	Maximum steering angle	33.80°	
Oil	Capacity	1.07(1.13)	
	Type	PSF-III	

## SPECIAL TOOLS

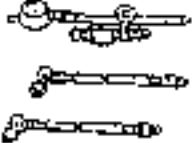
OK130 283 021 Puller, ball joint		For tie rod end disassembly and assembly	OK201 323 AA0 Gauge set		For measuring oil seal
-------------------------------------	---	--	----------------------------	---	------------------------

# BRAKE SYSTEM

52

BRAKE PEDAL .....	52- 8
FRONT DISC BRAKE .....	52- 9
LOAD SENSING PROPORTIONING VALVES(LSPV) .....	52- 8
MASTER CYLINDER .....	52- 7
ON-VEHICLE INSPECTION .....	52- 5
OUTLINE .....	52- 3
PARKING BRAKE .....	52-11
REAR DRUM BRAKE .....	52-10
SPECIAL TOOLS .....	52-12
SPECIFICATIONS .....	52-12
TROUBLESHOOTING GUIDE .....	52- 4

OUTLINE

STRUCTURAL VIEW

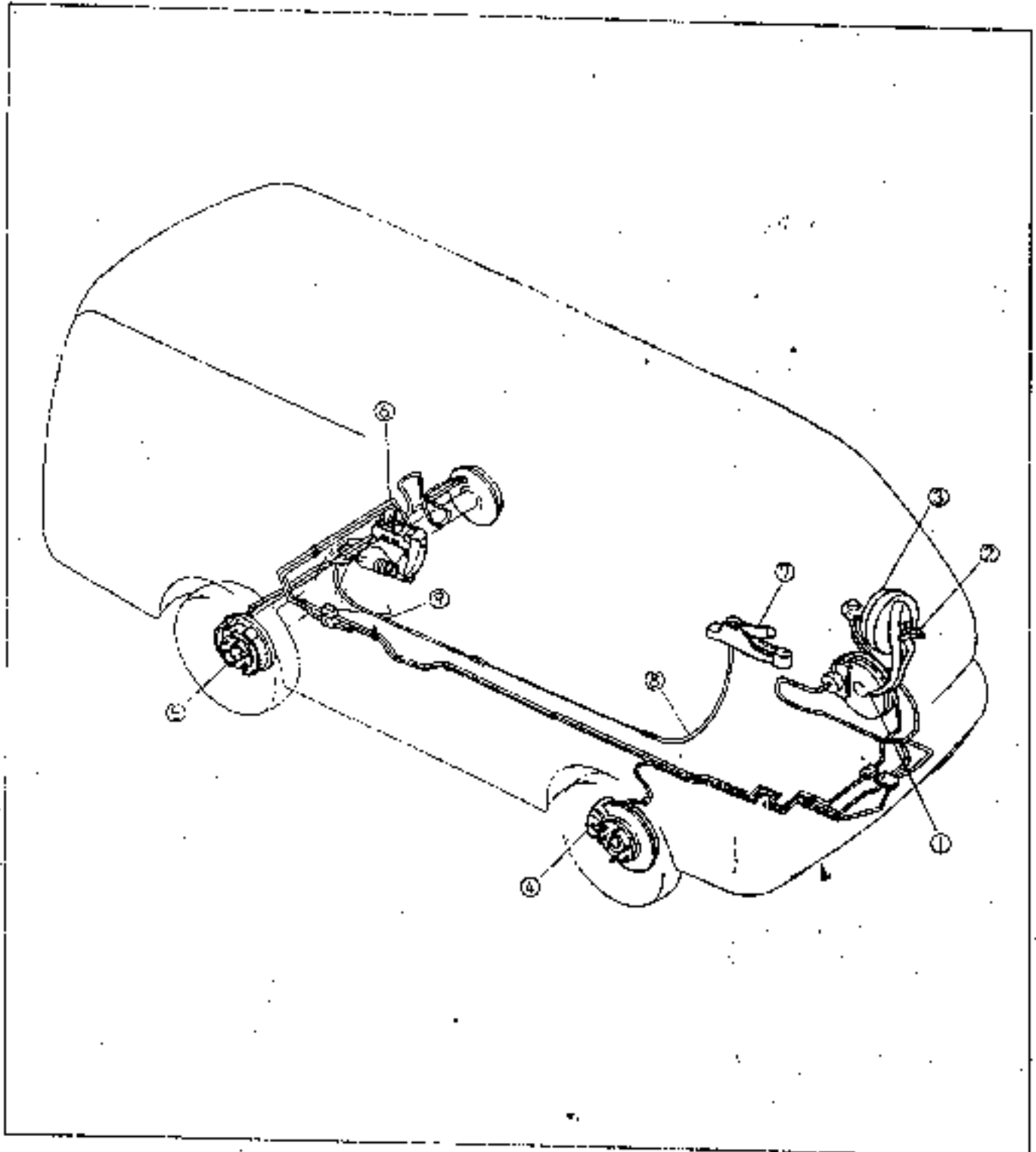

- 1 Brake pedal
- 2 Brake master cylinder
- 3 Power brake unit
- 4 Front disc plate
- 5 Rear drum brake

- 6 Load sensing proportioning valve(LSPV)
- 7 Parking brake lever
- 8 Parking brake cable(front)
- 9 Parking brake cable(rear)

7/11/052001

## TROUBLESHOOTING GUIDE

Problem	Possible cause	Action
Poor braking	<ul style="list-style-type: none"> <li>Brake fluid leak</li> <li>Air in pipe</li> <li>Worn pad and lining</li> <li>Pad or lining stained with brake fluid, grease or water</li> <li>Harden surface of pad or lining, poor contact</li> <li>Malfunction of disc brake piston</li> <li>Malfunction of master cylinder or wheel cylinder</li> <li>Malfunction of power brake unit</li> <li>Malfunction of check valve (vacuum hose)</li> <li>Damaged vacuum hose</li> <li>Aged flexible hose</li> <li>Malfunction of LSPV</li> </ul>	<ul style="list-style-type: none"> <li>Repair</li> <li>Bleed air</li> <li>Replace</li> <li>Clean or replace</li> <li>Grind or replace</li> <li>Replace</li> <li>Repair or replace</li> <li>Replace</li> <li>Replace</li> <li>Replace</li> <li>Replace</li> <li>Adjust or replace</li> </ul>
Pull to right or left	<ul style="list-style-type: none"> <li>Worn pad or lining</li> <li>Pad or lining stained with brake fluid, grease or water</li> <li>Harden surface of pad or lining, poor contact</li> <li>Abnormally worn disc or lining or twisted</li> <li>Backing plate bolts loose or deformed</li> <li>Malfunction of wheel cylinder</li> <li>Incorrect adjustment of wheel alignment</li> <li>Inconsistent tire air pressure</li> </ul>	<ul style="list-style-type: none"> <li>Replace</li> <li>Clean or replace</li> <li>Grind or replace</li> <li>Repair or replace</li> <li>Tighten or replace</li> <li>Repair or replace</li> <li>Refer to Section 54</li> <li>Refer to Section 53</li> </ul>
Brakes do not release	<ul style="list-style-type: none"> <li>No clearance of brake pedal</li> <li>Incorrect adjustment of push rod clearance</li> <li>Clogged master cylinder return port</li> <li>Poor returning of shoe</li> <li>Poor returning of wheel cylinder</li> <li>Malfunction of disc brake piston seal</li> <li>Excessively worn disc plate</li> <li>Incorrect adjustment of wheel bearing preload</li> </ul>	<ul style="list-style-type: none"> <li>Adjust</li> <li>Adjust</li> <li>Clean</li> <li>Clean or replace</li> <li>Clean or replace</li> <li>Replace</li> <li>Replace</li> <li>Refer to Section 50</li> </ul>
Excessive pedal stroke	<ul style="list-style-type: none"> <li>Incorrect adjustment of pedal play</li> <li>Worn lining</li> <li>Damaged master cylinder</li> <li>Air in pipe</li> </ul>	<ul style="list-style-type: none"> <li>Adjust</li> <li>Replace</li> <li>Replace</li> <li>Bleed air</li> </ul>
Noise or vibration during braking	<ul style="list-style-type: none"> <li>Worn pad or lining</li> <li>Damaged surface of pad or lining</li> <li>Brakes do not release</li> <li>Foreign matter on or scratched disc plate</li> <li>Loose bolts of backing plate or caliper</li> <li>Damaged surface of disc or drum</li> <li>Poor pads or lining contacts</li> <li>Lack of grease in each moving part</li> </ul>	<ul style="list-style-type: none"> <li>Replace</li> <li>Grind or replace</li> <li>Repair</li> <li>Clean</li> <li>Tighten</li> <li>Repair</li> <li>Repair or replace</li> <li>Apply grease</li> </ul>
Malfunction of parking brakes	<ul style="list-style-type: none"> <li>Excessive lever stroke</li> <li>Stuck or damaged brake cable</li> <li>Lining stained with brake fluid or oil</li> <li>Harden lining surface or poor contact</li> </ul>	<ul style="list-style-type: none"> <li>Adjust</li> <li>Repair or replace</li> <li>Clean or replace</li> <li>Grind or replace</li> </ul>

## ON-VEHICLE INSPECTION

## HEIGHT OF BRAKE PEDAL

## Inspection

Check if the distance between center of pedal face and floor mat meets the specification.

Height of pedal : 244 mm(9.6 in)

## Adjustment

1. Loosen lock nut (a), and adjust height by rotating push rod (b).
2. After adjusting, tighten lock nut (a).

## PEDAL PLAY

## Inspection

1. Depress the pedal several times to get air out of system.
2. Lightly depress the pedal by hand and check the pedal play.

Pedal play : 7~9 mm(0.28~0.35 in)

## Adjustment

1. Loosen lock nut (a), and adjust height by rotating push rod (b).
2. After adjusting the play, tighten lock nut (a).

## Note

- After adjusting pedal height and play, check if stop lamps work properly and adjust as required.

## PEDAL-TO-FLOOR CLEARANCE

## Inspection

1. Apply pedal with 588N (60kg, 132 lb) force after starting engine, and inspect if the clearance between floor and center of pedal face is as specified.

Pedal-to-floor clearance : 74 mm(2.9 in)

2. If the distance is less than the specification, check for the followings.

- (1) Air in brake system
- (2) Worn pads
- (3) Excessive clearance of shoe
- (4) Automatic adjuster malfunction

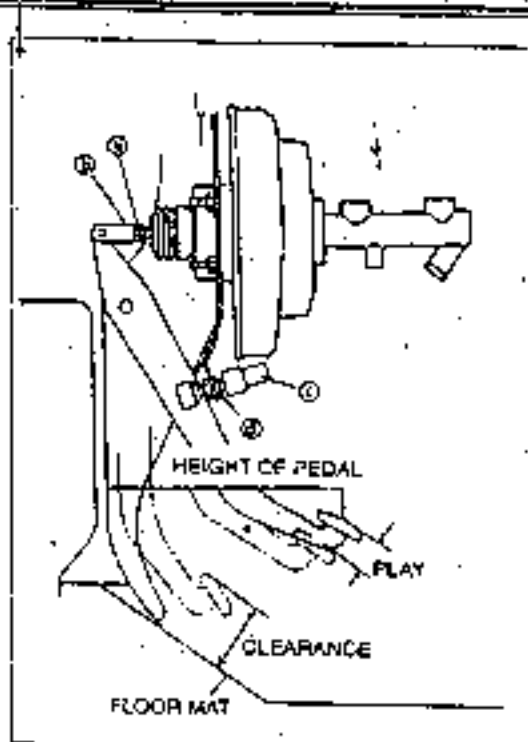

PHB052602

Disassembly part			Air bleeding location				
			Front		LSPV	Rear	
			Right	Left			Right
Master cylinder			○	○	○	○	
LSPV			—	—	○	○	
Wheel cylinder	Front	Right	○	○	—	—	
		Left	○	○	—	—	
	Rear	Right	—	—	—	○	
		Left	—	—	—	○	

## BRAKE PEDAL

## REMOVAL/INSTALLATION

1. Remove in the order as shown in the figure.
2. Inspect all parts and repair or replace as required.
3. Install in the reverse order of removal.
4. After installation, inspect and adjust pedal height and play.

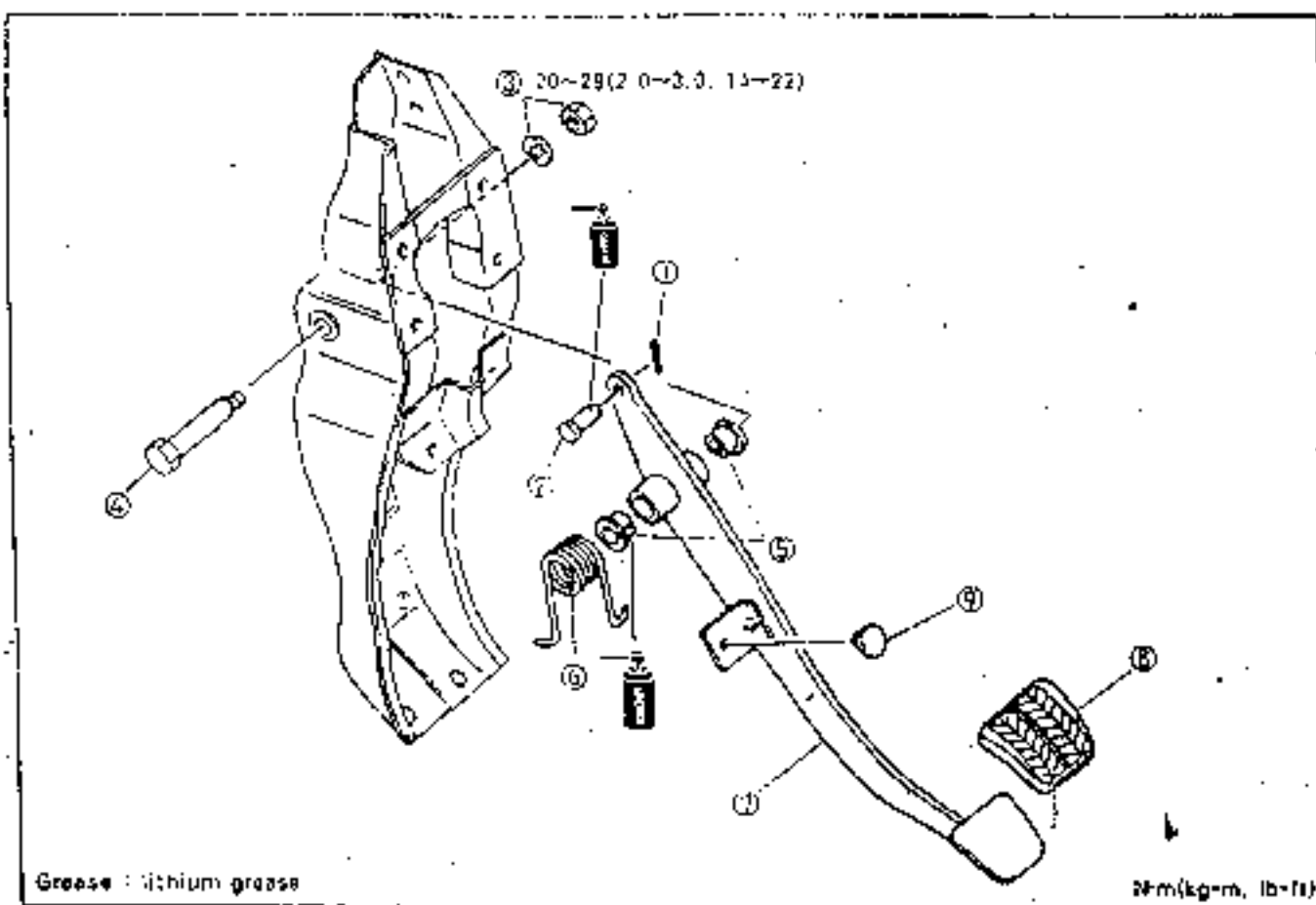

AN9052003

1. Pin joint
2. Snap pin
3. Nut/washer
4. Bolt
5. Bushing(2EA)

6. Return spring
7. Brake pedal
8. Pedal pad
9. Stop rubber

## INSPECTION

## Brake pedal

1. Inspect for worn bushing, pedal bounce, damaged return spring, and bent bolts, and replace if necessary.

## Stop lamp switch

1. Disconnect stop lamp switch connector.
2. Connect an ohmmeter and check for continuity when applying pedal.

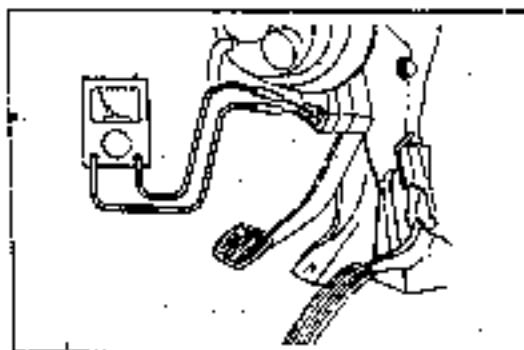

AN9052004



## MASTER CYLINDER

### REMOVAL/INSTALLATION

1. Remove in the order as shown in the figure.
2. Install in the reverse order of removal.
3. After installation, fill reservoir tank, check for fluid leakage and bleed brake system.

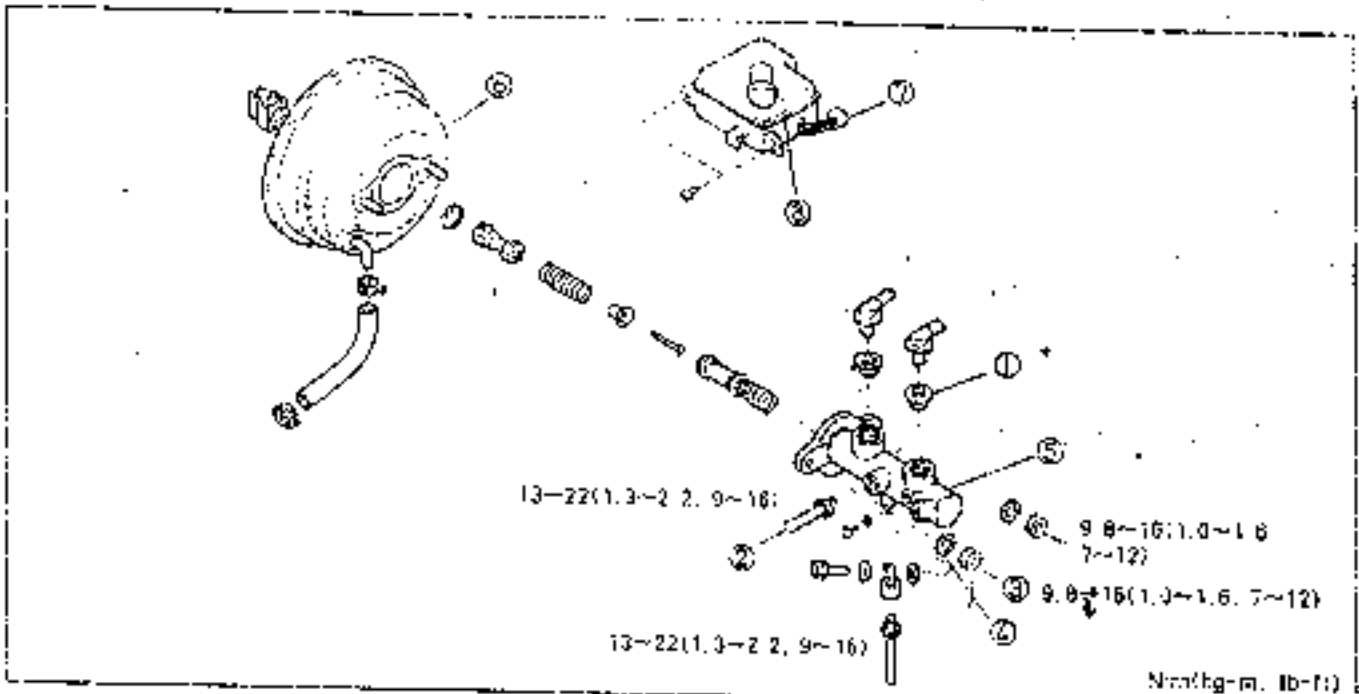

- |                   |                                       |
|-------------------|---------------------------------------|
| 1. Rubber packing | 5. Master cylinder                    |
| 2. Brake pipe     | 6. Power brake unit                   |
| 3. Nut            | 7. Brake fluid level sensor connector |
| 4. Spring washer  | 8. Reservoir tank                     |

### INSPECTION

#### Master cylinder

1. Measure clearance between power brake unit push rod and master cylinder piston using SST.
2. If the clearance is not within specification, adjust it once again by rotating push rod.

#### Note

Vacuum pressure mmHg(kPa)	Clearance between push rod and piston (mm)	mm(in)
500(66)	0.1-0.4(0.004-0.016)	

#### Brake fluid level sensor

1. Check for continuity with brake fluid level in the range of MIN+3mm(0.118 in) using an ohmmeter.

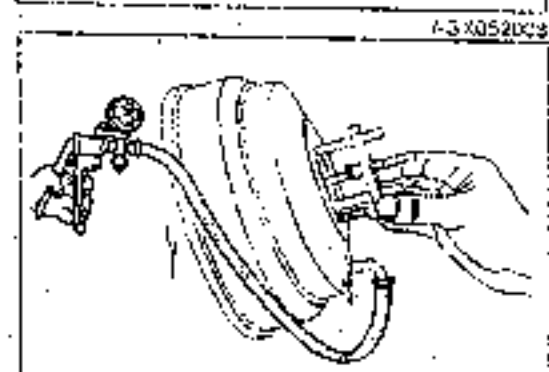
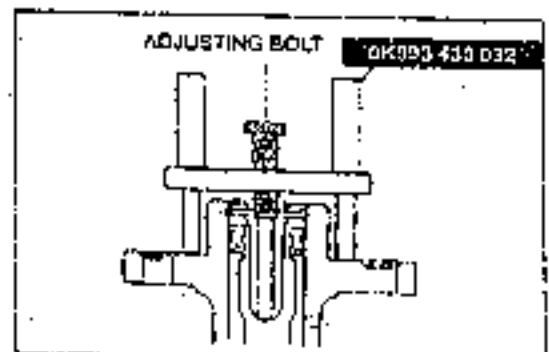

## LOAD SENSING PROPORTIONING VALVES(LSPV)

### REMOVAL/INSTALLATION

1. Remove in the order as shown in the figure.
2. Install in the reverse order of removal.
3. After installation, fill reservoir tank, check for fluid leakage and bleed brake system.

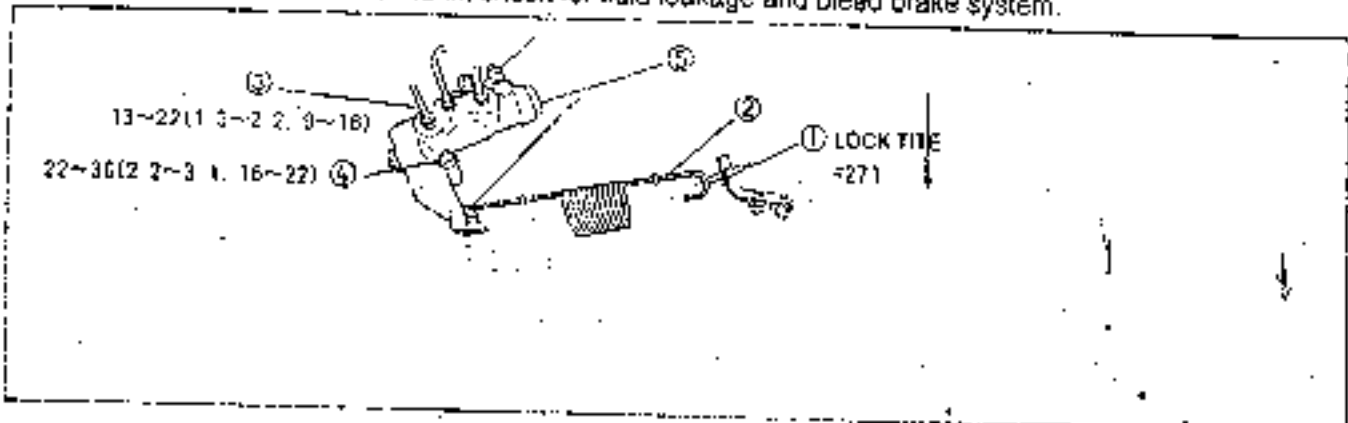

1. Adjusting nut  
2. Spring  
3. Brake pipe  
4. Bolt  
5. LSPV

AN6752007

### INSPECTION

#### Spring

1. Inspect length of spring after placing vehicle on the ground level with no occupants.

Specification : 89.5~90.5 mm(3.52~3.56 in)

2. If the length is not within the specification, adjust by rotating adjusting nut and apply lock wire. (#271)

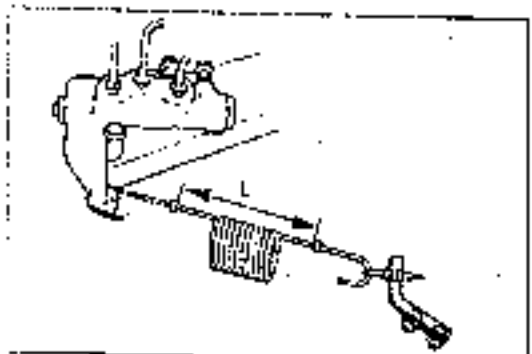

AN6752008

#### LSPV

1. Install pressure gauge in front and rear brake wheel.
2. Bleed air in brake line.
3. Apply brake pedal until fluid pressure of front wheel reaches A, B and inspect if the fluid pressure A, B of rear wheel is within specification.

Vehicle		With no occupants				Normal condition			
		A	A'	B	B'	a	a'	b	b'
12 seats	12P	16 (227)	16 (227)	26 (389)	55 (711)	55 (782)	55 (782)	69 (900)	100 (1421)
	9P	13 (185)	13 (185)	24 (341)	50 (711)	32 (455)	32 (455)	48 (654)	80 (1137)
	6 VAN	12 (171)	12 (171)	23 (327)	50 (711)	62 (881)	62 (881)	76 (1053)	110 (1553)
	3 VAN	12 (171)	12 (171)	23 (327)	50 (711)	60 (833)	60 (833)	75 (1056)	110 (1553)

kg/cm<sup>2</sup>(psi)

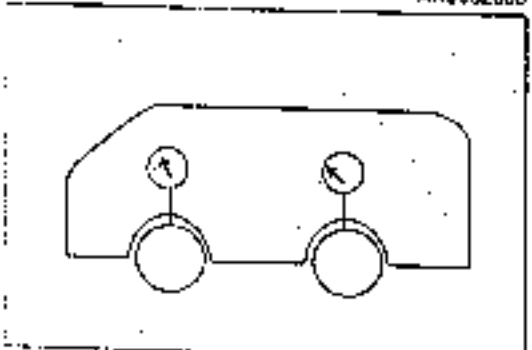

AN6752009

Vehicle		With no occupants				Normal condition			
		A	A'	B	B'	a	a'	b	b'
15 seats	15P	26 (368)	28 (393)	38 (52)	60 (860)	96 (1385)	96 (1365)	110 (1564)	143 (2033)
	3 VAN	34 (483)	34 (483)	42 (597)	62 (876)	106 (1507)	106 (1507)	120 (1708)	153 (2176)
	6 VAN	30 (427)	30 (427)	40 (559)	63 (891)	110 (1554)	110 (1554)	125 (1778)	160 (2275)

kg/cm<sup>2</sup>(psi)

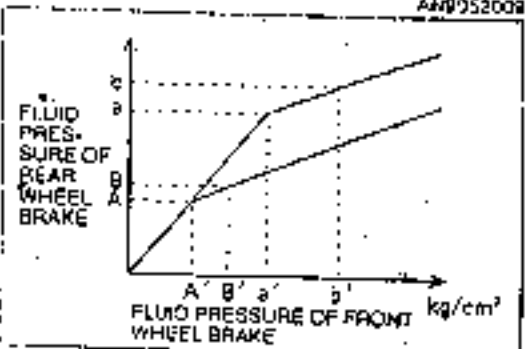

AN6752017

#### Caution

- In case of defective LSPV, replace as an assembly.

## FRONT DISC BRAKE

## REMOVAL/INSTALLATION

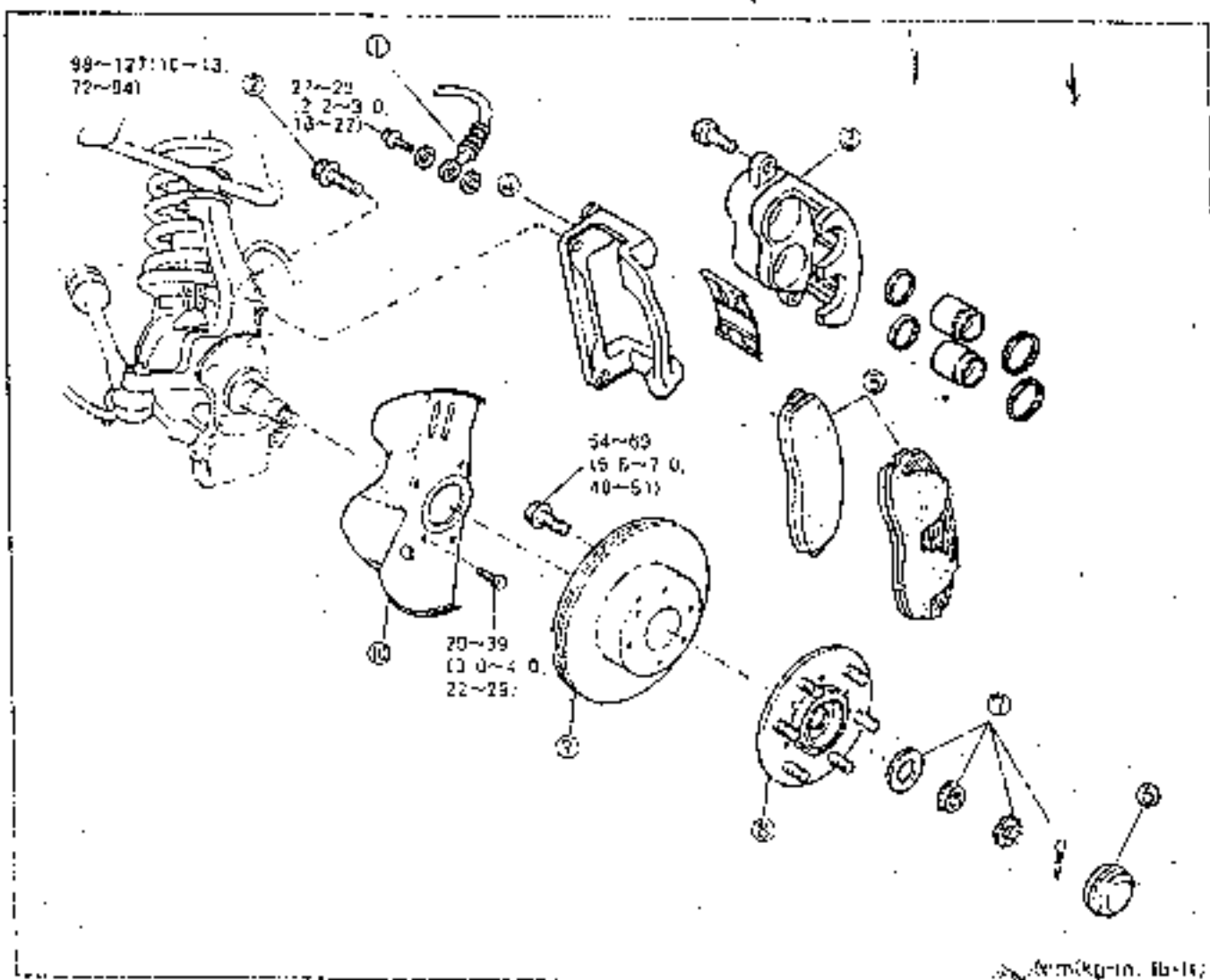

1. Flexible hose
2. Ball
3. Caliper
4. Supporting plate
5. Brake pads

6. Hub cap
7. Pin washer nut
8. Front hub
9. Disc plate
10. Dust cover

## Inspection

1. Thickness of disc pad  
Standard : 11.0-11.5 mm(0.433-0.452 in)  
Minimum: 1.5 mm(0.059 in)
2. Disc plate  
Standard : 26 mm(1.023 in)  
Minimum: 24 mm(0.944 in)
3. Runout (mm) {at 8-12 mm(0.315-0.472 in) from the outside edge of disc}  
Maximum: 0.1 mm(0.004 in)

## Caution

- Do not allow grease and oil on the brake pad surfaces.

## REAR DRUM BRAKE

## REMOVAL/INSTALLATION

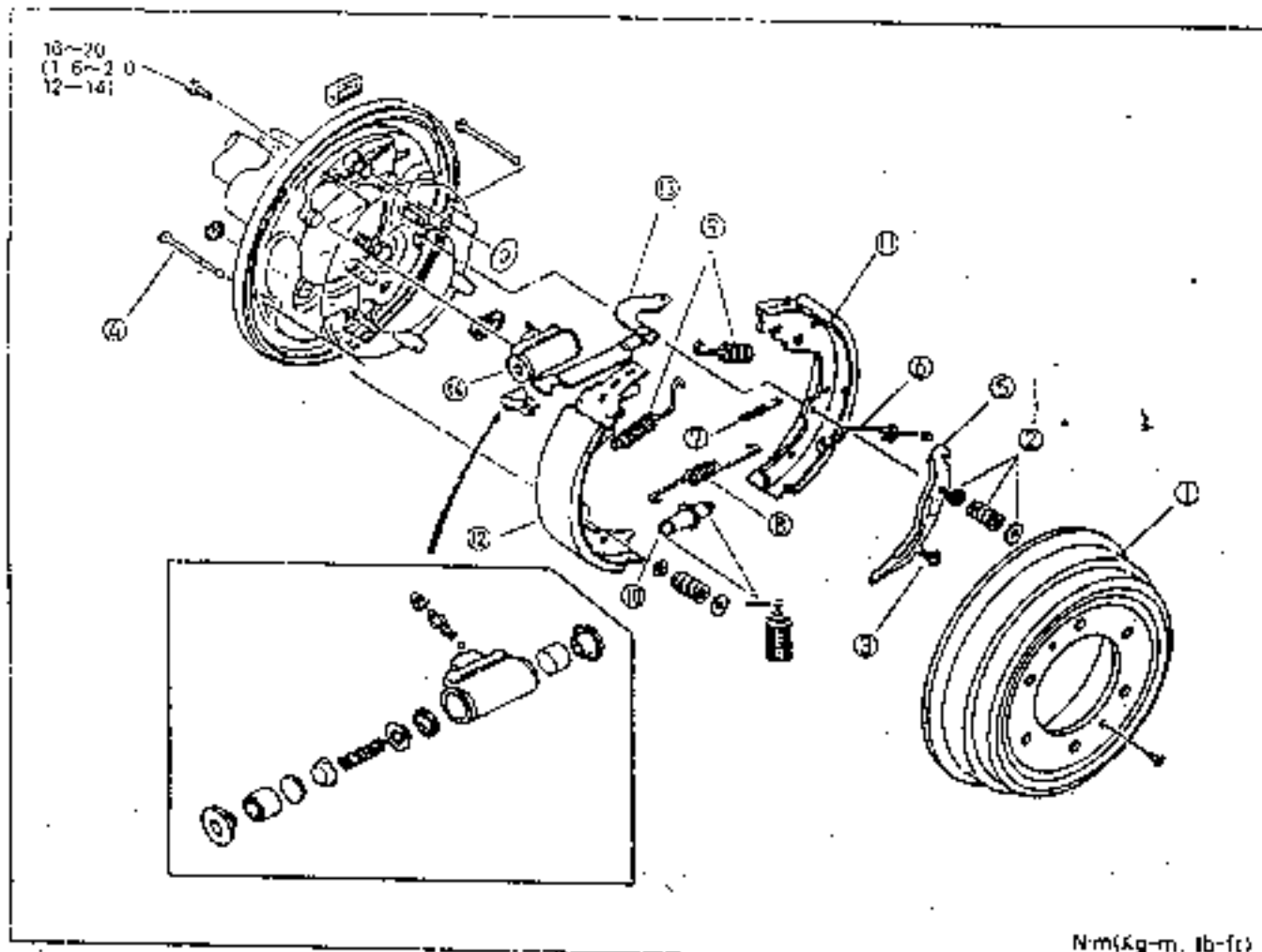

Nm(Kg-m, lb-ft)

AA005201

- |                            |                    |   |
|----------------------------|--------------------|---|
| 1. Brake drum              | 7. Pull off spring | 13. Operating lever, anti-rattle spring |
| 2. Shoe hold spring sleeve | 8. Shoe spring     | 14. Wheel cylinder                      |
| 3. Back spring             | 9. Return spring   |   |
| 4. Shoe hold pin           | 10. Adjuster       |   |
| 5. Adjusting lever         | 11. Secondary shoe |   |
| 6. Link                    | 12. Primary shoe   |   |

## INSPECTION

- Thickness of lining pads  
Specification : 5.0 mm(0.2 in)  
Minimum : 1.0 mm(0.04 in)
- Inner diameter of drum  
Specification : 260.0 mm(10.2 in)  
Limit : 261.5 mm(10.3 in)

## Caution

- At the time of assembly of shoes, do not confuse primary shoe with secondary one.
- Apply rubber grease lightly at the contact surface of shoe and back plate.
- Grease, oil or any foreign material must be kept off lining surfaces.
- After installation, adjust brakes.

## PARKING BRAKE

## REMOVAL/INSTALLATION

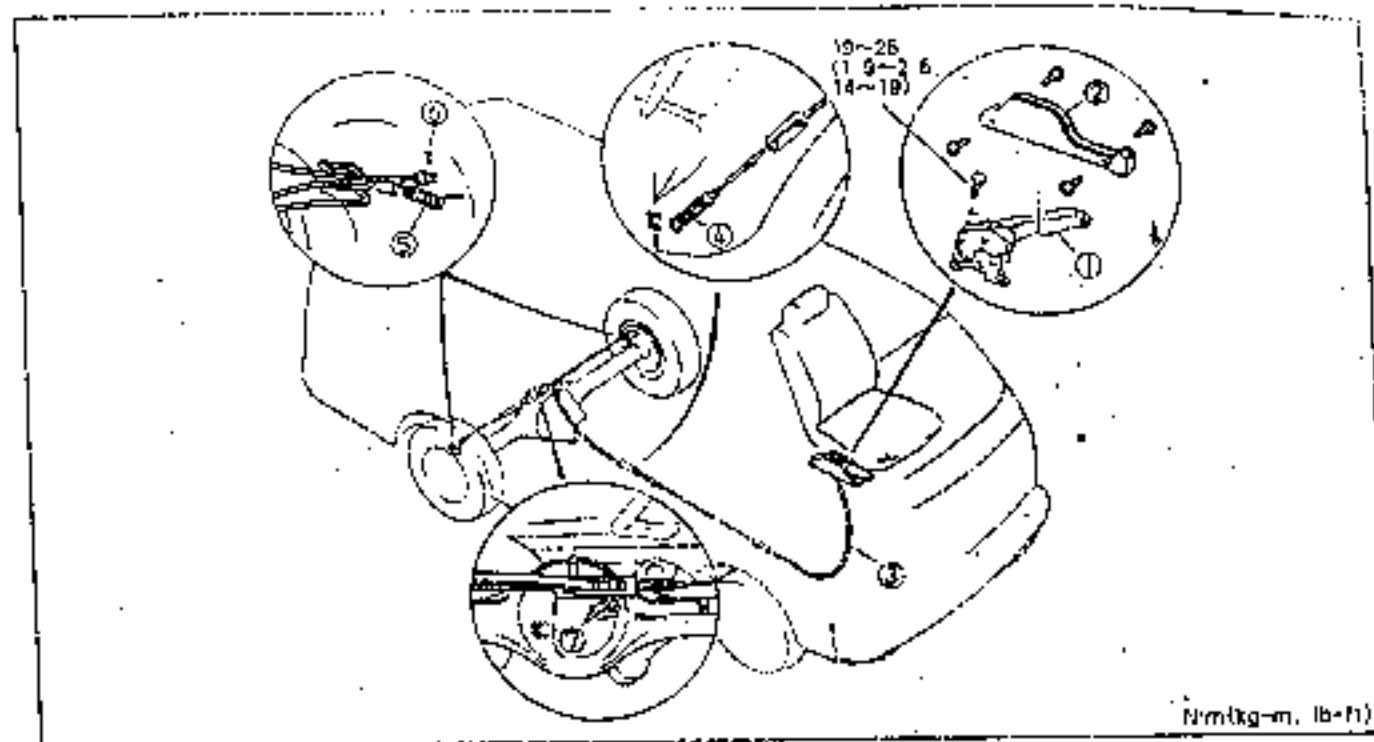

N/m(kg-m, lb-ft)

AN9052012

- |                              |                  |
|------------------------------|------------------|
| 1. Parking brake lever cover | 5. Return spring |
| 2. Parking brake lever       | 6. Pin           |
| 3. Front parking cable       | 7. Bolt          |
| 4. Rear parking cable        |                  |

## INSPECTION

1. Check parking brake lever strokes when pulled with 294N (30kg, 66 lb) of force.

Specification : 4~14 notches

2. Turn the ignition switch on and pull the parking brake one notch, and check that the parking brake warning lamp illuminates.

Parking brake one notch: Warning lamp (P) Light stay on

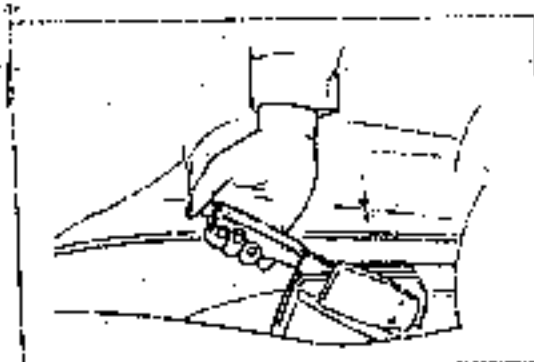

AN8052013

## ADJUSTMENT

1. Start engine before adjusting and apply brake pedal several times while moving vehicle backward.
2. Check that the rear brakes do not drag.

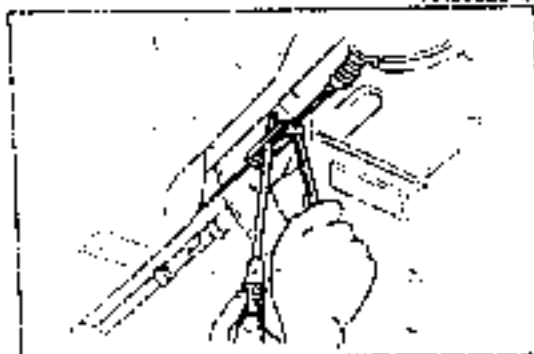





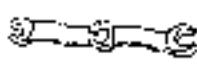

AN8052014

## SPECIFICATIONS

Items	Specifications	
Brake pedal	Type Suspension type	
	Pedal lever ratio mm(in)	4.67(0.18)
	Maximum stroke mm(in)	145(5.7)
Master cylinder	Type Tandem (Level sensor installed) - parallel type	
	Cylinder inner diameter mm(in)	ø 23.81 (For ABS ø 25.4) (0.94, 1)
Front disc brake	Type Ventilated disc	
	Cylinder bore mm(in)	ø 46 x 2(1.8 x 2)
	Pad size (area x thickness) mm <sup>2</sup> x mm(in <sup>2</sup> x in)	6080 x 10(9.4 x 0.4)
	Disc plate size (outer diameter x thickness) mm(in)	258 x 25(10.16 x 1.02)
Rear drum brake	Type Dup servo	
	Wheel cylinder inner diameter mm(in)	ø 19.05mm(0.75)
	Lining size (width x length x thickness) mm(in)	261 x 45 x 7mm(10.3 x 1.8 x 0.28)
	Drum inner diameter mm(in)	ø 260mm(10.24)
	Shoe clearance adjusting Auto adjusting	
Power brake unit	Type Hydrovac type	
	Cylinder diameter mm(in)	188 + 215(+7.4 + 8.46)
Braking control system	Type LSPV <LOAD SENSING PROPORTIONING VALVE>	
Brake fluid	FMVSS NO. 118, DOT-3	
Parking brakes	Type Mechanical rear wheel braking	
	Operation method Floor lever	

## SPECIAL TOOLS

OK130 400 019 Flare nut wrench 	For brake pipes removal/installation	OK993 130 032 Adjusting gauge 	For adjusting push rod clearance
OK130 430 017 Disc brake expand tool 	For disc pads assembly	OK201 680 001 Sensor ruler installer 	For installing sensor rotor
OK670 090 A40 Bearing installer set 	For removing sensor rotor	OK011 270 001 Bearing outer race remover 	For removing front hub bearing outer race

# WHEELS AND TIRES

53

REMOVAL/INSTALLATION .....	53- 4
SPECIFICATIONS .....	53- 5
TROUBLESHOOTING GUIDE .....	53- 3

## TROUBLESHOOTING GUIDE

Problem	Possible cause	Action
Excessive or uneven tire wear	Improper tire pressure Imbalanced wheels Imbalanced tire spinning Severe driving Improper toe-in Poor braking function	Adjust Adjust Adjust Obtain new driving habits Refer to section 54 Refer to section 62
Rapid tire wear	Excessive tire pressure High speed driving with deflated tires	Adjust Adjust
Tires squeaking noise	Improper tire pressure Aged tires	Adjust Replace
Road noise and body vibration	Deflated tires Imbalanced wheels Damaged wheels or tires Uneven tire wear	Adjust Adjust Repair or replace Replace
Steering wheel vibration	Irregular tire wear Imbalanced or damaged wheels Damaged tires Imbalanced tire pressure Loose hub nuts Imbalanced wheels	Replace Repair or replace Replace Adjust Tighten Adjust
Brakes leads to one side	Imbalanced tire pressure Defected brakes	Adjust Refer to section 52
Steering wheel not properly returning	Improper tire pressure Irregular tire wear (of right and left tires) Imbalanced tire pressure Different type of tires used Improper tightening of hub nut	Adjust Replace Adjust Replace Tighten
Unstable driving	Imbalanced tire pressure Imbalanced or damaged wheels Loose hub nuts	Adjust Repair or replace Tighten
Excessive steering wheel play	Loose hub nuts Improper adjustment of front wheel bearing preload	Tighten Refer to section 50



## REMOVAL/INSTALLATION

### CAUTIONS FOR REMOVING TIRES FROM WHEEL

1. Be careful not to damage the tire bead, the wheel rim bead or the outer edge of the wheel rim.
2. Apply soapy water to the edge of the wheel and tire bead (to make an installation easier).
3. Remove rust, dust, or mud from the edge of the wheel and tire bead with wire brush, sandpaper and cloth.
4. Use only cloth for aluminum wheels. Wire brush and sandpaper are not allowed.
5. Stones, glass, and pins should be removed from tread.
6. Properly install air valve.

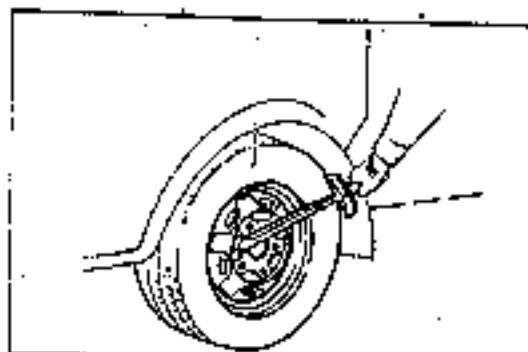

A4B053001

1. Clean contacting surface of wheels and hub.
2. Tighten hub nut to specified torque.

Tightening torque : 88~108 N.m(9~11 kg-m, 65~80 lb-ft)

#### Note

- Do not use oil for hub nuts and wheels
- Oil may cause loose hub nut and weakened tightening.

### TIRE ROTATION

Tires will be rotated at every 8,000 km driving. Rotation will increase tire life and help tires to wear evenly.

#### Caution

- Install less worn and less damaged tires to front wheel.
- After rotation, use specified tire pressure.

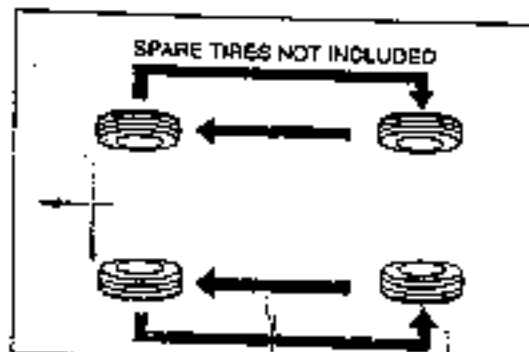

E3X059010

### WHEEL BALANCE

Standard wheel balance must be met whenever a tire is repaired or wheels are not balanced.

1. Wheel balance quantity : Less than 100g
2. Wheel balance weight : Less than 60g/use 1EA

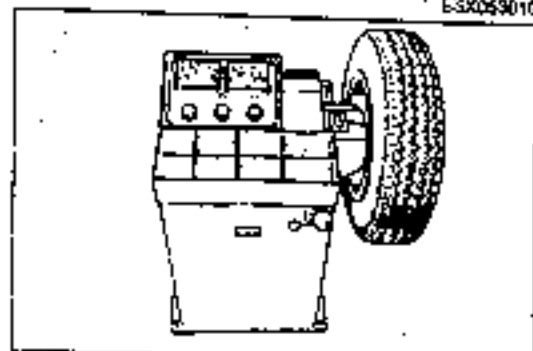

B4X053011

#### Note

- Do not use more than 2 balance weights at inner or outer wheels.
- Balance once again by installing wheel tire if total weight exceeds 100g.
- When installed balance weight, it must not come out more than 1mm from the surface of wheel. Balance weight
- Use specifications of aluminum wheel balance weight for aluminum wheels.

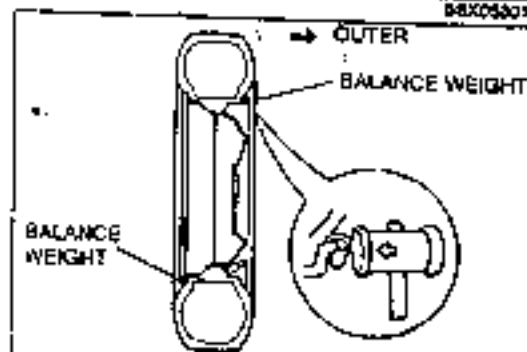

B6X063012

INSPECTION AND ADJUSTMENT

AIR PRESSURE

Inspect pressure of all tires including spare ones, using air pressure gauge.

Vehicle	Tire type	Air pressure kgf/cm <sup>2</sup> (psi)	
		Front wheel	Rear wheel
12 seats van	195R14-8PR	3.0(43)	4.0(57)
15 seats coach	205/75R14-8PR	3.5(50)	4.5(65)
12 seats coach	P215/75R14-8PR	3.5(50)	3.5(50)
15 seats van	P215/70R14	2.4(34)	2.4(34)

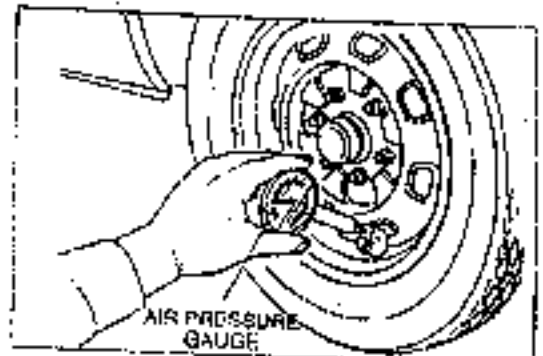

NA9053002

SPECIFICATIONS

Items		Specifications				
Wheels	Size	6-JJ x 14WDC				
	Offset	mm(in)	50 ± 1.0(2 ± 0.04)			
	Pitch circle diameter	mm(in)	ø 139.7(5.5)			
	Material	Steel(aluminum)				
Tires	Size	195R14-8PR	205/75R14-8PR	P205/75R14-8PR	P215/70R14	
	Air pressure kgf/cm <sup>2</sup> (psi)	Front wheel	3.0(43)	3.5(50)	3.5(50)	2.4(34)
		Rear wheel	4.0(57)	4.5(65)	3.5(50)	

SIZE OF WHEELS AND TIRES

Item	Torque N·m (kg·m, lb·ft)
Hub nuts	85~108(9~11, 65~80)

# SUSPENSION

54

CAMBER AND CASTER .....	54- 8
FRONT SHOCK ABSORBER AND SPRING .....	54-11
FRONT SUSPENSION .....	54- 9
LOWER ARM .....	54-13
OUTLINE .....	54- 3
REAR SUSPENSION(5 LINK TYPE) .....	54-14
REAR SUSPENSION(LEAF SPRING TYPE) .....	54-15
SPECIAL TOOLS .....	54-16
SPECIFICATIONS .....	54-16
STABILIZER .....	54-10
TROUBLESHOOTING GUIDE .....	54- 8
UPPER ARM .....	54-12
WHEEL ALIGNMENT .....	54- 7

## OUTLINE

## FRONT SUSPENSION

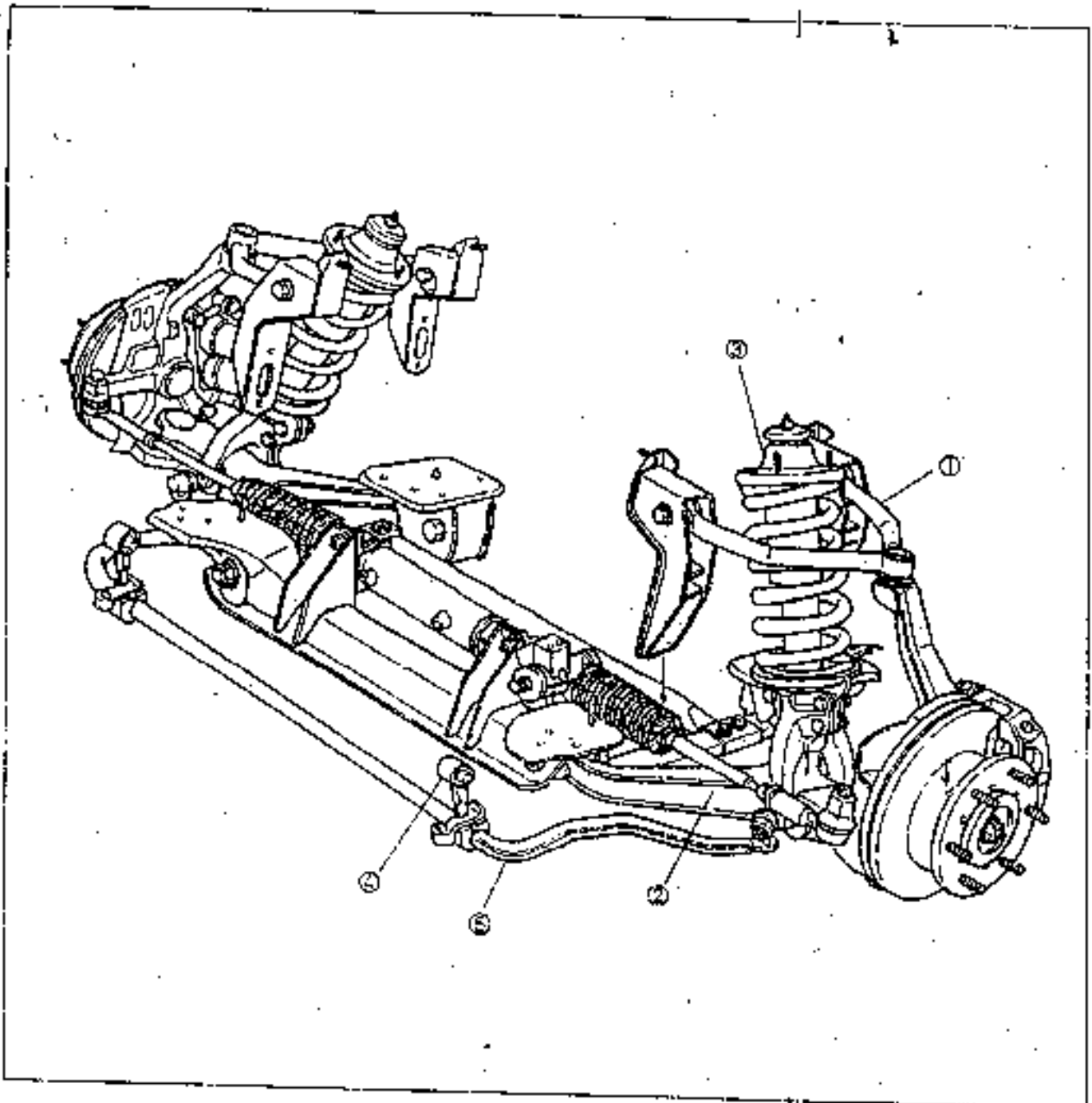

1. Upper arm
2. Lower arm
3. Front shock absorber and spring

4. Pivot link
5. Stabilizer

AN9054001

**Caution**

- Tightening front suspension nuts and links to specifications should be performed with vehicle grounded.

REAR SUSPENSION(5 LINK TYPE) : 12 seats coach

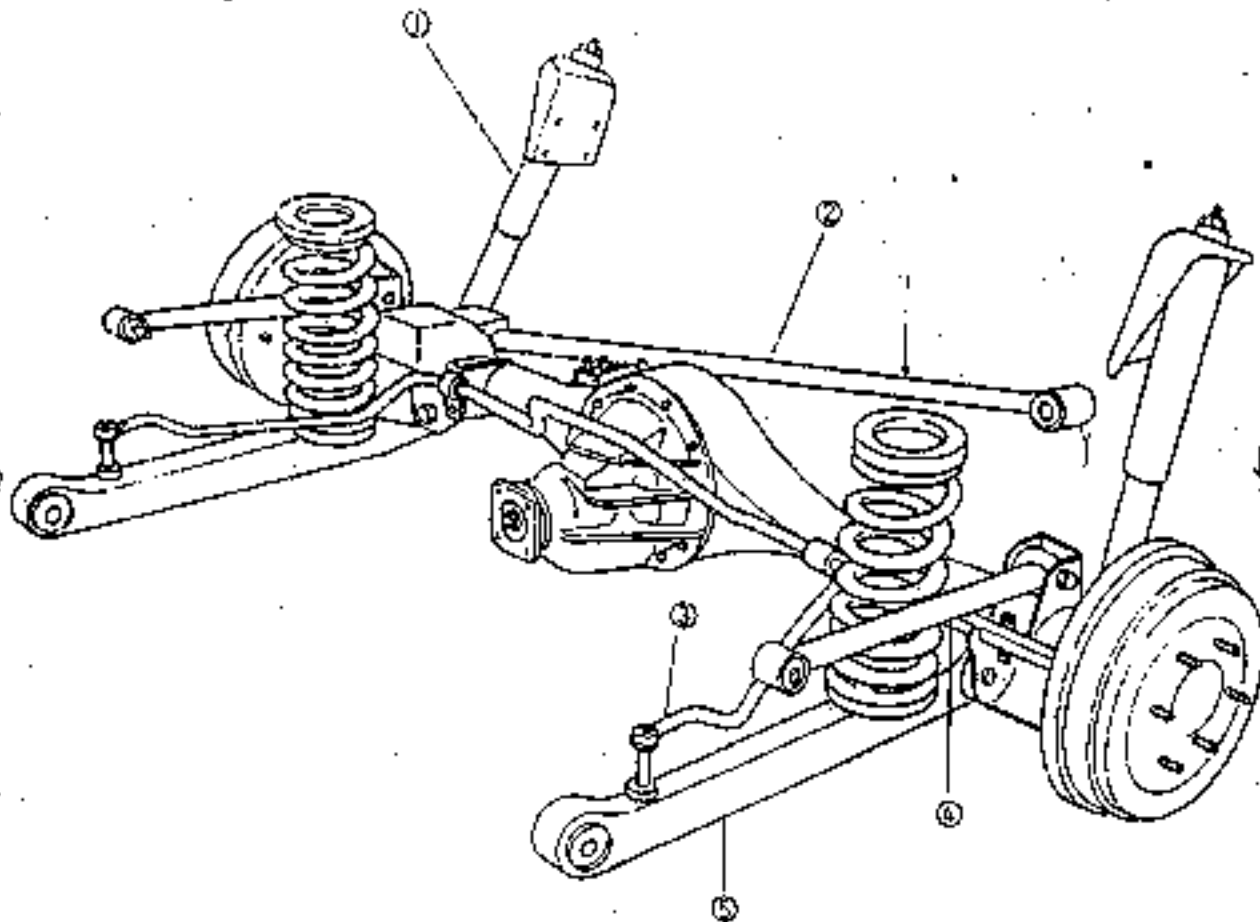

1. Rear shock absorber
2. Penhard rod
3. Stabilizer

4. Upper arm assembly
5. Lower arm assembly

AN9064002

REAR SUSPENSION(LEAF SPRING TYPE) : Van, 15 seats

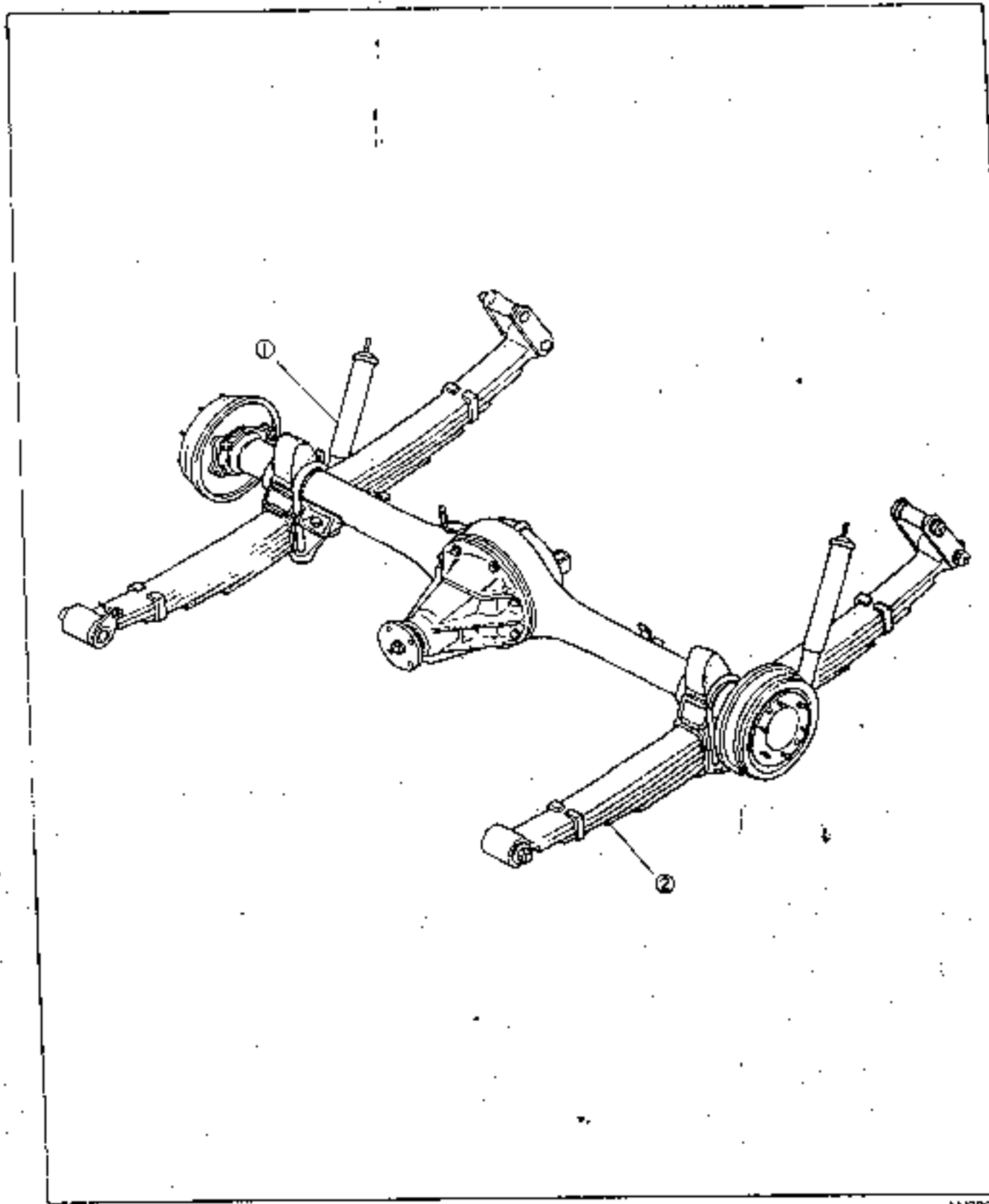

1. Rear shock absorber

2. Leaf spring assembly

AN8054003

## TROUBLESHOOTING GUIDE

Problem	Possible cause	Action
Body rolls	Damaged stabilizer Worn and damaged stabilizer bushings Worn and damaged lower arm bushings Malfunctioning shock absorber	Replace Replace Replace Replace
Poor riding	Damaged coil spring and leaf springs broken Malfunctioning shock absorber	Replace Replace
Noise from suspension	Inadequate lubrication or wear of lower arm ball joints Loose bolts and nuts Malfunctioning shock absorber Worn and damaged stabilizer bushings Worn and damaged lower arm bushings	Replace, Lubricate Tighten Replace Replace Replace
Unstable ride	Improper tire pressure Damaged coil springs Poor shock absorber Worn and damaged upper arm and lower arm bushings Worn and damaged stabilizer bushings Improper wheel alignment Damaged ball joints of upper arm and lower arm Failure of steering system Deformed wheel and unbalanced wheel Loose bolts and nuts	Adjust Replace Replace Replace Replace Adjust Replace Refer to section 51 Refer to section 53 Tighten
Heavy steering wheel	Inadequate lubrication or wear of lower arm ball joints Improper wheel alignment Failure of steering system Deformed wheel and unbalanced wheel	Lubricate, Replace Adjust Refer to section 51 Refer to section 53
Steering pulls to one side	Rusted coil spring and leaf spring broken Worn and damaged stabilizer bushings Worn and damaged lower arm bushings Damaged lower arm ball joints Improper wheel alignment Failure of steering system Failure of brake system Distorted wheel and imbalanced wheel Improper tire pressure	Replace Replace Replace Replace Adjust Refer to section 51 Refer to section 52 Refer to section 53 Adjust
Steering wheel vibrates	Damaged lower arm ball joints Poor shock absorber Loose shock absorber bolts and nuts Worn and damaged lower arm bushings Worn and damaged stabilizer bushings Improper wheel alignment Worn and damaged wheel bearing Failure of steering system Deformed wheel and unbalanced wheel	Replace Replace Tighten Replace Replace Adjust Replace Refer to section 51 Refer to section 53
Steering wheel does not return to center position	Stuck and damaged lower arm ball joints Improper wheel alignment Failure of steering system Deformed wheel and unbalanced wheel	Replace Adjust Refer to section 51 Refer to section 53

**MAXIMUM STEERING ANGLE****Inspection**

1. Position the front wheel on turning radius gauge and measure steering angle.

Specification : Inner : 39.12°  
Outer : 33.80°

**Adjustment**

1. Loosen the left and right tie-rod lock nuts and turn the tie-rod evenly.
2. After adjusting steering angle, adjust toe-in and then tighten lock nuts.

Torque : 69~78 N·m(7.0~ 8.0 kg·m, 51~58 lb·ft)

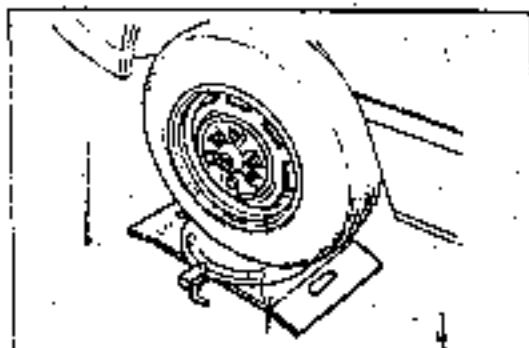

AN9054008

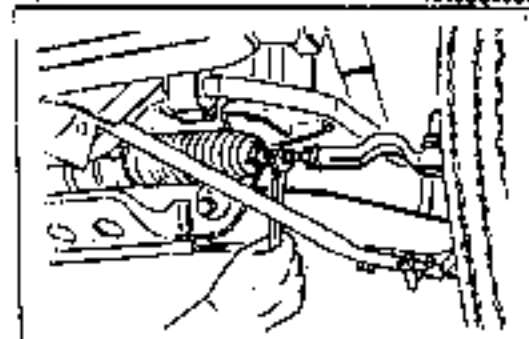

AN9054009

**CAMBER AND CASTER****INSPECTION**

1. Place the front wheel on turning radius gauge.
2. Remove the front wheel hub.
3. Attach a caster/camber gauge.
4. Measure the caster and camber.

Camber : +0.2 ± 0.5 (No Passenger Load)  
          -0.25 ± 0.5 (6 Passenger Load)  
Caster : 2.8 ± 0.5 (No Passenger Load)  
          3.4 ± 0.5 (6 Passenger Load)

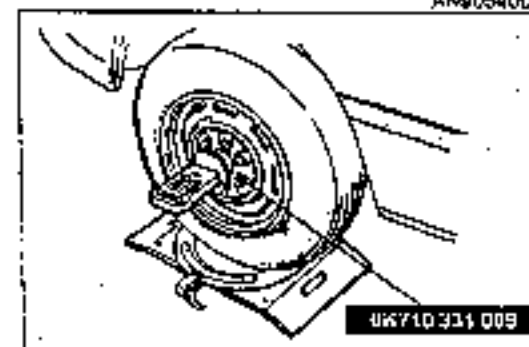

UK710331009

AN9054010

**CAMBER ADJUSTMENT(RIGHT ONE)**

1. Turn the front spindle clockwise until the number "2" mark is aligned with the vertical line on the spindle bracket.
2. Turn the rear spindle counterclockwise until the number "2" mark is aligned with the vertical line on the spindle bracket.

**Note**

- Each numerical point indicated on the spindle increases the camber by 0.4 degrees when turned to the vertical line.

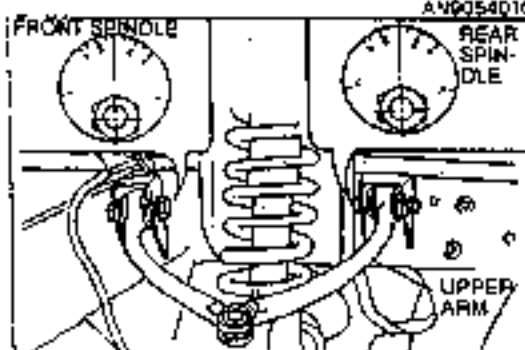

AN8054011

**CASTER ADJUSTMENT(RIGHT ONE)**

1. Turn the front spindle clockwise until the number "2" mark is aligned with the vertical line on the spindle bracket.
2. Turn the rear spindle clockwise until the number "2" mark is aligned with the vertical line on the spindle bracket.

**Note**

- Each numerical point indicated on the spindle increases the caster by 0.55 degrees when turned to the vertical line.



## FRONT SUSPENSION

## Note

- Be sure to ground vehicle when torquing nuts of arms and links to specifications.

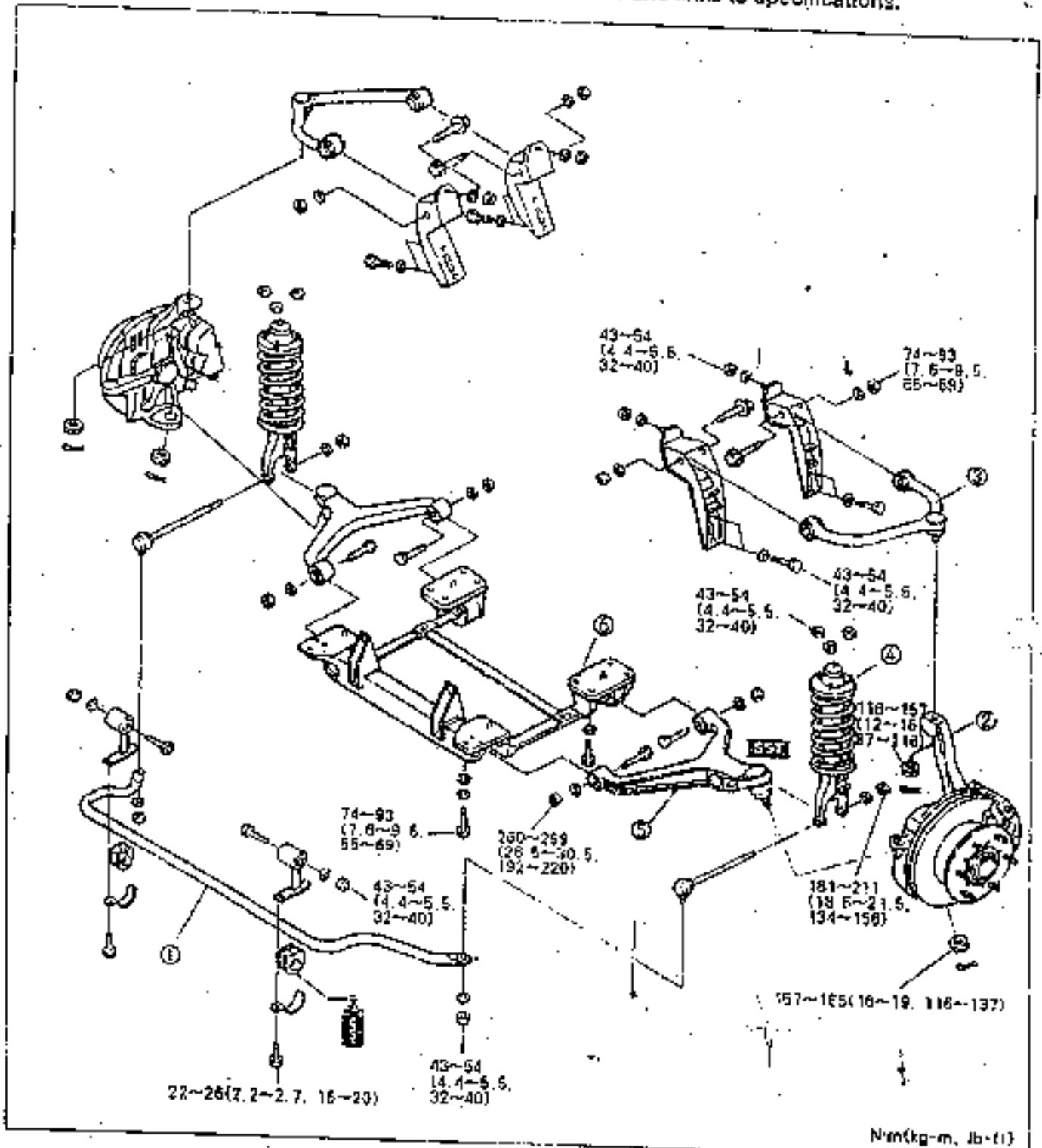

1. Stabilizer bar
2. Knuckle steering
3. Upper arm assembly

4. Front shock absorber assembly
5. Lower arm assembly
6. Cross member assembly

AS905-4012

## STABILIZER

### REMOVAL/INSPECTION/INSTALLATION

1. Raise the front part of the vehicle on jack stands.
2. Remove in the order as shown in the figure.
3. Inspect all parts and repair or replace if necessary.
4. Install in the reverse order of removal. Refer to the notes for installation when installing.

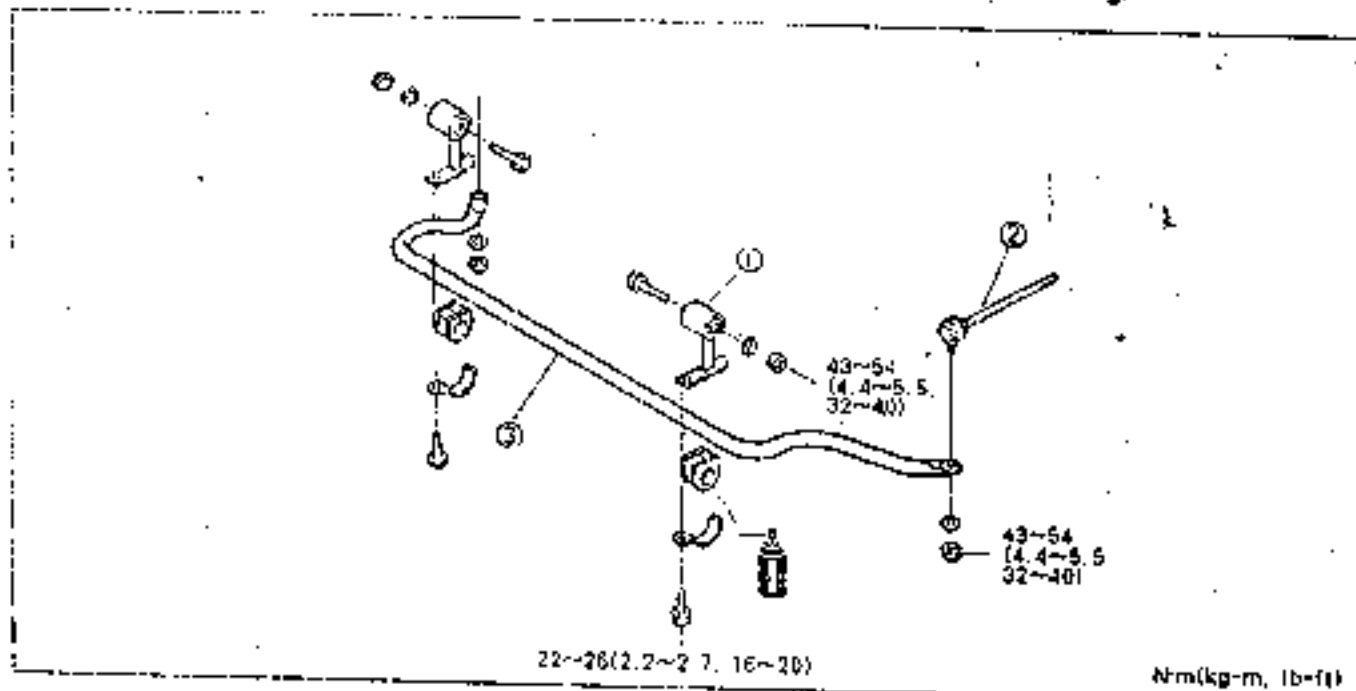

1. Pivot link
2. Drop link

3. Stabilizer

AN9054013

### Installation note

1. Apply rubber grease to inside of stabilizer bushings.
2. Align bush to the marks on the stabilizer.

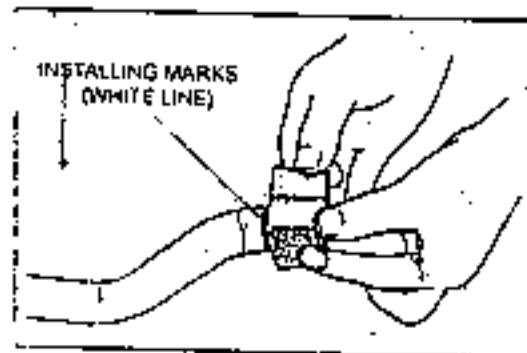

AN9054028

### Caution

- Be sure not to change assembly direction of pivot link
- Tighten bolts and nuts to specifications.

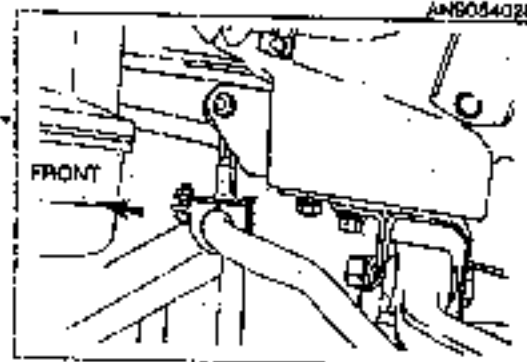

AN9054014

# FRONT SHOCK ABSORBER AND SPRING

## REMOVAL/INSTALLATION

1. Raise the front part of the vehicle on jack stands.
2. Remove wheels.
3. Remove in the order as shown in the figure.
4. Inspect all parts and repair or replace if necessary.
5. Install in the reverse order of installation.

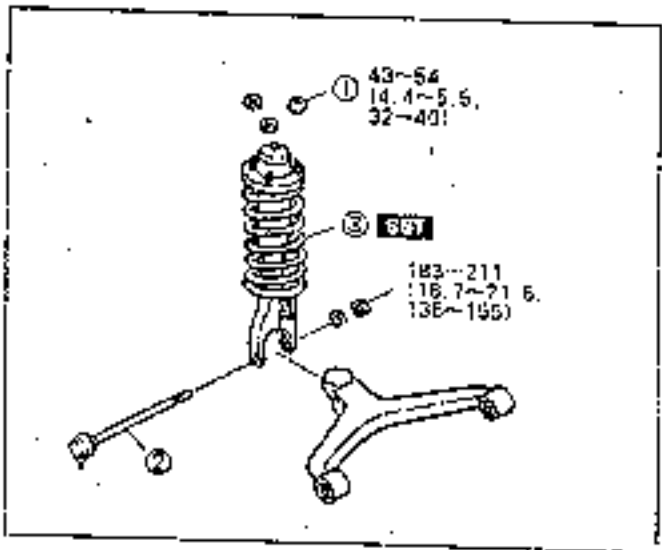

AN9054015

1. Nut
2. Drop link
3. Shock absorber and spring

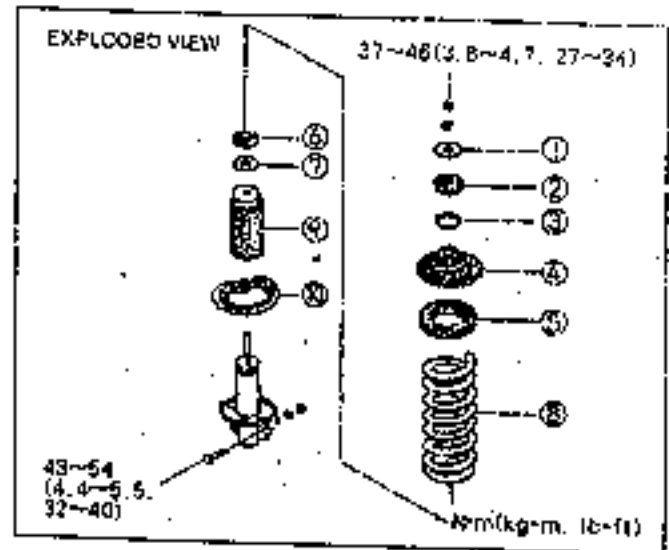

AN9064029

- |                      |                              |
|----------------------|------------------------------|
| 1. Upper retainer    | 6. Lower insulator           |
| 2. Upper insulator   | 7. Lower retainer            |
| 3. Centering washer  | 8. Coil spring               |
| 4. Mountain block    | 9. Dust boot and jounce stop |
| 5. Upper spring seat | 10. Lower spring seat        |

1. Attach shock absorber to vise.

### Caution

- Install protecting panel to vise.

2. Press coil spring using SST.
3. Set the end of the coil spring to the lower spring seat and install coil spring.
4. Tighten the piston rod nuts to specifications.

Tightening torque : 37-46 N·m(3.8-4.7 kg-m, 28-34 lb-ft)

5. Measure the projected thread of piston rod end. (12 seats)

Specification : 8.8 ± 0.5 mm(0.35 ± 0.02 in)

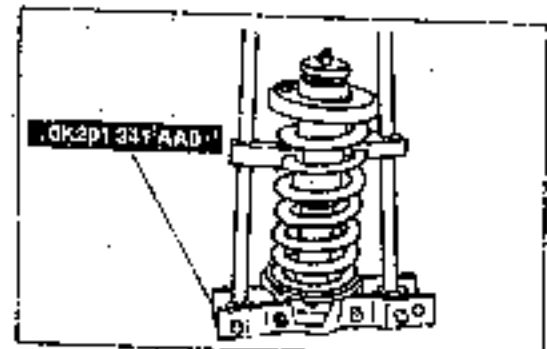

AN9054030

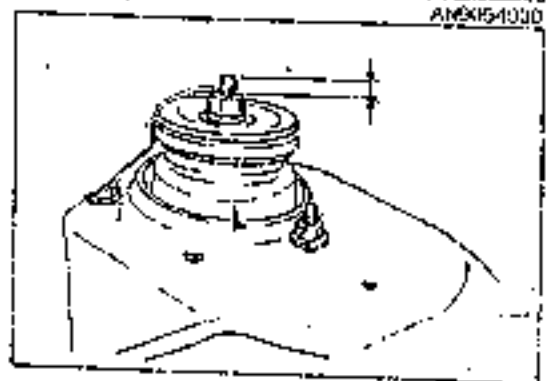

AN9064010

## UPPER ARM

## REMOVAL/INSPECTION/INSTALLATION

1. Raise the front part of the vehicle on jack stands.
2. Remove wheels.
3. Remove in the order as shown in the figure.
4. Inspect all parts and repair or replace if necessary.
5. Install in the reverse order of removal.

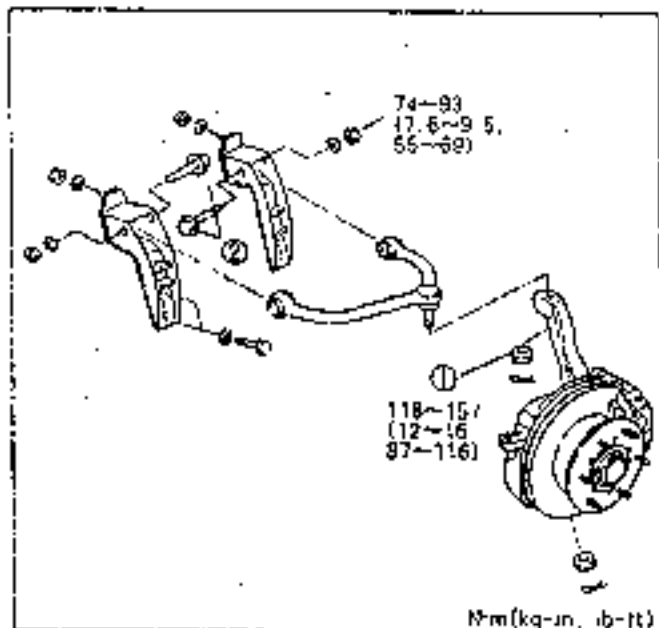

AN9054017

1. Nut
2. Front/rear spindle

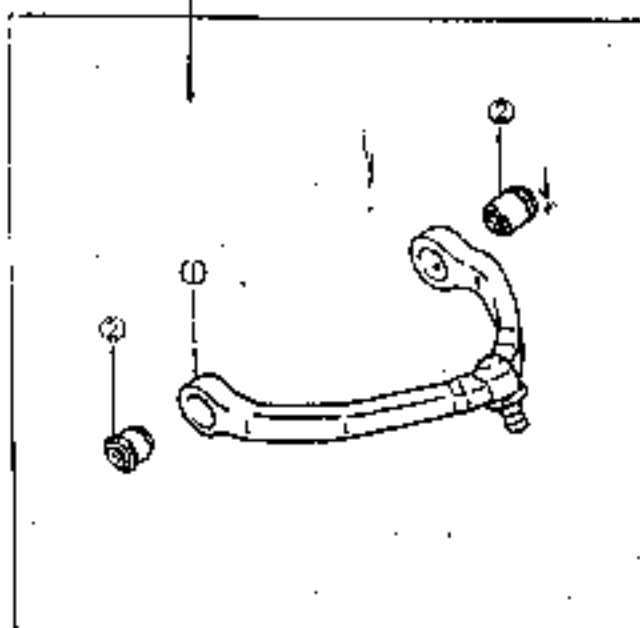

AN9054018

1. Upper arm
2. Bushing

## Removal note

1. Before loosening upper spindle nuts, mark bracket and spindle for installation.

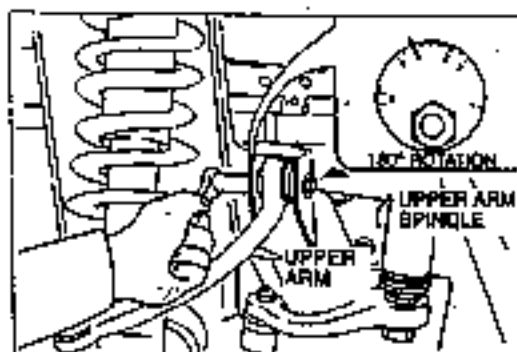

AN9054032

2. Replace upper arm bushing using SST.

## Caution

- Use soapy water when replacing with new bushing.
- Replace dust boot only when failure is detected.
- When reinstalling upper arm, adjust camber and caster.

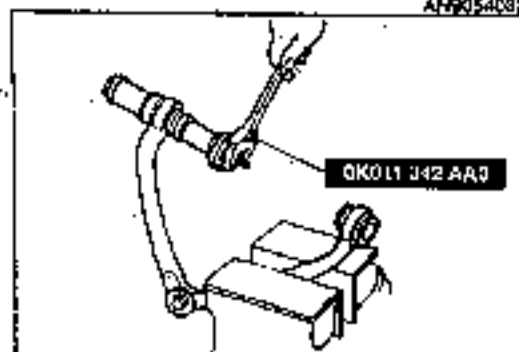

AN9043031

## LOWER ARM

## REMOVAL/INSPECTION/INSTALLATION

1. Raise the front part of the vehicle on jack stands.
2. Remove wheels.
3. Remove in the order as shown in the figure.
4. Inspect all parts and repair or replace if necessary.
5. Install in the reverse order of removal.

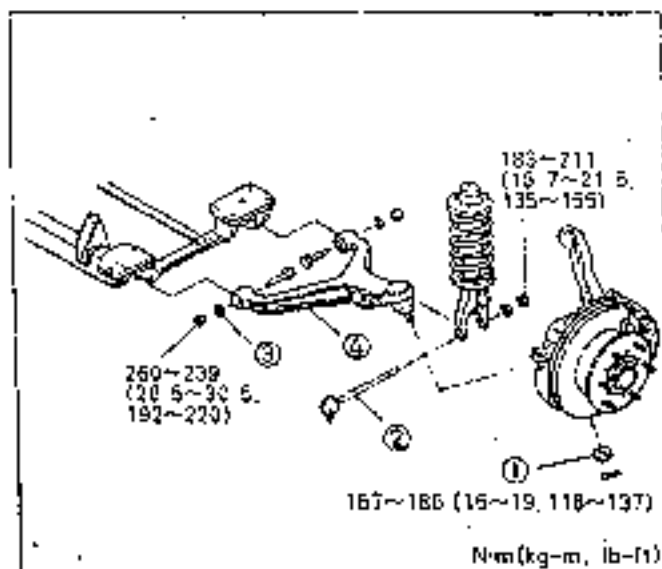

AN9054020

1. Nut(knuckle)
2. Drop link
3. Nut(lower arm)
4. Lower arm

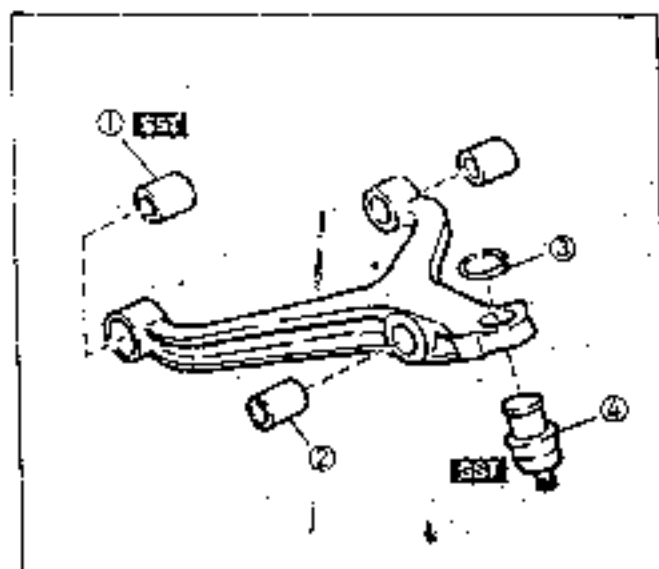

AN9054021

1. Bushing
2. Bushing
3. Snap ring
4. Ball joint

## Removal note

1. Replace lower arm bushing after installing SST to lower arm.

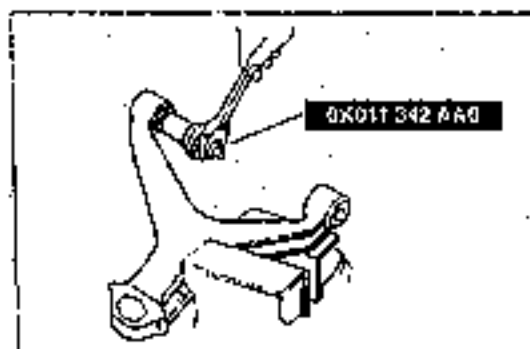

AN9054022

2. Remove knuckle after installing SST.

## Caution

- Apply soapy water when replacing with new bushing.
- When reinstalling lower arm, adjust wheel alignment if necessary.

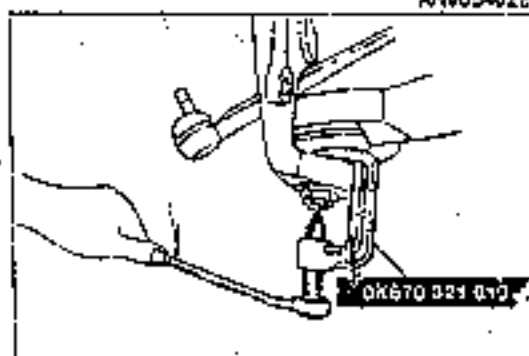

AN9054023

## REAR SUSPENSION(5 LINK TYPE) : 12 seats coach

## REMOVAL/INSPECTION/INSTALLATION

1. Remove in the order as shown in the figure and install in the reverse order of removal.
2. Inspect all parts and replace if necessary.

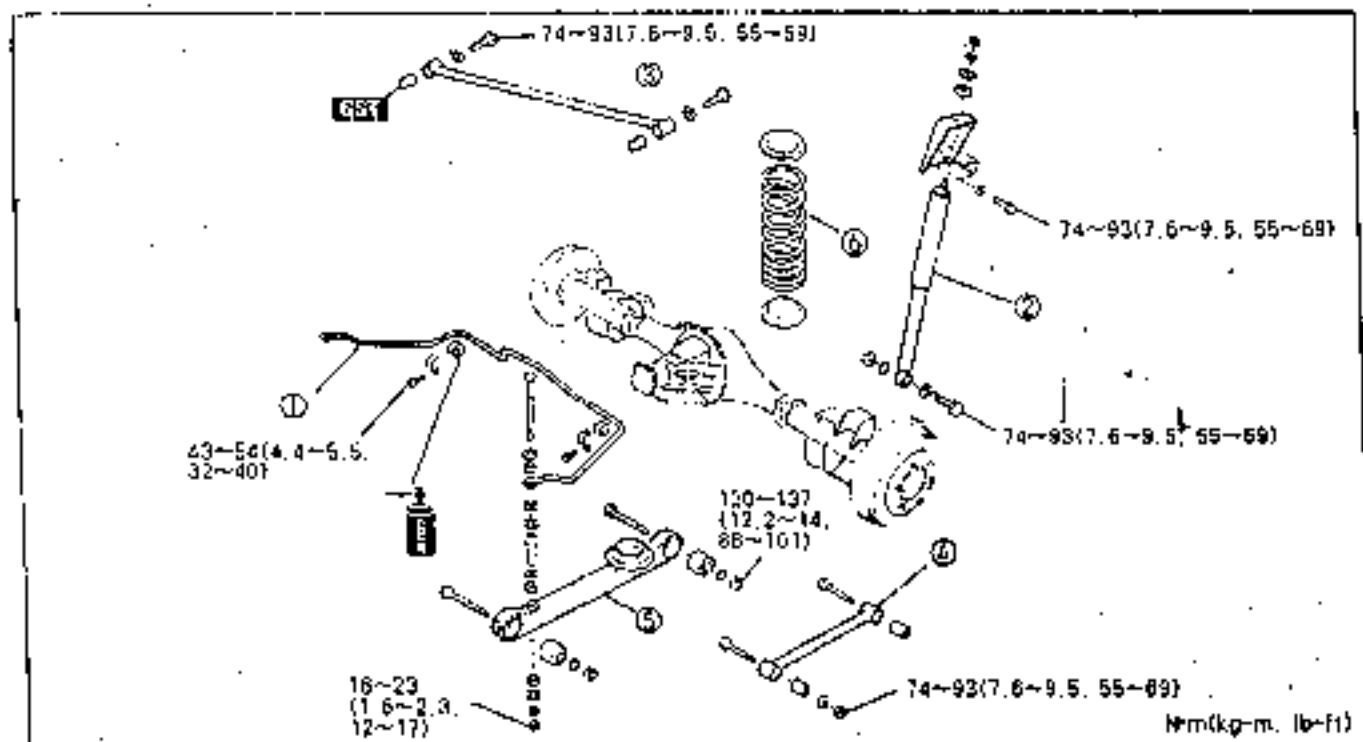

AN9054023

- |                   |                       |
|-------------------|-----------------------|
| 1. Stabilizer bar | 4. Upper arm assembly |
| 2. Shock absorber | 5. Lower arm assembly |
| 3. Panhard rod    | 6. Spring             |

## Inspection

1. Tighten the stabilizer nuts so that the specified length of the thread is exposed.

Specification : 21-25 mm(0.83-0.98 in)

2. Tighten the shock absorber nuts until the specified length of the thread is exposed.

Specification : 10.5-11.5 mm(0.41-0.45 in)

## Caution

- Tighten bolts and nuts lightly, and after lowering the vehicle(no passenger load condition) tighten it to the specified torque.
- Do not remove rear jounce stop unless damage is detected.

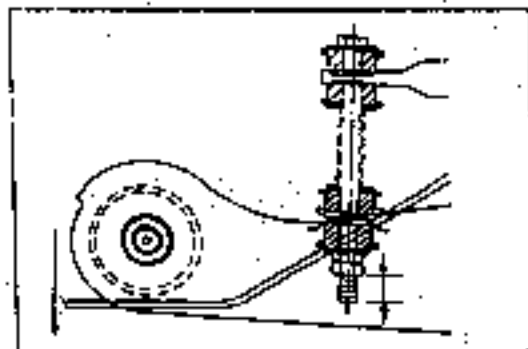

AN9054024

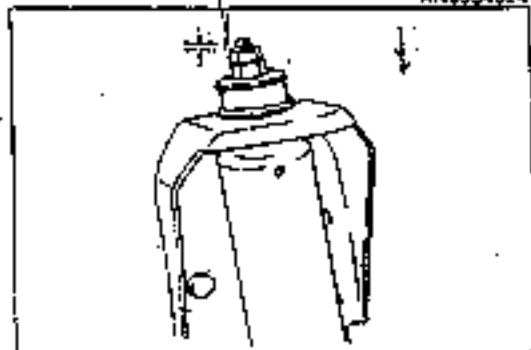

AN9054025

REAR SUSPENSION(LEAF SPRING TYPE) : Van, 15 seats

REMOVAL/INSPECTION/INSTALLATION

1. Raise the rear part of the vehicle and support it with safety stands.
2. Remove in the order as shown in the figure and install in the reverse order of removal.
3. Inspect all parts and replace if necessary.

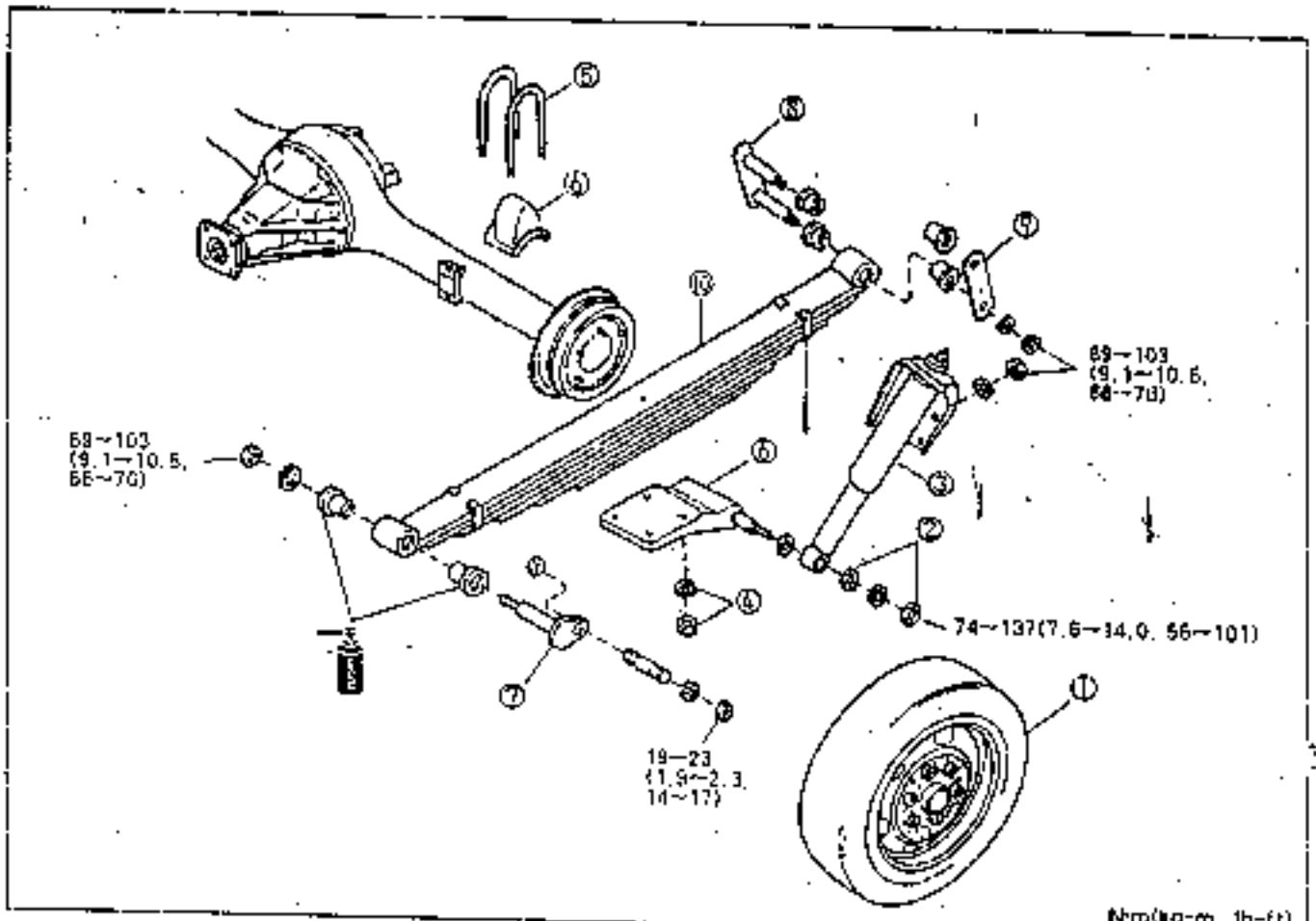

Nm(kg-m, lb-ft)

AH0051028

- |                                      |                          |
|--------------------------------------|--------------------------|
| 1. Wheel and tire                    | 7. Spring pin            |
| 2. Nut, washer, retainer and bushing | 8. Shackle pin           |
| 3. Shock absorber                    | 9. Shackle plate         |
| 4. Nut and washer                    | 10. Leaf spring assembly |
| 5. U ball and set plate              |                          |
| 6. Stopper rubber and spring clamp   |                          |

Caution

- Tighten bolts and nuts lightly, and after lowering the vehicle(no passenger load condition) tighten it to specified torque.
- Fit leaf spring dowel into axle casing hole.
- Tighten the shock absorber nuts until the specified length of the thread is exposed.

Specification : 10.5-11.5 mm(0.41-0.045 in)

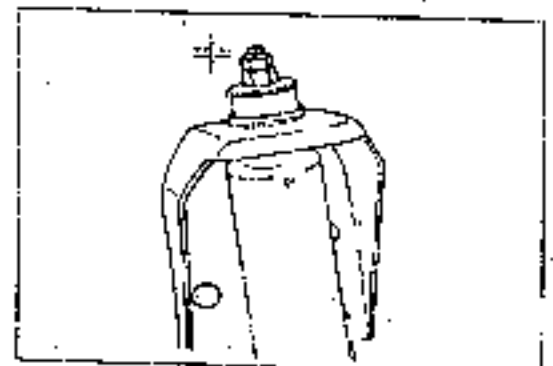







AH0054025

## SPECIFICATIONS

Items			Specifications	
Front	Suspension type		Double wishbone type coil spring	
	Wheel alignment	Toe-in	No passenger load	$+2.5 \pm 2.5$
			5 passenger load	$+2.5 \pm 2.5$
		Camber	No passenger load	$+0.2 \pm 0.5$
			5 passenger load	$-0.25 \pm 0.5$
	Caster	No passenger load	$2.8 \pm 0.5$	
		5 passenger load	$3.4 \pm 0.5$	
Shock absorber type		Double acting type		
Stabilizer type		Torsion bar type		
Rear	Suspension type		5 link rigid axle, Leaf spring*	
	Shock absorber type		Double acting type	

\* Specification for van/15 seats.

## SPECIAL TOOLS

OK201 341 AA0 Coil spring compressor 	For removing, installing coil springs	OK011 342 AA0 Rubber bushing replacer 	For removing, installing rubber bushing
OK710 342 017 Dust boot installer 	For installing tie rod boot	OK670 321 019 Ball joint remover 	For removing ball joint
OK130 283 021 Ball joint puller 	Tie rod and ball joints	OK710 331 009 Caster, camber gauge adapter 	For gauge adapter
OK990 283 025 Dust boot installer 	For installing dual boot		



# BODY

60

BACK DOOR .....	60- 5
BONNET .....	60- 3
DOOR MIRROR .....	60-18
FRONT BUMPER .....	60- 4
FRONT DOOR .....	60- 6
INSTRUMENT PANEL .....	60-13
POWER DOOR LOCK SYSTEM .....	60-20
POWER WINDOW SYSTEM .....	60-22
REAR BUMPER .....	60- 5
SEAT .....	60-14
SLIDE DOOR .....	60- 7
SUNROOF .....	60-23
WINDSHIELD WIPER AND WASHER .....	60- 9

## BONNET

### REMOVAL/INSTALLATION

1. Remove in the order as shown in the figure.
2. Install in the reverse order of removal.

#### Caution

- Remove the bonnet with another person for secure safety.

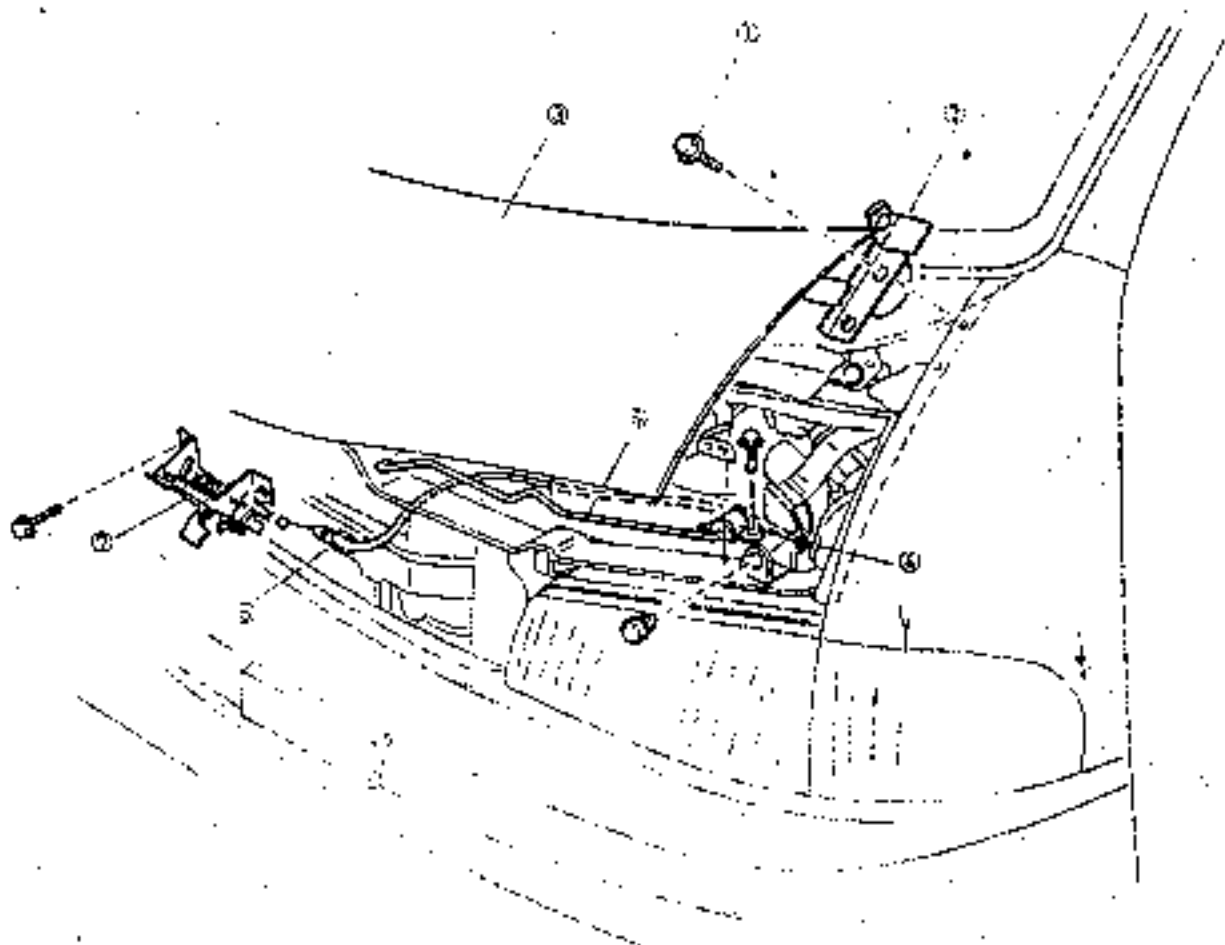

1. Bolt
2. Bonnet hinge
3. Bonnet
4. Bonnet stay holder

5. Bonnet stay
6. Release wire
7. Bonnet lock

ANP060001

## FRONT BUMPER

## REMOVAL/INSTALLATION

1. Remove the combination lamp and the head lamp.
2. Remove in the order as shown in the figure.
3. Install in the reverse order of removal.

## Note

- When installing, use new fasteners.

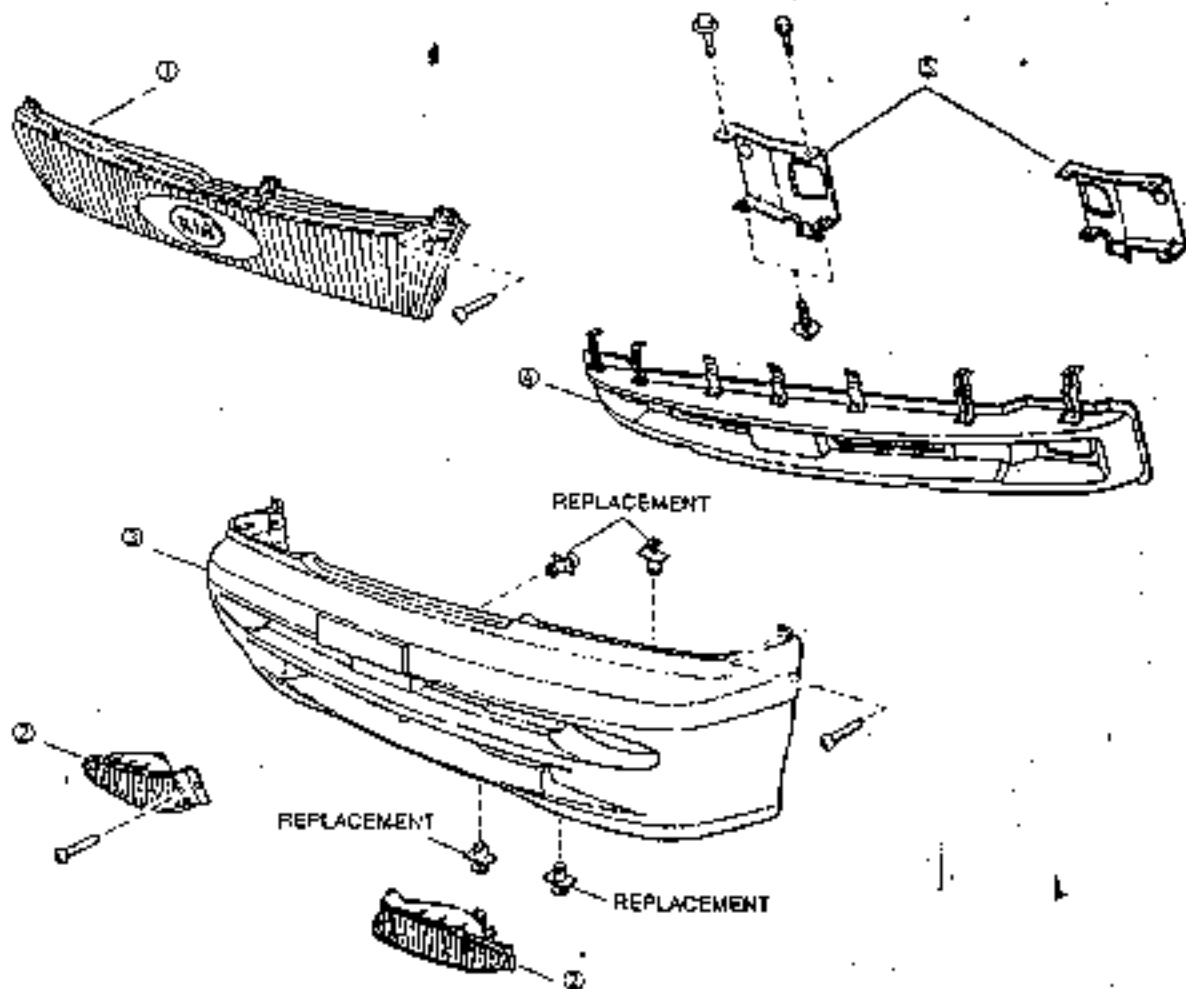

1. Dummy grill lamp
2. Fog lamp
3. Bumper face

4. Reinforcement
5. Bumper stay

## REAR BUMPER

## REMOVAL/INSTALLATION

1. Disassemble in the order as shown in the figure.
2. Install in the reverse order of removal.

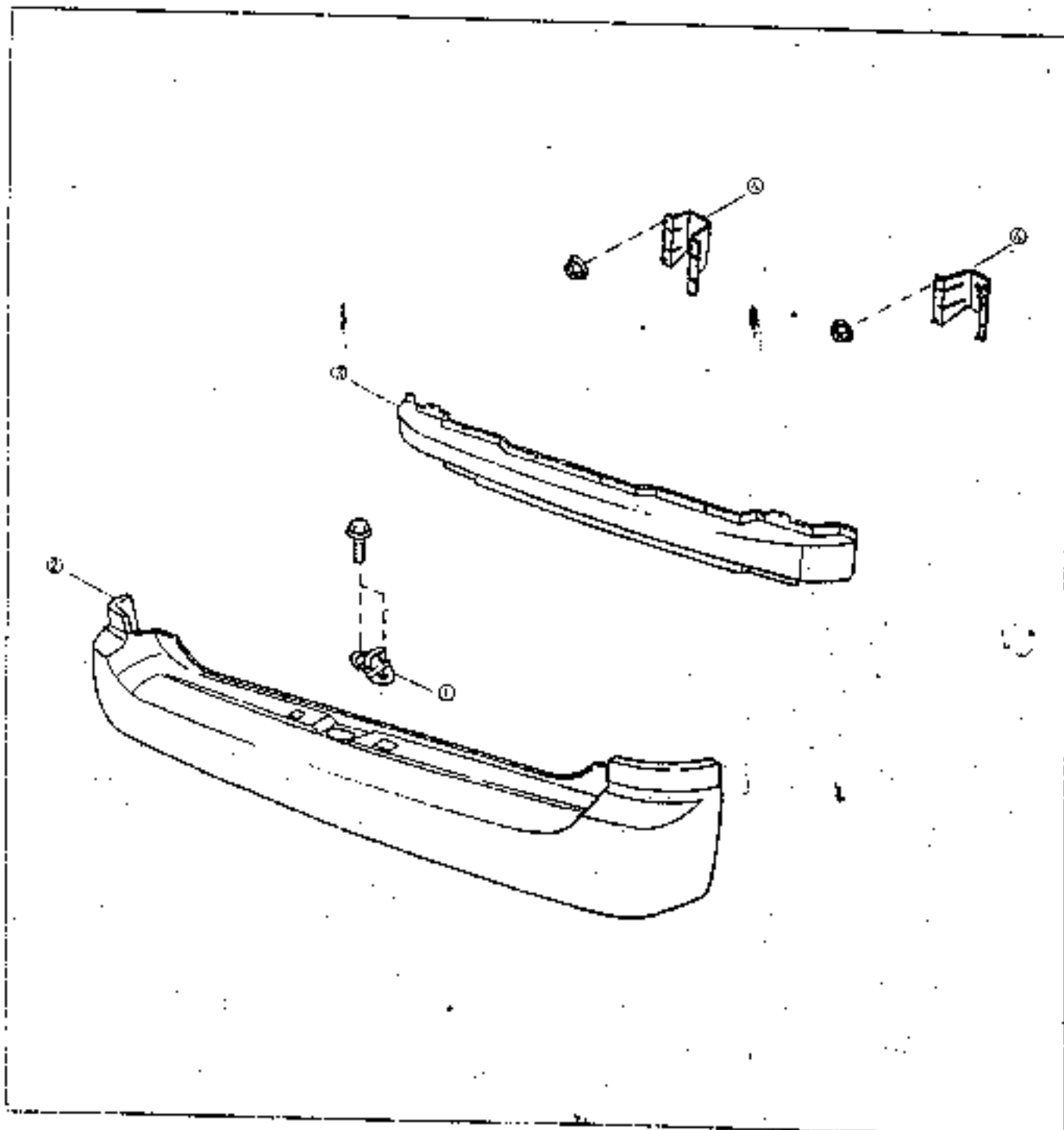

1. Back door striker
2. Bumper face

3. Reinforcement
4. Bumper slay

AN900003

## FRONT DOOR

## REMOVAL/INSTALLATION

1. Remove in the order as shown in the figure.
2. Install in the reverse order of removal.

**Caution**

- Remove the screen carefully to use again.
- Apply grease to the checker slide part before installing.

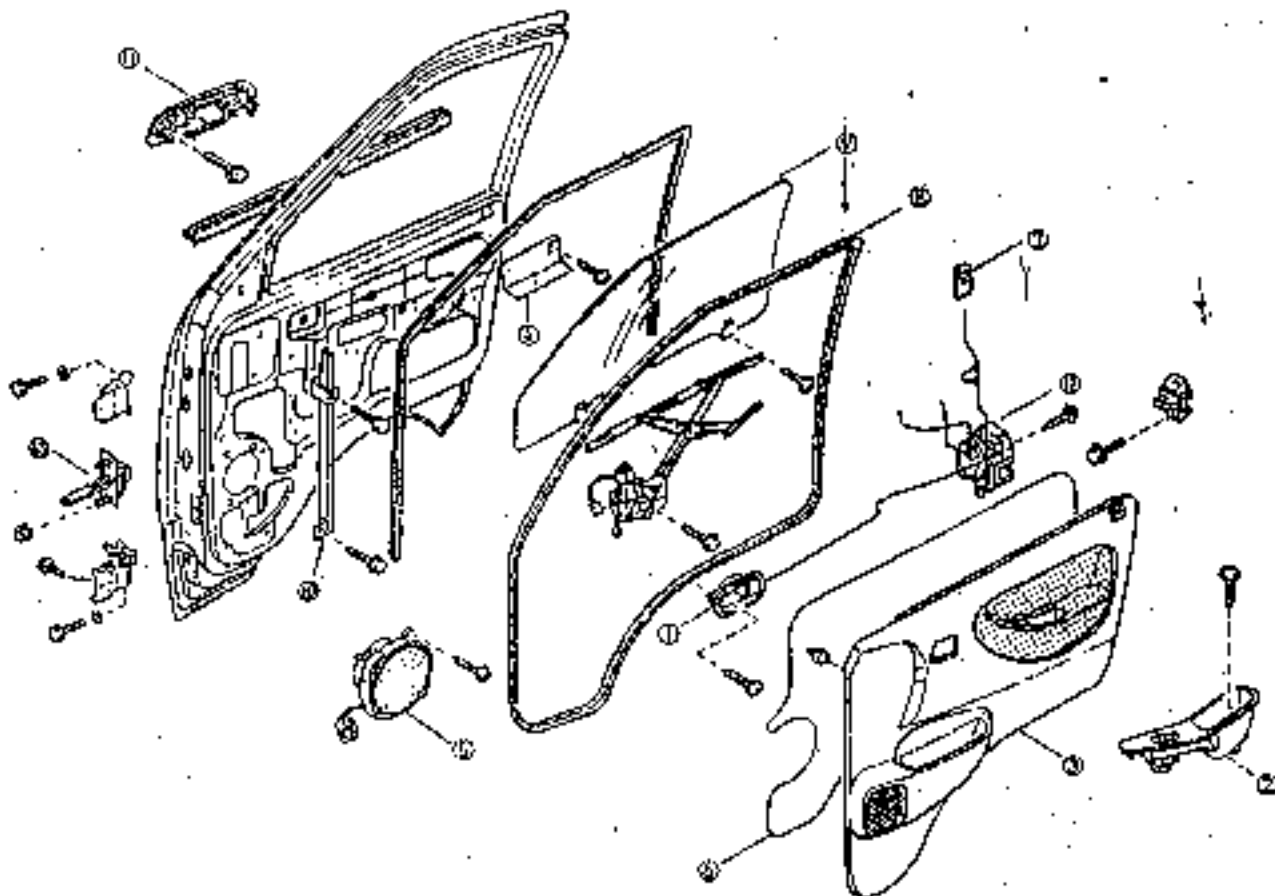

1. Inner handle
2. Door pull handle
3. Door trim
4. Pull handle bracket
5. Speaker
6. Screen
7. Door lock knob

8. Weatherstrip
9. Glass
10. Glass guide
11. Outer handle
12. Door lock assembly
13. Checker

AN6060034

## SLIDE DOOR

## REMOVAL/INSTALLATION

1. Install a jack under the slide door panel with a wooden block wrapped by cloth.
2. Remove in the order as shown in the figure.
3. Install in the reverse order of removal.

## Caution

- Remove the screen carefully to use again.

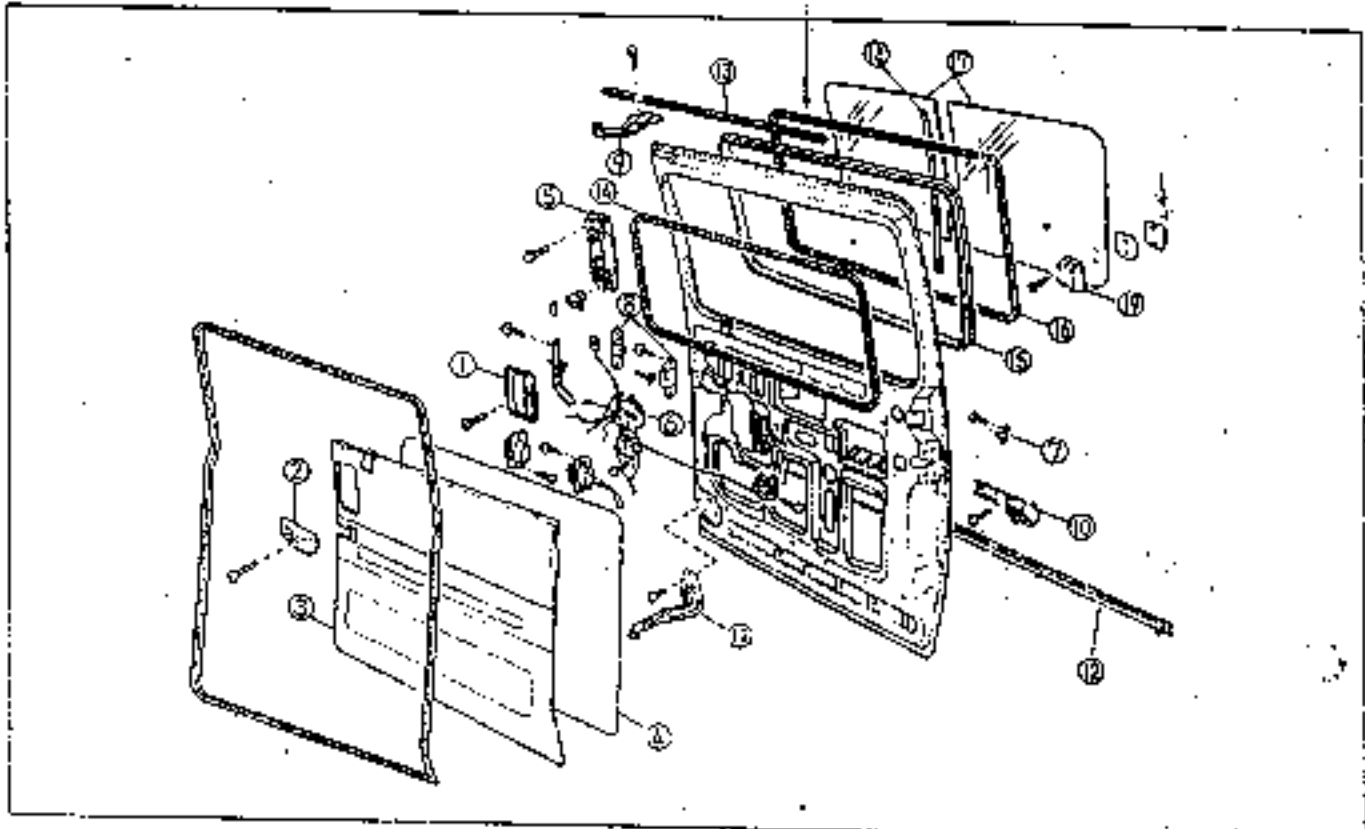

1. Inner handle
2. Pull open stopper
3. Door trim
4. Screen
5. Outer handle
6. Door lock and remote controller

7. Striker
8. Wedge and striker
9. Upper roller
10. Center roller
11. Lower roller
12. Center guide rail
13. Weatherstrip

14. Shimming well
15. Chassis
16. Glass run channel
17. Sliding glass
18. Center seal
19. Lock

## INSTALLATION NOTE

1. Apply grease to the frictional part.
2. Check the roller bearing for damage and operation.
3. Check and adjust the operating force of the door.
4. Check the standard clearance of door each part

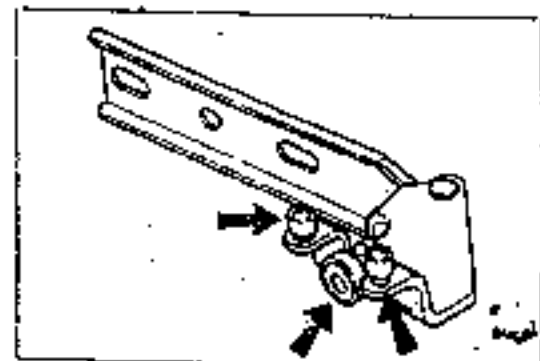

## BACK DOOR

## REMOVAL/INSTALLATION

1. Remove in the order as shown in the figure.
2. Install in the reverse order of removal.

## Caution

- Remove the screen carefully to use again.
- Work with another person for secure safety.

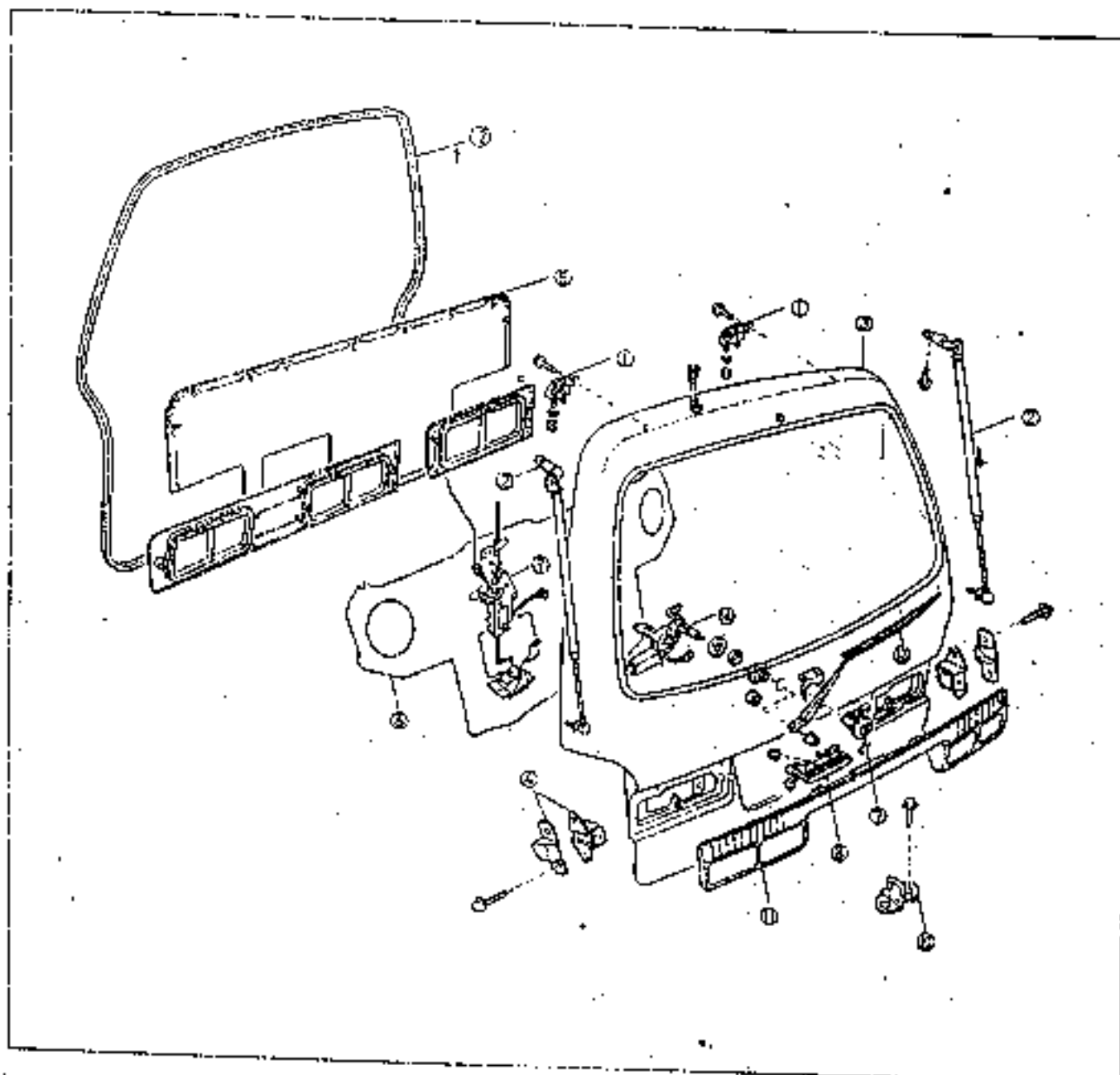

ANR060011

1. Hinge
2. Stay damper
3. Back door assembly
4. Dovetail and wedge
5. Door trim
6. Screen
7. Key cylinder

8. Outer handle
9. Door lock and remote controller
10. Striker
11. Back door garnish
12. Weatherstrip
13. Back door wiper arm and blade
14. Back door wiper motor

## WINDSHIELD WIPER AND WASHER

## REMOVAL/INSTALLATION

1. Remove in the order as shown in the figure.
2. Install in the reverse order of removal.
3. Check the wiper motor switch.

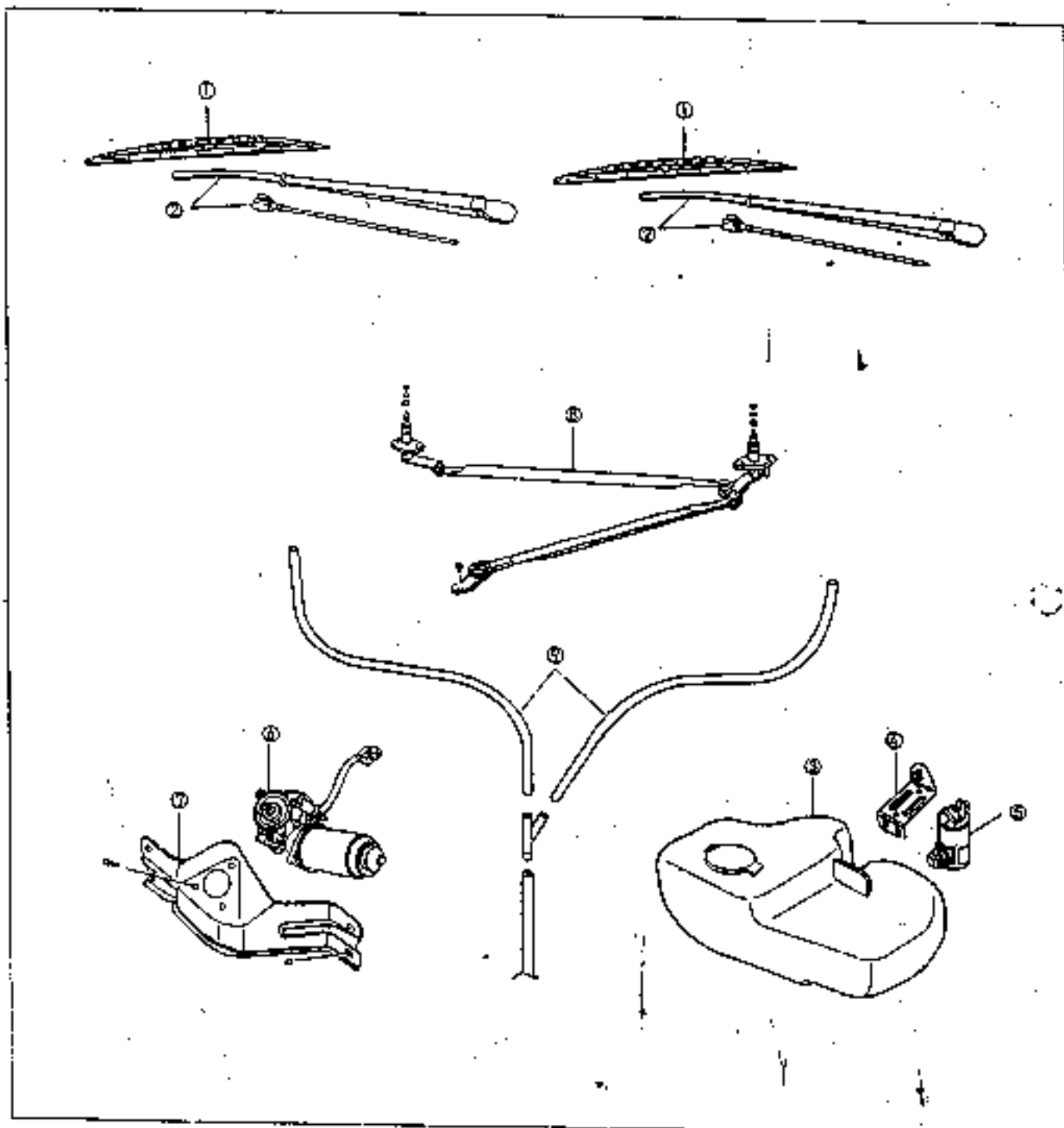

1. Wiper blade
2. Wiper arm and washer nozzle
3. Washer tank
4. Washer tank and bracket
5. Washer motor

6. Wiper motor
7. Wiper motor bracket
8. Wiper link
9. Washer hose



## WINDSHIELD WIPER AND WASHER (Only for RHD)

## REMOVAL/INSTALLATION

1. Remove in the order as shown in the figure.
2. Install in the reverse order of removal.
3. Check the wiper motor switch.

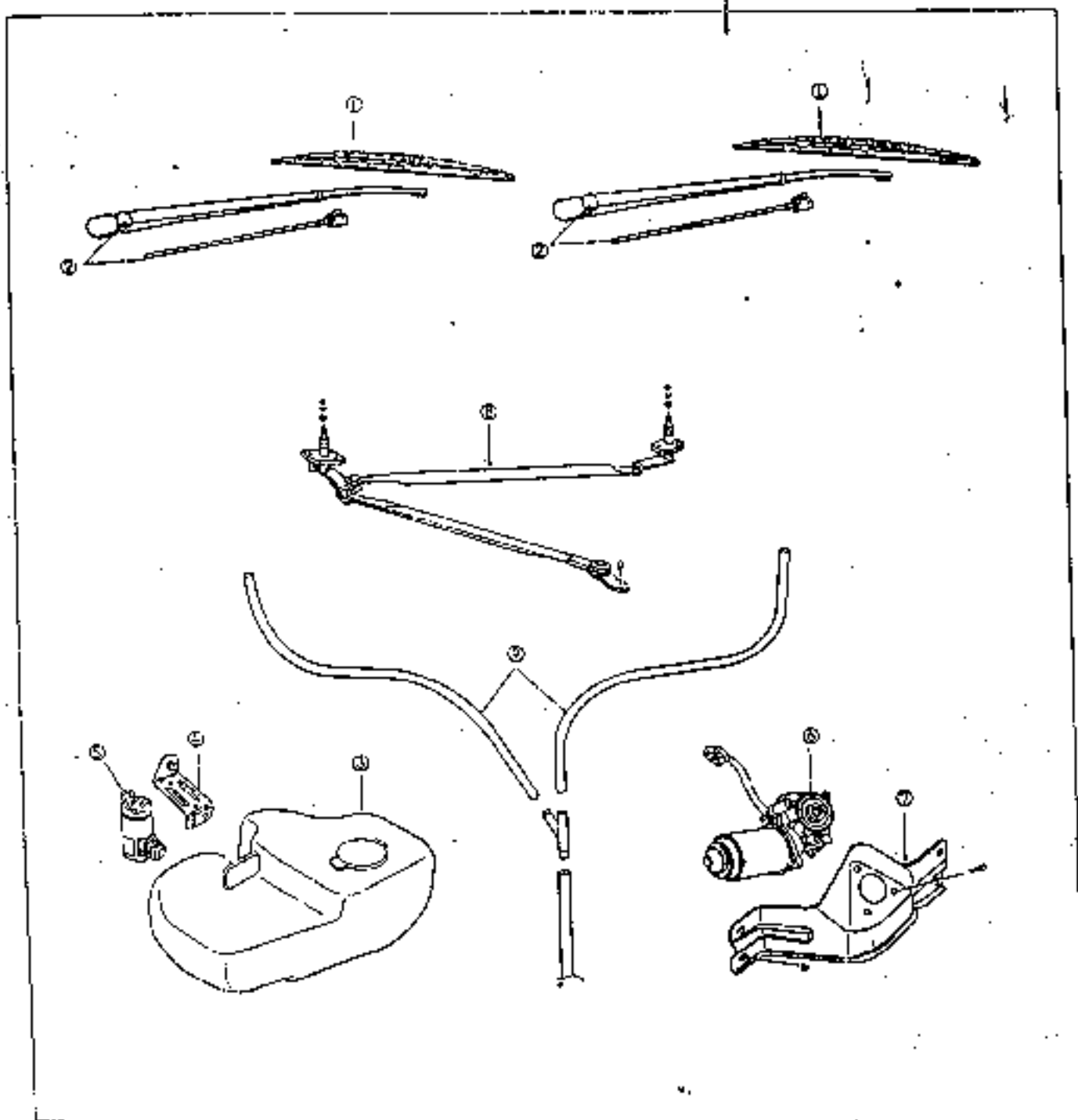

AN4060012

- |                                |                        |
|--------------------------------|------------------------|
| 1. Wiper blade                 | 6. Wiper motor         |
| 2. Wiper arm and washer nozzle | 7. Wiper motor bracket |
| 3. Washer tank                 | 8. Wiper link          |
| 4. Washer tank and bracket     | 9. Washer hose         |
| 5. Washer motor                |                        |



## INSTRUMENT PANEL

## REMOVAL/INSTALLATION

1. Remove in the order as shown in the figure.
2. Install it in the reverse order of removal.

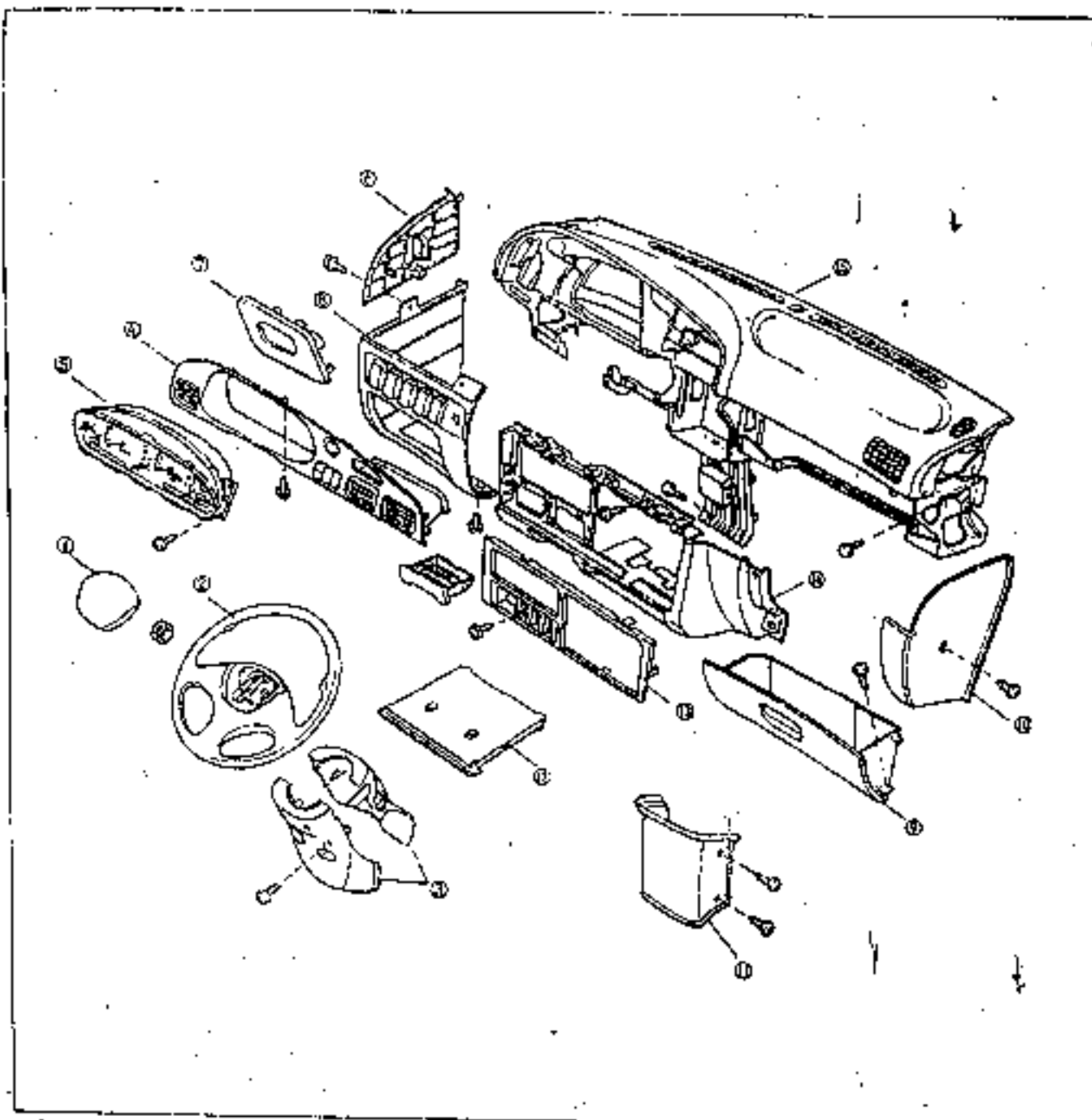

A749050018

1. Horn cap
2. Steering wheel
3. Column cover
4. Meter hood
5. Meter set
6. Side cover
7. Fuse box cover
8. Lower cover(LH)

9. Glove box
10. Lower cover(RH)
11. Center lower cover
12. Cup holder
13. Switch cover
14. Center panel
15. Instrument panel

## INSTRUMENT PANEL (Only for RHD)

## REMOVAL/INSTALLATION

1. Remove in the order as shown in the figure.
2. Install it in the reverse order of removal.

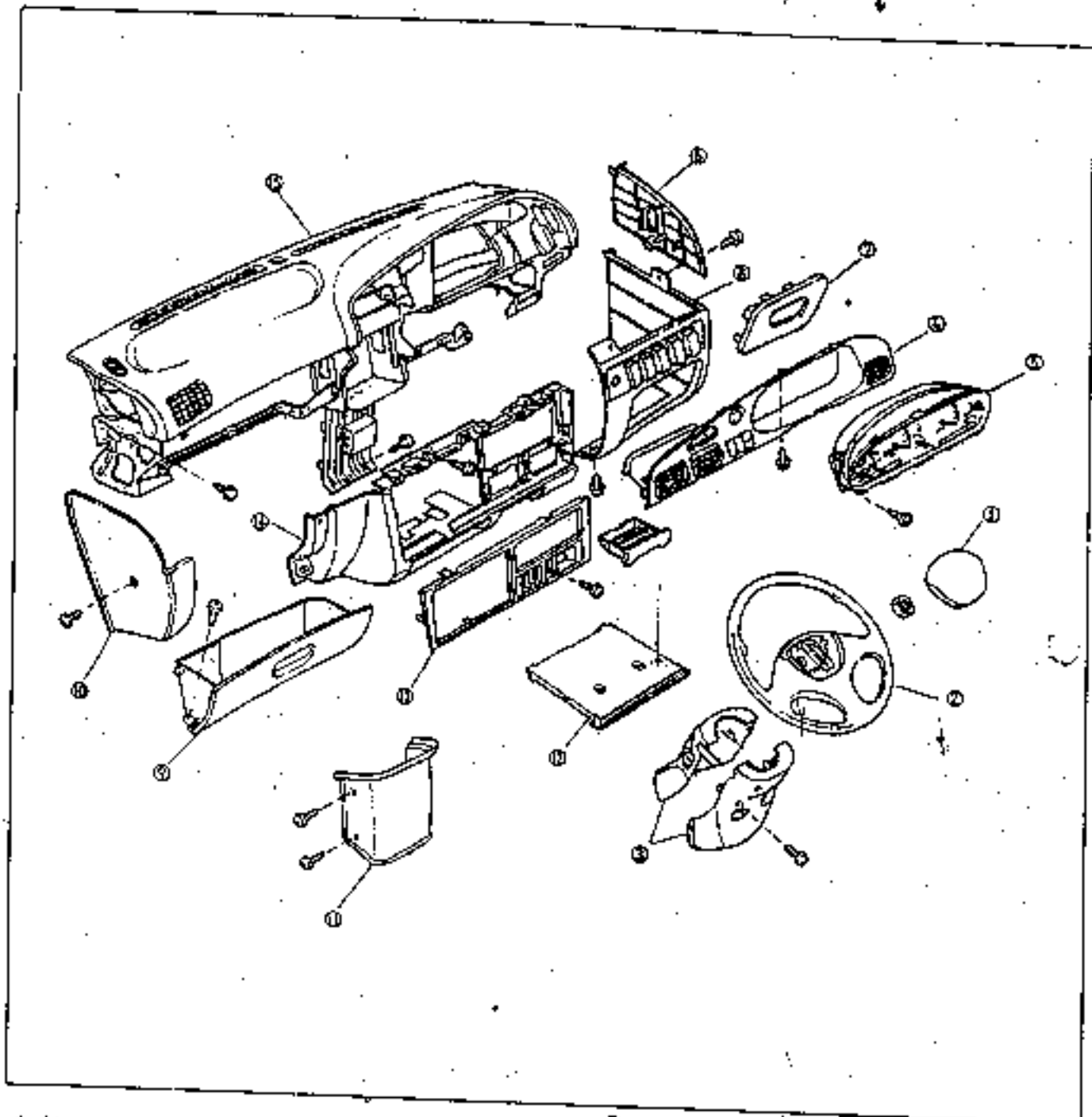

1. Horn cap
2. Steering wheel
3. Column cover
4. Meter hood
5. Meter set
6. Side cover
7. Fuse box cover
8. Lower cover(LH)

9. Glove box
10. Lower cover(RH)
11. Center lower cover
12. Cup holder
13. Switch cover
14. Center panel
15. Instrument panel

AN6080018-1



## REAR SEAT

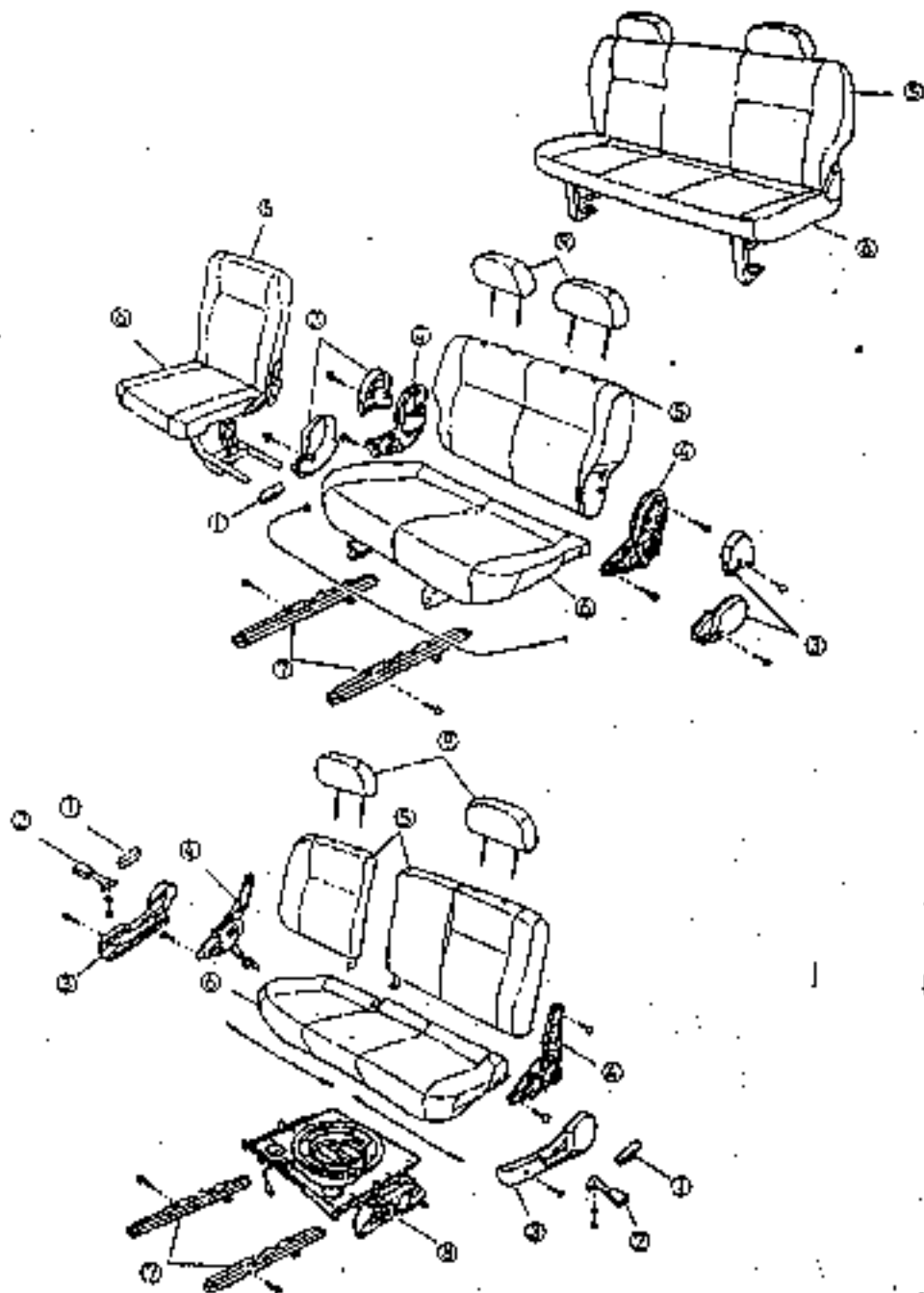

1. Knob
2. Turn lever
3. Side cover
4. Reclining nuckle
5. Seat back

6. Cushion
7. Seat adjust
8. Turn base
9. Head rest

## SEAT (Only for RHD)

### FRONT SEAT

#### Removal/Installation

1. Remove in the order as shown in the figure.
2. Install it in the reverse order of removal.

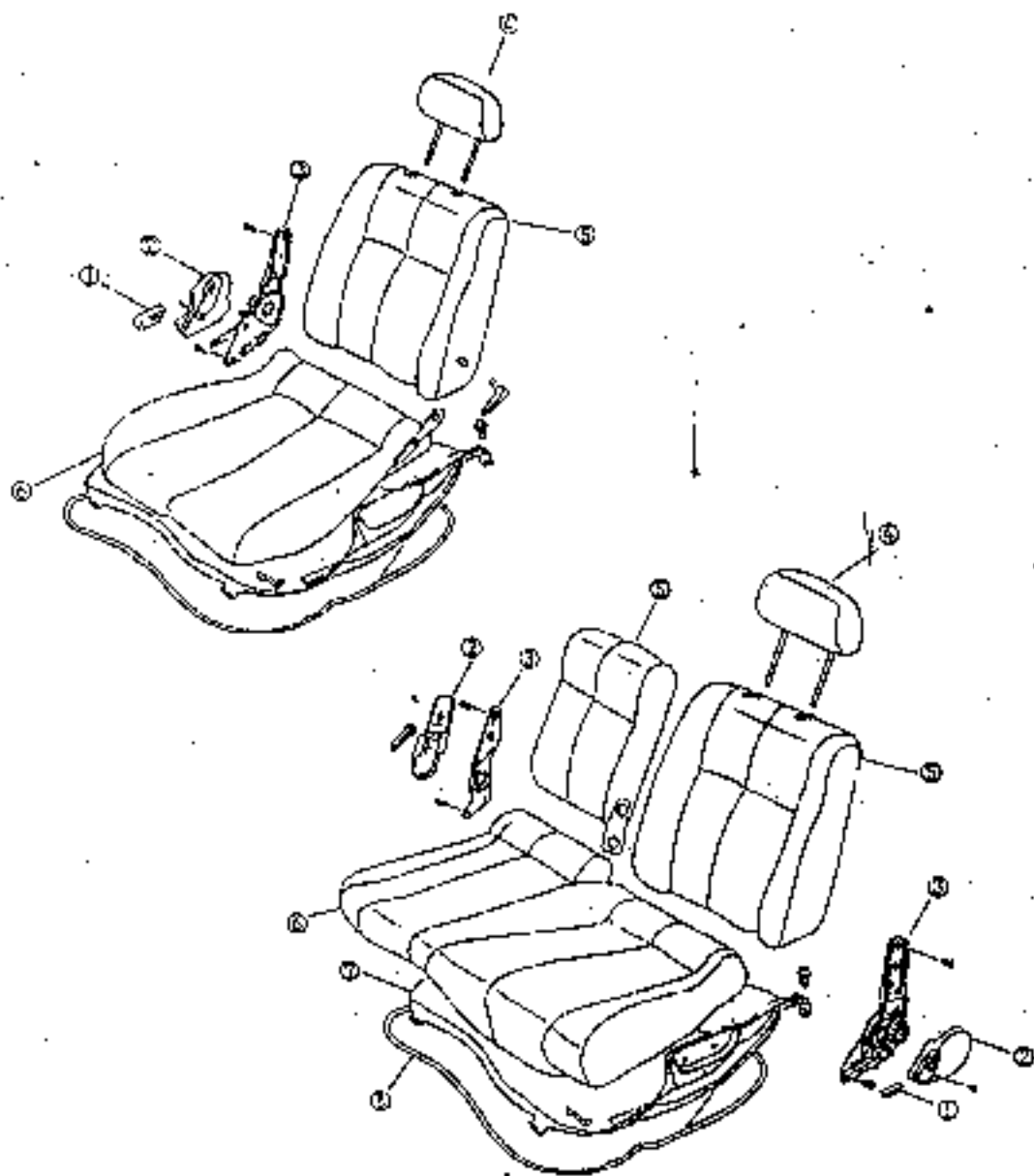

1. Knob
2. Cover
3. Reclining nuckle
4. Head rest

5. Seat back
6. Seat cushion
7. Seat under cover
8. Seal

AH9050017-1

## REAR SEAT

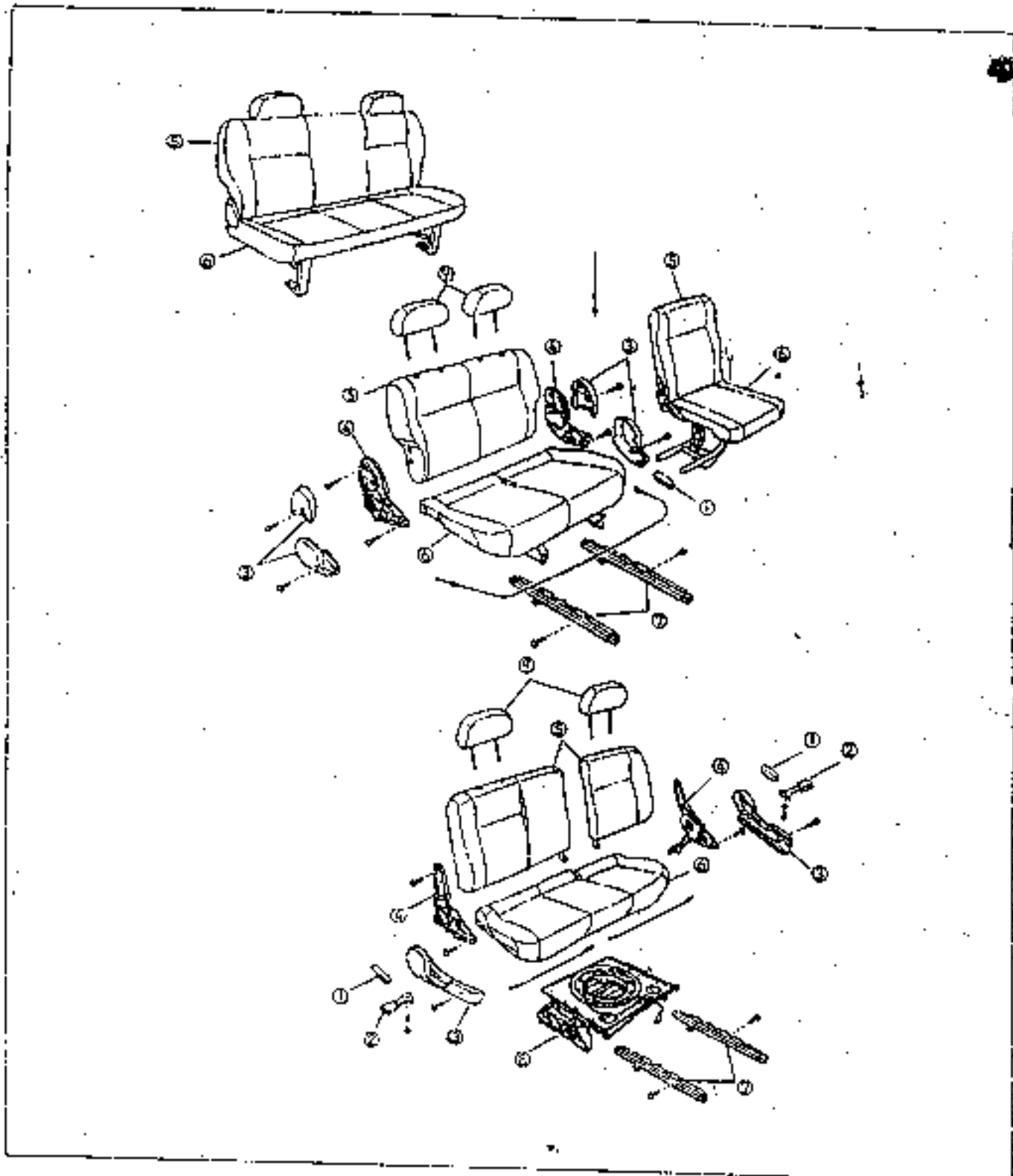

1. Knob
2. Turn lever
3. Side cover
4. Reclining nuckle
5. Seat back

6. Cushion
7. Seat adjust
8. Turn base
9. Head rest

AH180400210-1



## DOOR MIRROR

## REMOVAL/INSTALLATION

1. Remove in the order as shown in the figure.
2. Install it in the reverse order of removal.

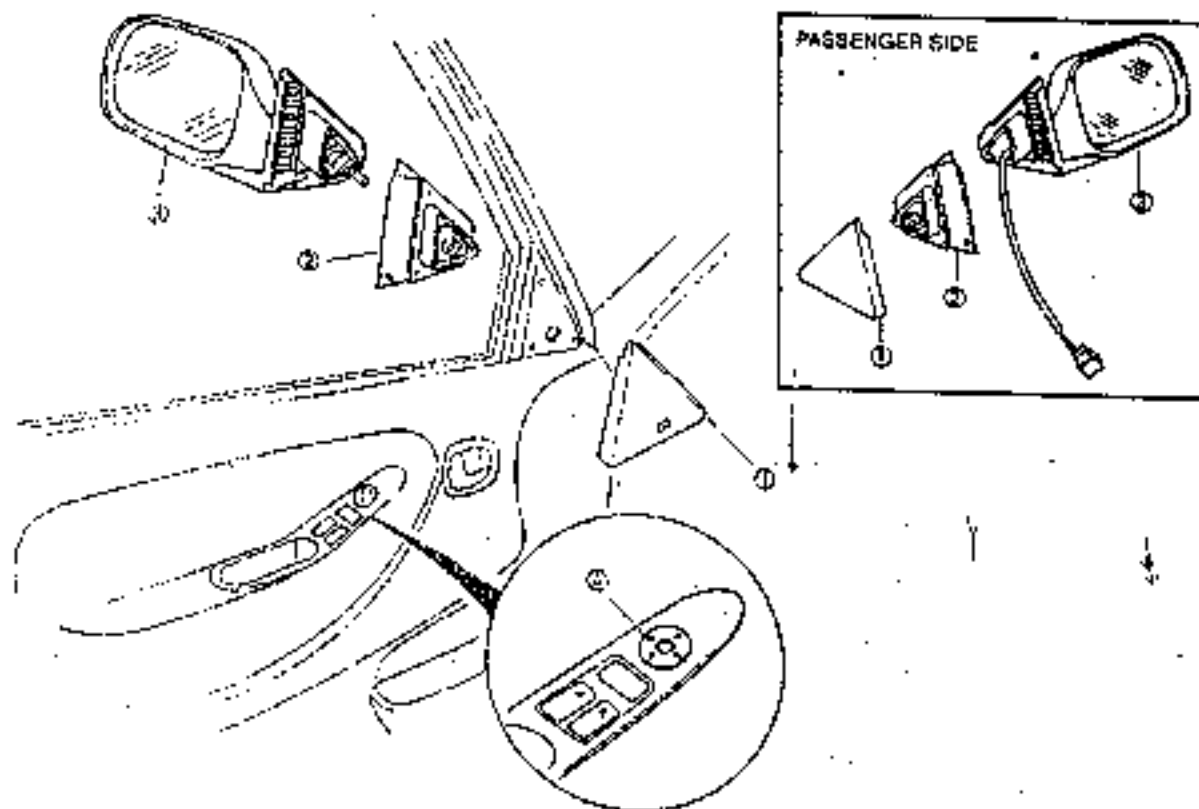

1. Inner garrish
2. Seal

3. Door mirror
4. Remote controller switch

## INSPECTION

## Remote control mirror

1. Check if current passes between the battery terminals by an ohmmeter.

Terminal		5	1	4	2	6	⊕	⊖
Remote mirror	up		○				○	
	down		○	○				○
	left	○		○			○	
	right	○		○			○	
Heater	—		○	○	○	○		

○—○ : continuity

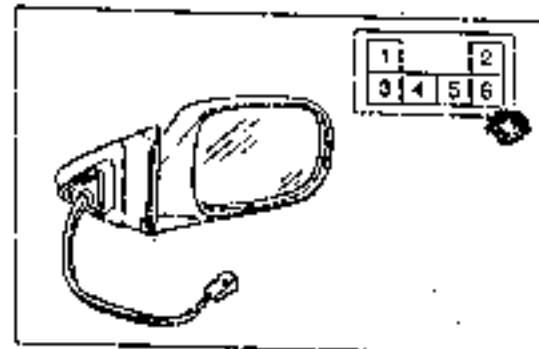

A170050029

## Remote control mirror switch

1. Disconnect the remote control mirror switch.
2. Check if current passes between the battery terminals by an ohmmeter.

Terminal		3	2	6	7	4	1	5
Passenger side	up	○				○		
	down	○	○					○
	left	○				○		○
	right	○		○				○

○—○ : continuity

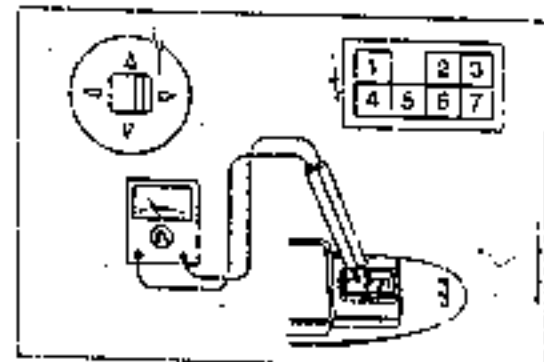

A170060021

POWER DOOR LOCK SYSTEM

STRUCTURAL VIEW

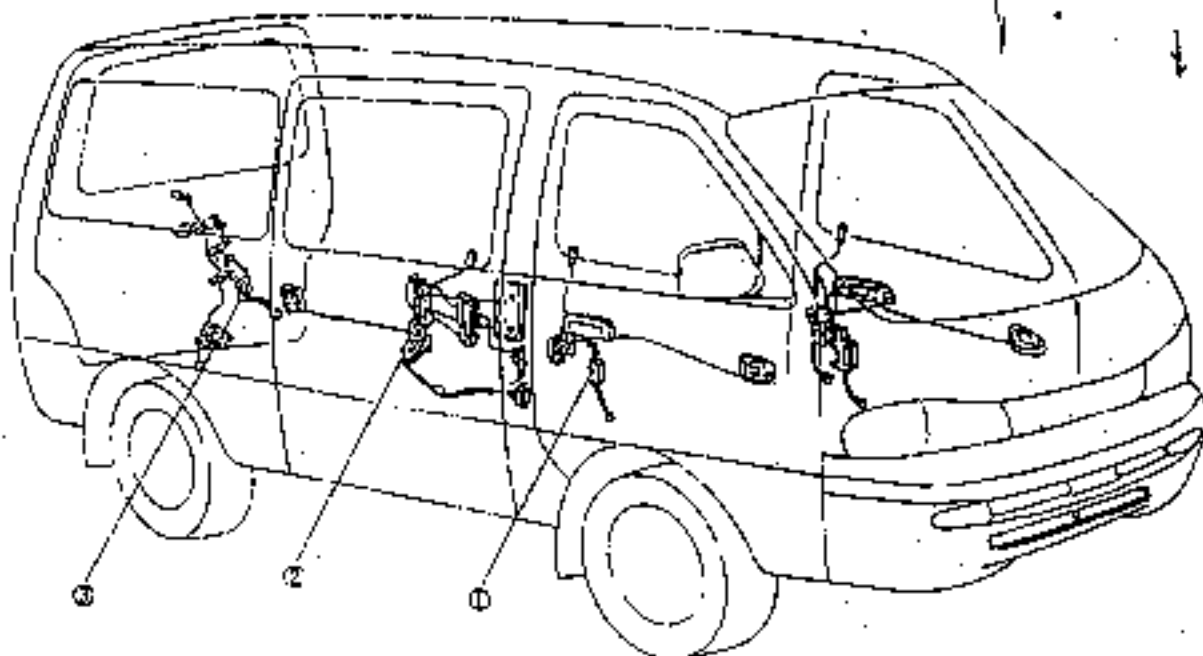

- 1. Front door lock
- 2. Slide door lock controller

- 3. Back door lock controller

POWER DOOR LOCK SYSTEM (Only for RHD)

STRUCTURAL VIEW

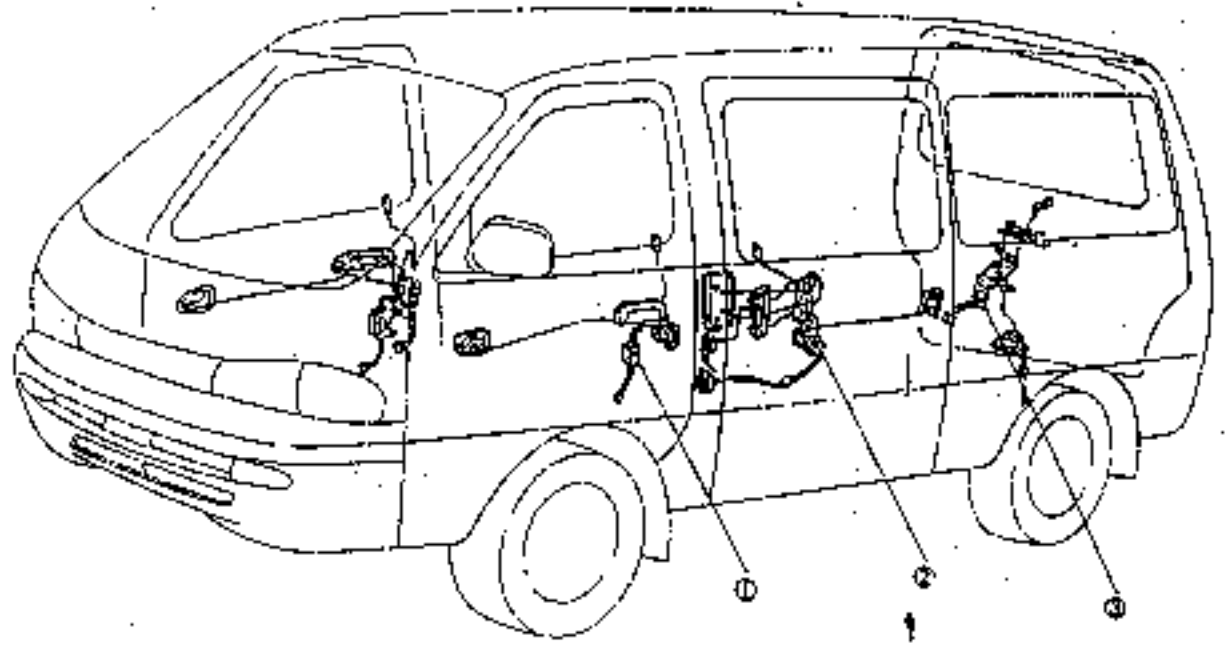

- 1. Front door lock
- 2. Slide door lock controller

- 3. Back door lock controller

POWER WINDOW SYSTEM

STRUCTURAL VIEW

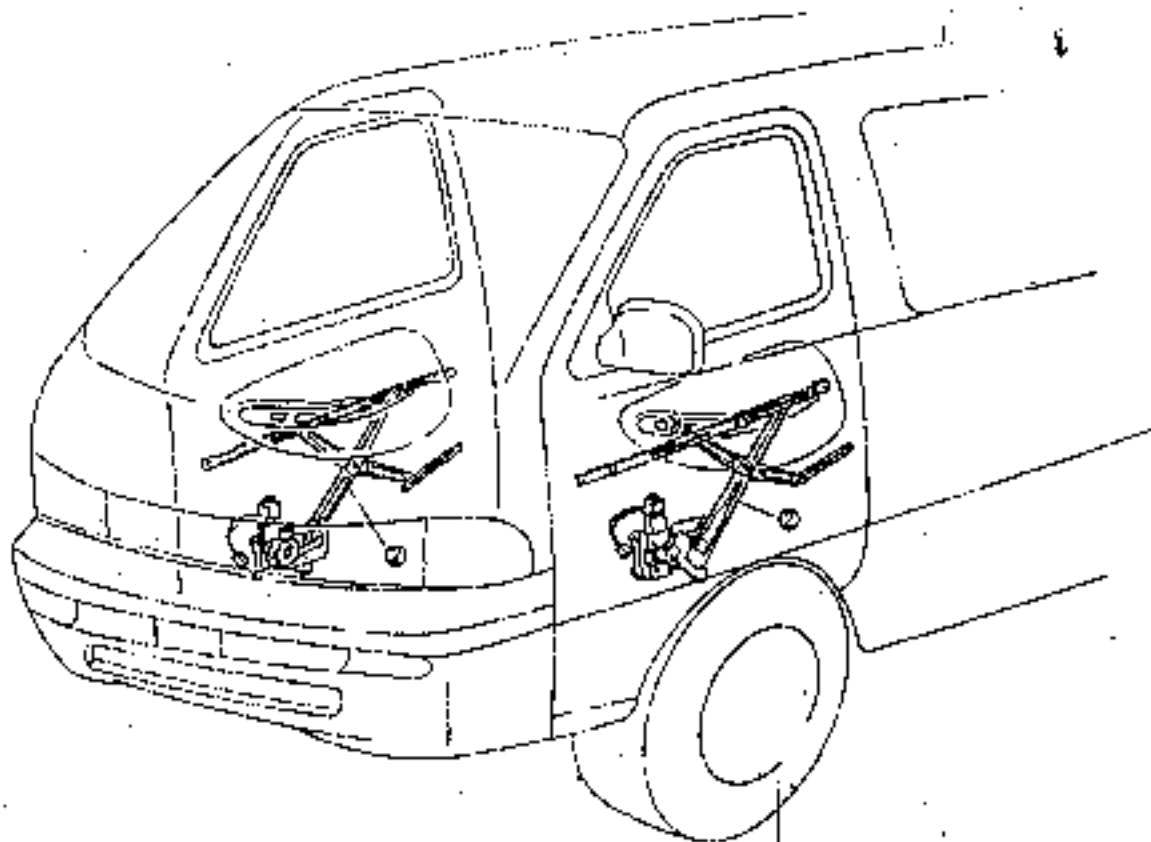
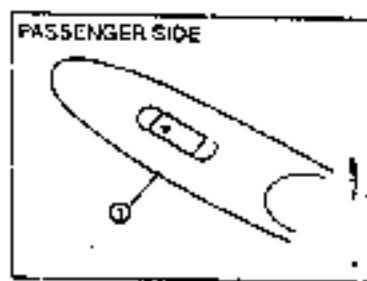
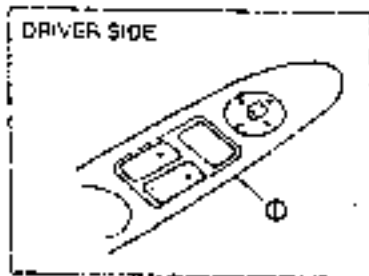

1. Power window switch

2. Power window regulator

ANP060023

## SUNROOF

## REMOVAL/INSTALLATION

1. Remove each pillar trim.
2. Remove it in the order as shown in the figure.
3. Install it in the reverse order of removal.

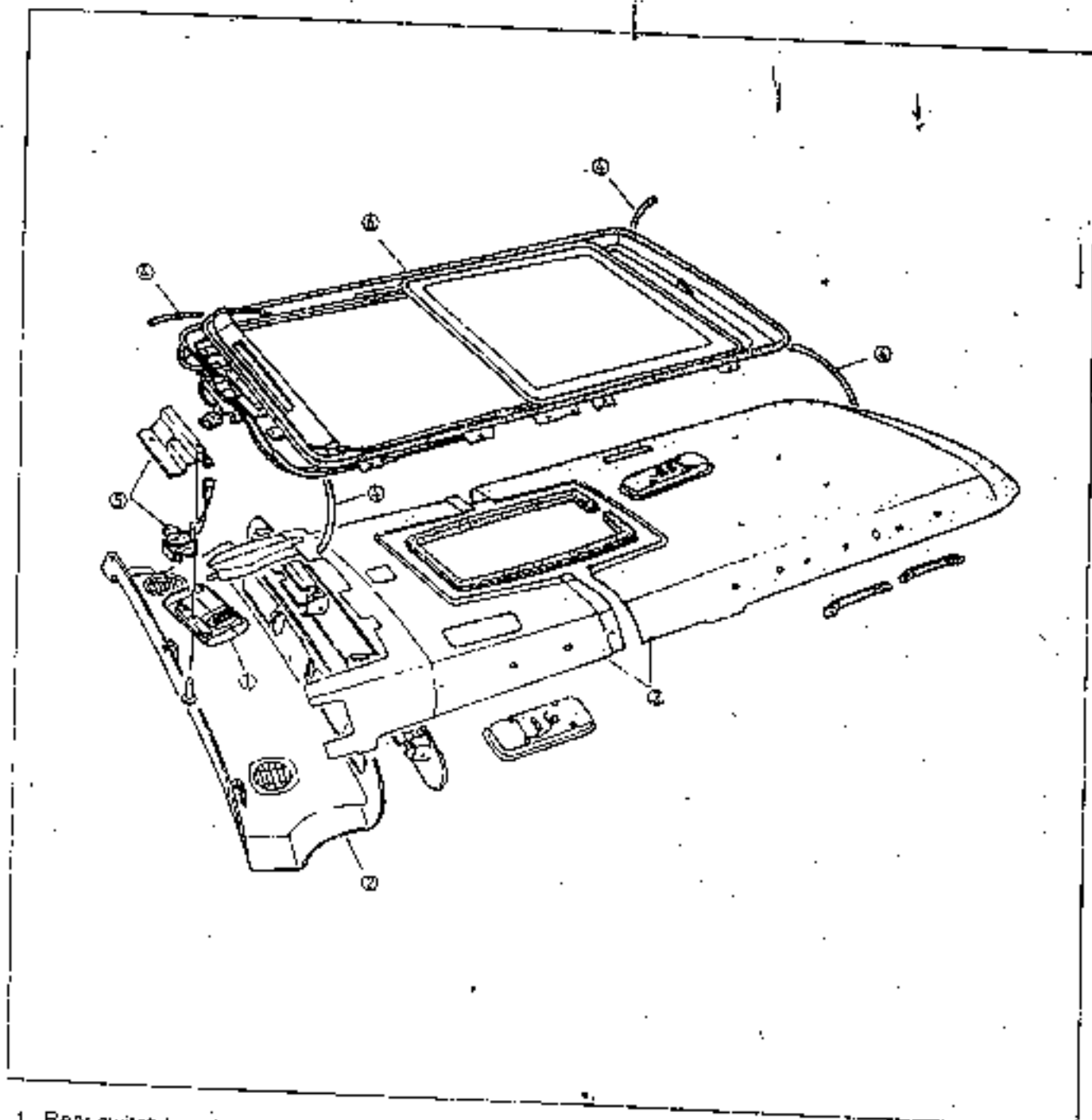

1. Rear switch bezel
2. Aircon system cover
3. Top sealing

4. Drain hose
5. Rear switch and bracket
6. Sliding sunroof assembly

A410260024

## INSPECTION

1. Inspection for the friction resisting force of the roof lid glass  
After removing the sunroof motor, check the friction resisting force of the roof lid glass as follows.
  - (1) Remove the top ceiling.
  - (2) Remove the decoration cover.
  - (3) Tie a wire at the front of the roof lid glass installation nuts.
  - (4) Remove the motor with the roof lid glass open.
  - (5) Measure the friction resisting force of the roof lid glass by a spring balancer.

Standard : 218 N (22 kg, 48 lb)

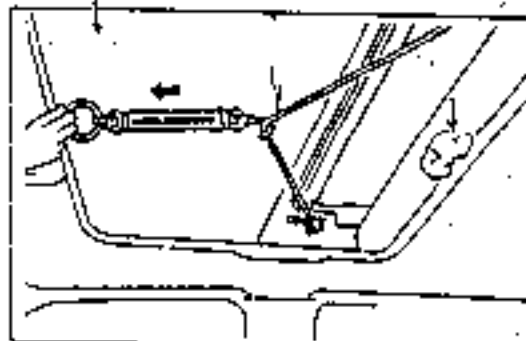

AN9060026

- (6) If the friction resisting force of the roof lid glass is above the standard, check the followings.
  - assembled status of the sunroof assembly, deformation and inclusion of foreign material
  - stuck drive cable
  - inclined roof lid glass

2. Inspection for the sliding force of the sunroof motor clutch.
  - (1) After inserting the emergency handle into the hexagonal hole of the motor drive shaft, install a gauge as shown in the figure.
  - (2) After connecting battery power source between the connector terminals 1 and 3 of the sunroof motor, rotate the motor.
  - (3) Measure the load of the pull scale when the rotating force of the sunroof motor and the tensile force are balanced.

Standard : 29~59 N (3~6 kg, 22~44 lb)

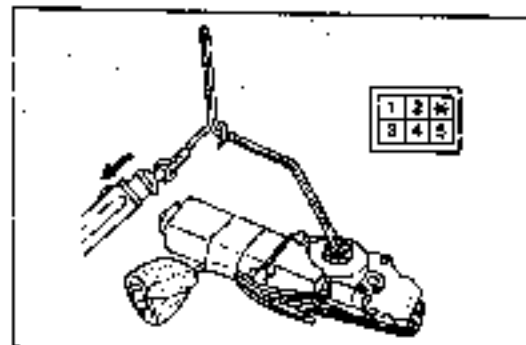

AN9060028

## Caution

- Maintain the pull scale in a direction perpendicular to the emergency handle.
- If the emergency handle other than the one provided in the vehicle is used, the sliding force of the clutch may change that be sure to use the one provided in the vehicle.
- If the sliding force of the clutch is out of the standard, replace the sunroof motor.

3. Inspection for the sunroof motor.  
Check the rotating direction of the drive gear when the battery is connected to the connector terminals.

Rotating direction of the drive gear	Battery connecting terminals	
	1	3
Clockwise	⊖	⊕
Counterclockwise	⊕	⊖

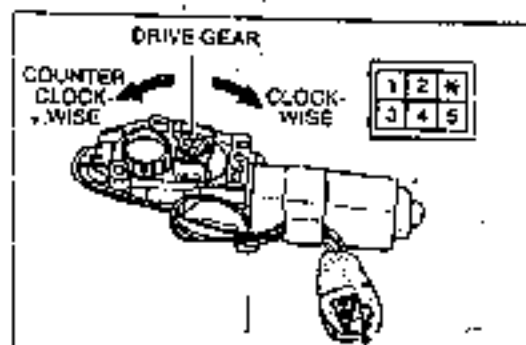

AN9060027

## SPECIFICATIONS

Items		Specifications	Coach	Van
Cooling capacity	Maximum cooling	Front evaporator (Kcal/h)	1100	0
		Rear evaporator (Kcal/h)	3360	0
	Air flow	Front evaporator (m <sup>3</sup> /h)	450	0
		Rear evaporator (m <sup>3</sup> /h)	400	0
	Power consumption	Front motor (W-V)	218-12	0
		Rear motor (W-V)	168-12	0
Heating capacity	Maximum heating	Front heater (Kcal/h)	4800	0
		Rear heater (Kcal/h)	4100	0
	Blower capacity	Front heater (m <sup>3</sup> /h)	350	0
		Rear evaporator (m <sup>3</sup> /h)	270	0
	Power consumption	Front heater (W-V)	218-12	0
		Rear heater (W-V)	168-12	0
Air Con components	Compressor	Type	Webbex-plate type	0
		Outlet flow (cc/rev)	179	0
		Number of cylinder	7	0
		Maximum speed (rpm)	6000	0
		Oil (capacity) (cc)	See pag 56(25)	0
	Magnetic clutch	Type	Magnetic	0
	Main condenser	Power consumption (W-V)	43-12	0
		Type	Parallel flow type	0
		Heat dissipation (Kcal/h)	1500	0
	Sub condenser	Blower capacity (m <sup>3</sup> /h)	1450	0
		Type	Parallel flow type	0
		Heat dissipation (Kcal/h)	600	0
	Front evaporator	Blower capacity (m <sup>3</sup> /h)	500	0
		Type	Laminated type	0
		Expansion valve	Block type	0
		Thermostat (OFF (°C)) (For defroster) ON (°C)	0.5	0
	Rear evaporator	Type	1	0
		Expansion valve	Fin and tube type	0
	Recoiler drier	Drier	Uniform internal pressure type	0
	Dual pressure switch (kg/cm <sup>2</sup> G)	High pressure	OFF (kg/cm <sup>2</sup> )	ZEOLITE (XH-8)
ON (kg/cm <sup>2</sup> )			92 ± 2	0
Low pressure		OFF (kg/cm <sup>2</sup> )	5 ± 2	0
		ON (kg/cm <sup>2</sup> )	2.0 ± 0.2	0
Heater component	Heater core	0.25	0	
	Modulator	Aluminum type tube	0	
Pressure of refrigerant	High pressure side (kg/cm <sup>2</sup> )	Electric drive	0	
	Low pressure side (kg/cm <sup>2</sup> )	13.0-20	0	
Used refrigerant (charged amount)			1.5-2.5	0
			R-134a (12 seats coach: 1150)	0
			R-134a (15 seats coach: 1300)	0
		R-134a (Van 800)	0	



4. Check for current passing of the limit switch.  
 (1) After removing the limit switch from the motor, operate and check it.

Switch operating condition	Terminals				
	1	2	3	4	5
ON		G		Q	
OFF					

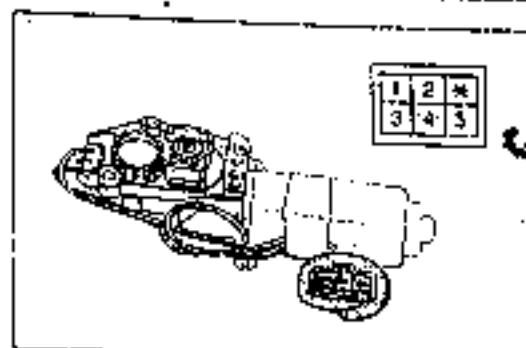

AN9060328

5. Check for current passing of the sunroof switch. (for front seat)

Switch condition		Terminals		
		1	2	3
For front seat	Open		○	○
	Close	○	○	
For rear seat	Open	○	○	
	Close		○	○

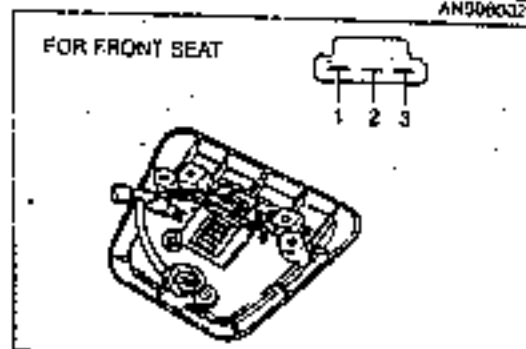

AN9060329

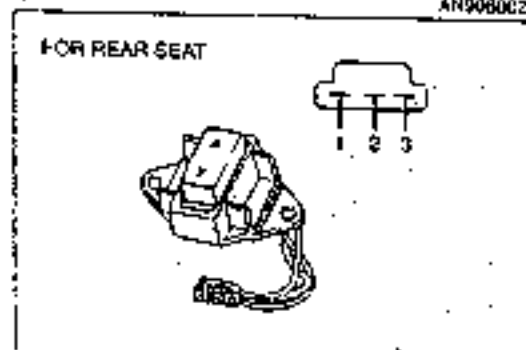

AN9060330

# BODY ELECTRICAL SYSTEM

61

EXTERIOR LIGHTING SYSTEM .....	81- 6
HORN .....	81-10
WARNING LAMP .....	81-21
INTERIOR LIGHTING SYSTEM .....	81- 6
INSTRUMENT PANEL(METERS) .....	81-15
KEYLESS ENTRY SYSTEM .....	81-24
MAIN FUSE AND FUSE .....	81- 5
OUTLINE .....	81- 3
REAR WINDOW DEFROSTER .....	81-11
SWITCH: .....	81- 8
TIMER CONTROL UNIT .....	81-12

OUTLINE

LAMP, RELAY, TCU, QSS CONTROL UNIT, HORN MOUNTING POSITIONS

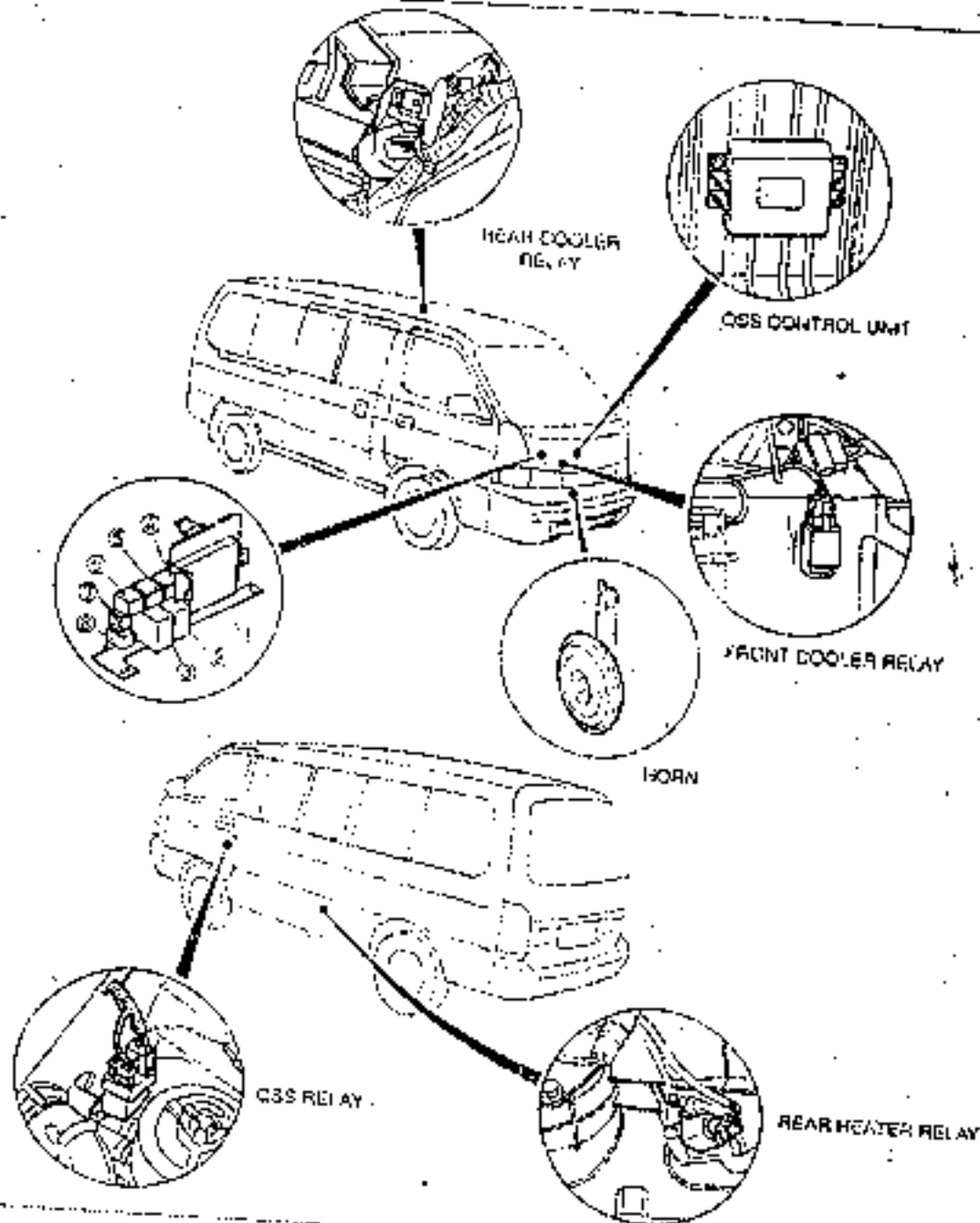

Lamp specifications

Lamp	Front side		Lamp	Rear side	
	Quantity	Capacity (W)		Quantity	Capacity (W)
Head lamp	2	50/55	Turn signal	2	27
Fog lamp	2	27	Marker side lamp	2	5
Position lamp	2	5	Backup lamp	2	27
Turn signal	2	27	Back door stop lamp	2	27/8
			Tail lamp		
			Stop lamp	2	27/8
			Tail lamp		

No.	Name
1	Timer control unit
2	Hazard flasher unit
3	Intermittent wiper relay
4	Horn relay
5	Front heater relay
6	Rear defrost relay
7	Power window relay
8	ABS relay

SWITCH INSTALLATION POSITION

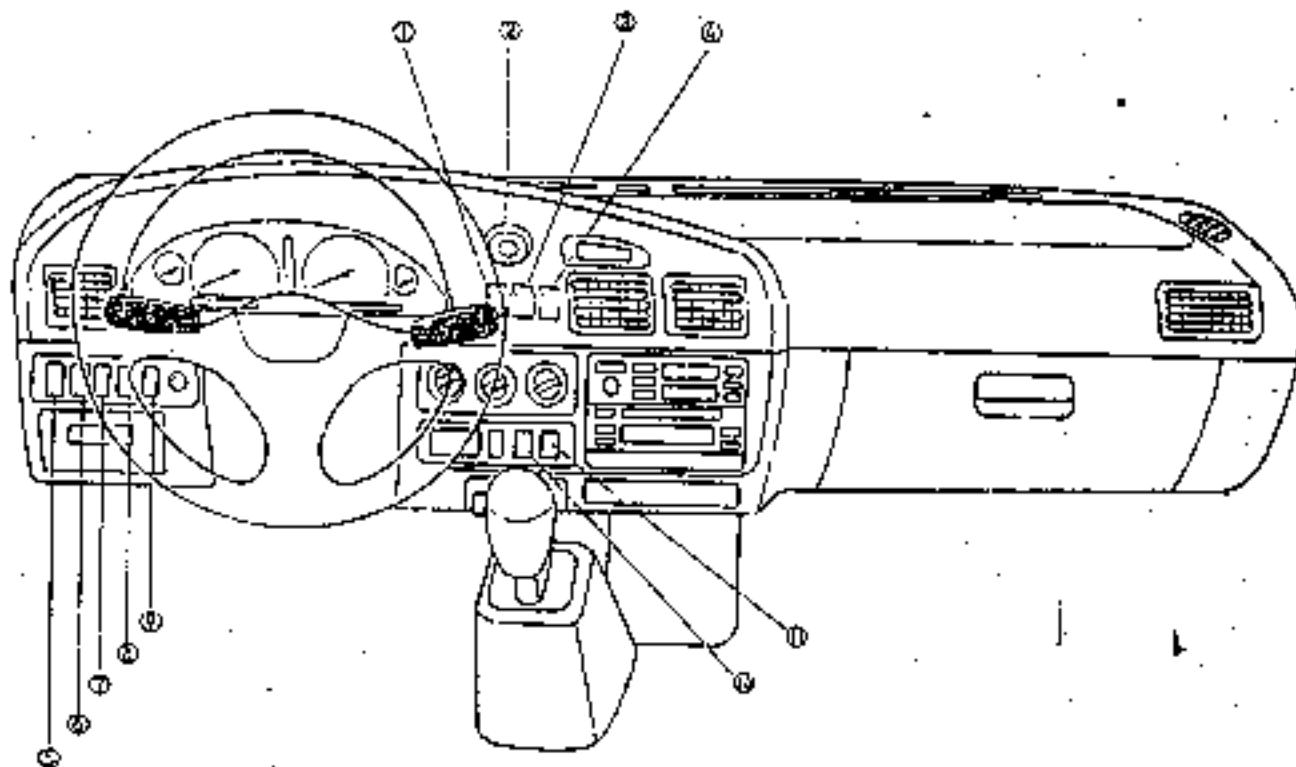

1. Rear wiper washer switch, (see section 60)
2. Hazard switch
3. Fresh, recirculation switch, (see section 62)
4. Front aircon main switch, (see section 62)
5. Rear room lamp switch.
6. Fog lamp switch.

7. Rear heater main switch, (see section 62)
8. Rear air conditioner main switch, (see section 62)
9. Side mirror defroster switch, (see section 60)
10. Rear defroster switch
11. EC-AT switch, (see section 42)

AN8061002

## MAIN FUSE AND FUSE

### DESCRIPTION

- The electric circuit of a vehicle is protected by the main fuses and fuses.
- The main fuse is located in the front of the battery which is in the right of the engine room.
- There are 5 main fuses in the main fuse box.
- 5 main fuses consist of glow (60A), main (30A), BTN (60A), heater (40A), and aircon (50A).
- The fuse box is located in the left bottom of the driver seat. The fuse is the cartridge type that use a special plug to replace it. Replace it with one of same capacity.
- To install it, match the fuse to the terminal (fuse box) and insert it straight.

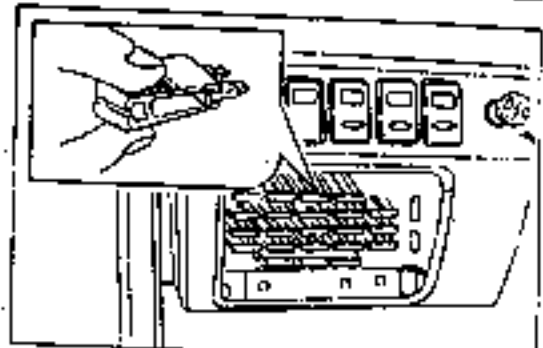

AN9001003

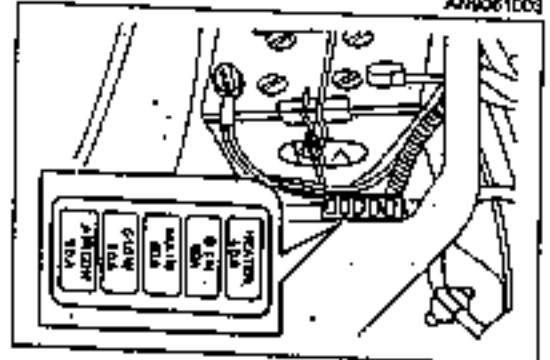

AN9001004

### FUSE CHART

Main fuse and fuse		Related circuits
Main (30A)	---	• Alternator / QSS / starter
	ABS (30A)	• ABS
	Head (30A)	• Head lamp
	Meter (10A)	• Meter set / EC-AT / turn hazard / backup lamp / rear defrost / sun roof / aircon & heater
	Engine (10A)	• QSS/EC-AT/ABS
	Wiper (15A)	• Wiper & washer / aircon & heater
	Radio (10A)	• Mirror defrost / power mirror / clock / audio
	Cigar (10A)	• Cigar lighter
Glow (60A)	---	• QSS
BTN (60A)	Defrost (20A)	• Power mirror / rear defrost
	Power window (30A)	• Power window
	Stop (20A)	• Stop lamp
	Sun roof (20A)	• Sunroof
	Room (15A)	• Room lamp / TCU / audio / clock / EC-AT / meter & warning lamp
	Door lock (30A)	• TCU
	Hazard (15A)	• Turn & Hazard
	Tail INT (15A)	• Turn & hazard / audio / clock / EC-AT / meter & warning lamp / cigar lighter / power mirror / aircon & heater
	Tail EXT (15A)	• position lamp / number plate lamp / tail lamp / fog lamp /
	Fog lamp (10A)	• Fog lamp
Aircon (50A)	Front aircon (30A)	• Aircon
	Rear aircon (20A)	• Aircon
Heater (40A)	Front heater (30A)	• Heater
	Rear heater (20A)	• Heater

### INTERIOR LIGHTING SYSTEM

#### DOOR SWITCH

##### Inspection

Check if current passes between the door switch terminals.

Status	Continuity
OFF	X
ON	O

O : continuity X : no continuity

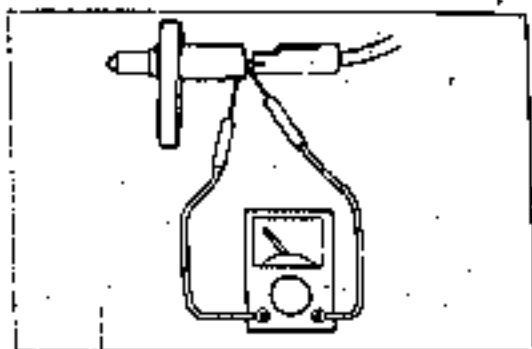

BSX081047

#### REAR ROOM LAMP SWITCH

##### Note

- The rear room lamp switch is installed at the left of the instrument panel.

1. Check if current passes between the switch terminals.

Status	Terminals					
	a	b	c	d	e	f
OFF	○	●				
ON				○	○	○

● : illumination lamp (1.4W)  
○—○ : continuity

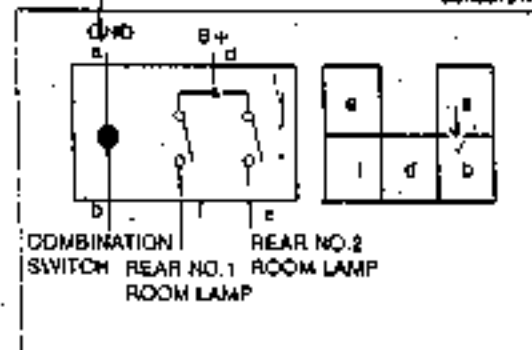

ANR061006

### EXTERIOR LIGHTING SYSTEM

#### STOP LAMP SWITCH

##### Inspection

- Disconnect the battery negative terminal.
- Disconnect the stop lamp switch connector.
- Install an ohmmeter between the stop lamp switch terminals.
- Check if current passes between terminals when the brake pedal is depressed.

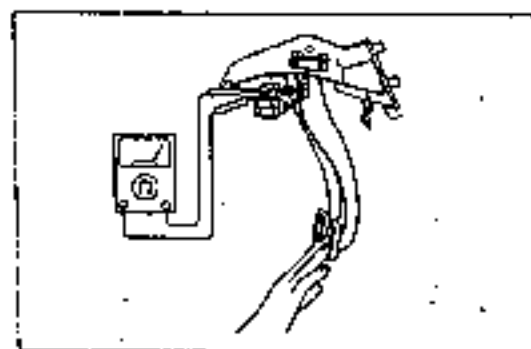

BSX061073

#### FOG LAMP SWITCH

##### Inspection

1. Check if current passes between switch terminals

Status	Terminals			
	a	b	c	d
OFF	○	●	○	
ON		○	○	

○—○ : continuity  
● : illumination (1.4W)

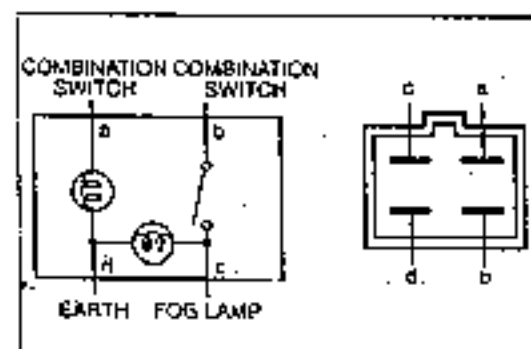

ANR061017

**FLASHER UNIT**

**Note**

- The flasher unit is installed at the right top of the instrument panel.

**Inspection**

- Disconnect the flasher unit.
- Apply 12V to the terminal A and ground terminal C.
- Contact a test light between the terminal B and C of flasher unit.

Test light	Action
Blink	Normal
Non-blink	Replace the flasher unit

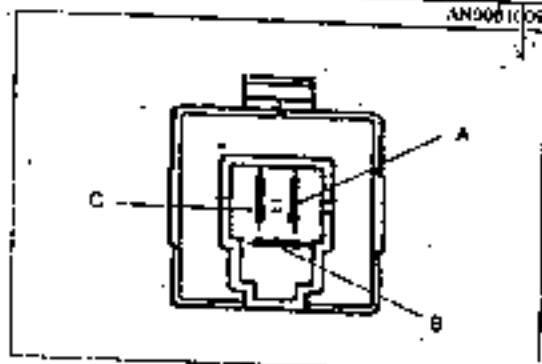
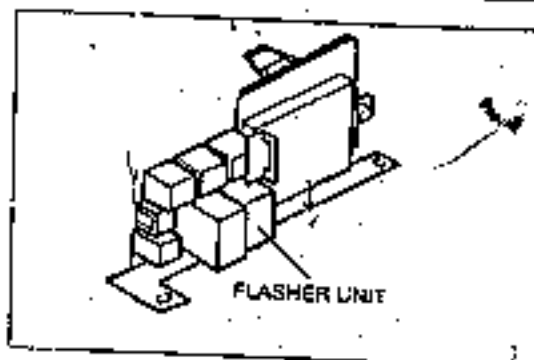

**HAZARD SWITCH**

**Inspection**

**Note**

- The hazard switch is installed at the center of the instrument panel.

**Inspection**

- Disconnect the hazard switch.
- Check for continuity between following terminals of hazard switch.

Position	Terminals							
	B	C	D	F	H	I	J	L
OFF		○				○		
ON			○	○			○	○

○—○ : indicate continuity

- If not as specified, replace hazard switch.

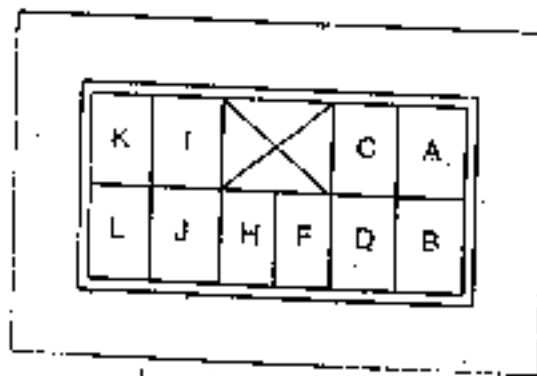

**SWITCH**

**MULTIFUNCTION SWITCH**

**Description and operation**

- The head lamp switch is located at the left of the multifunction switch installed on the steering column and should be replaced as assembly if necessary.
- The low beam head lamp is operated when the rotary switch located at the end of the multifunction switch is rotated by 2 turns counterclockwise.
- The multifunction switch is equipped with 2 functions of high beam and flash-to-pass. The high beam head lamp is turned on when the multifunction switch is pushed to the instrument panel and is turned off when it is pulled to the low beam.
- During the operation of the high beam head lamp, the high beam indicating lamp is illuminated.
- For the flash-to-pass function, the head lamp is operated separately by the rotary switch.
- If the multifunction switch is pulled upwards, the high beam head lamp is illuminated and if the switch is returned, the spring pressure returns the switch to OFF position.

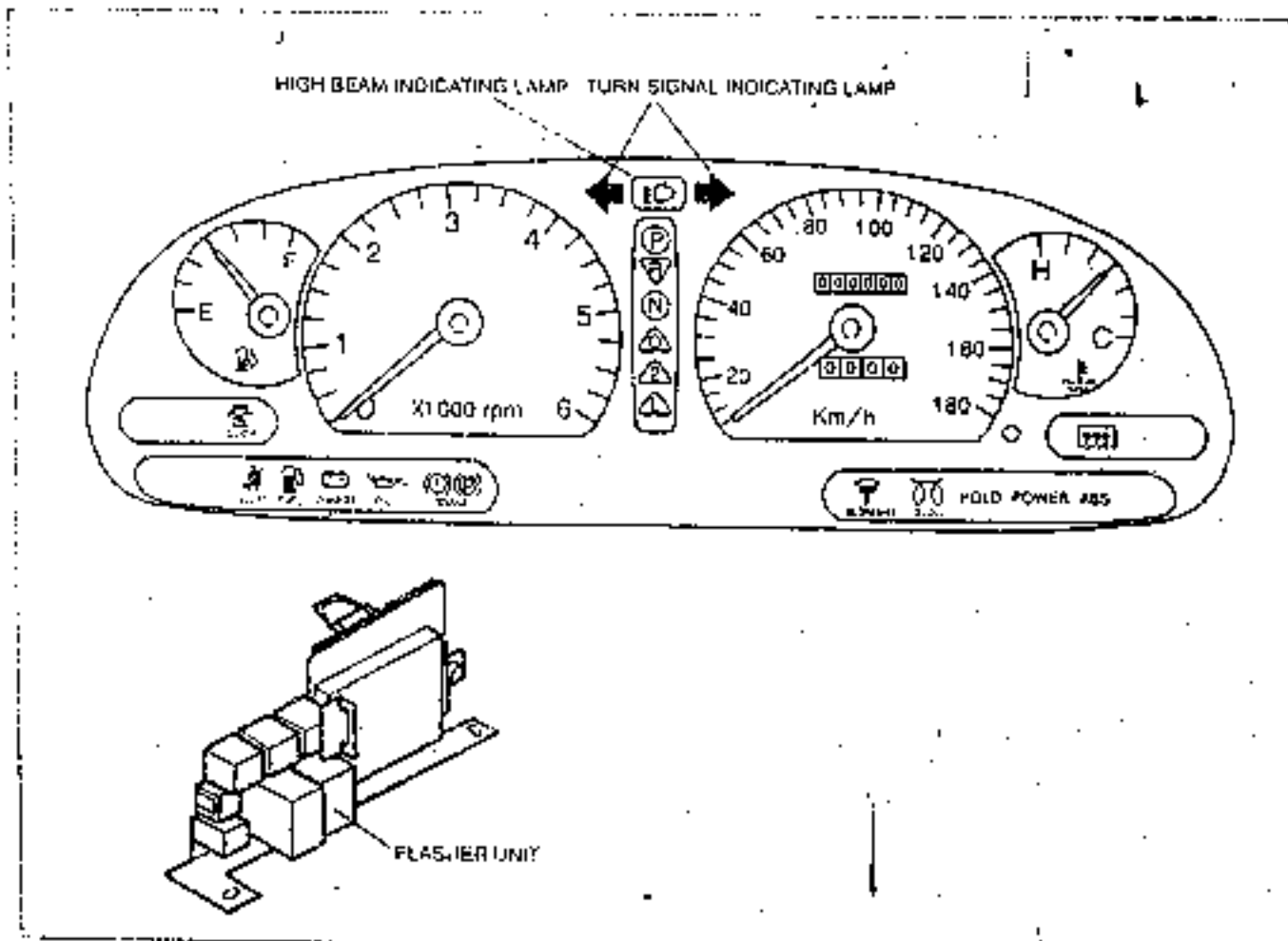

AN6031009/A, N6081018

- The head lamp / turn signal switch, a part of the multifunction switch installed on the steering column and the turn signal is operated by the multifunction switch when the ignition switch is in ON position.
- The turn signal switch and the hazard switch is separated but same switch contact is used for operation.
- The flasher unit is located at the right top of the instrumental panel.



**Inspection**

1. Check if current passes between each terminal by an ohmmeter.

**Light, dimmer and passing switch**

Light	Terminals			BTN	TNS	BA	HU	HL	HB
	Dimmer, passing								
OFF	HU								
	HL								
	HF								
P	HU	○—○	○—○						
	HL	○—○	○—○						
	HF	○—○	○—○						
H	HU	○—○	○—○	○—○	○—○				
	HL	○—○	○—○	○—○	○—○			○—○	○—○
	HF	○—○	○—○	○—○	○—○				

○—○ : continuity

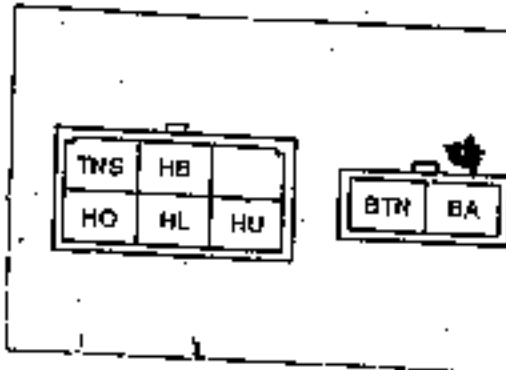

BSX06100

**Turn signal switch**

Position	Terminals		
	IG1	TL	TR
Left	○—○		
N(OFF)			
Right	○—○		○—○

○—○ : continuity

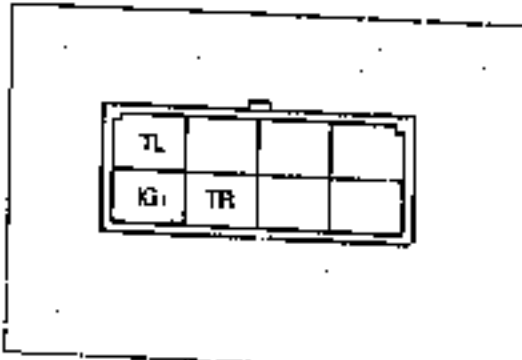

BSX06100

**Wiper & washer switch**

Wiper	Terminals					
	INT	E	AS	SWL	SWH	
OFF	OFF			○—○	○—○	
	I	X	X			
	ON	○—○			○—○	
INT	○—○	○—○	○—○	○—○		
I		X	X			
LO		○—○		○—○		
HI		○—○			○—○	

○—○ : continuity

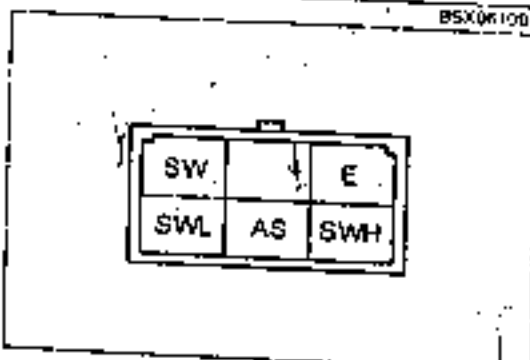

BSX06100

**IGNITION SWITCH**

**Inspection**

- Check for continuity between terminal by an ohmmeter.

Position	Terminals				
	B	ACC	IG1	IG2	ST
ACC	○—○	○—○			
ON	○—○	○—○	○—○	○—○	
ST	○—○		○—○		○—○

○—○ : continuity

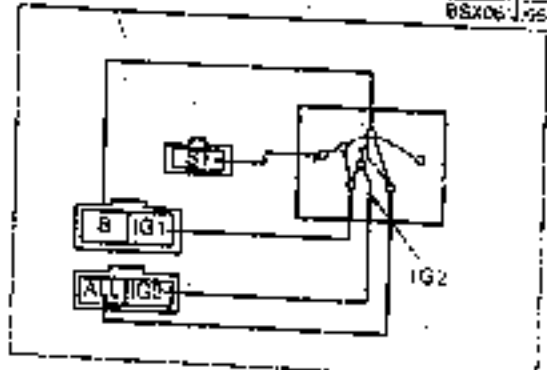

BSX06100

1018 and  
IG  
the  
of

## HORN REMOVAL / INSTALLATION

### Note

- The horn is located at the center of the front bumper.

1. Disconnect the battery negative terminal.
2. Disconnect the horn connector.
3. Remove the horn bracket bolt.
4. Remove the horn.

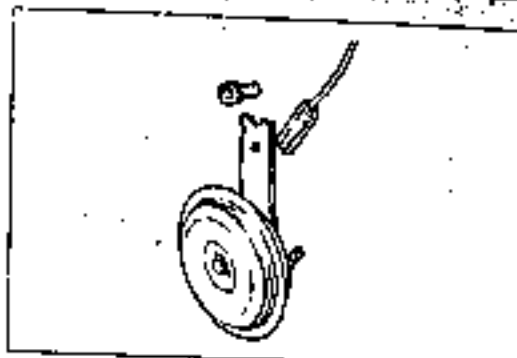

BSX08107B

## INSPECTION

1. Disconnect the horn connector.
2. Check the horn sound by supplying battery 12V to the horn directly.
3. Replace the horn if necessary.

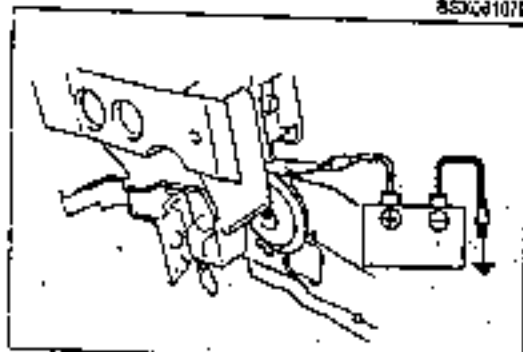

BSX08108B

## HORN RELAY

### Note

- The horn relay is located at the right top of the instrument panel.

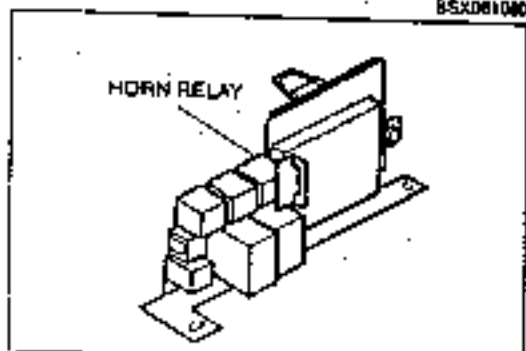

AN9081009

1. Disconnect the battery negative terminal.
2. Remove the relay after disconnecting the horn relay connector.
3. Check if current passes between relay terminals.

Connected to		a	b	c	d
12V	Earth	○	○		
				○	○

○—○ : continuity

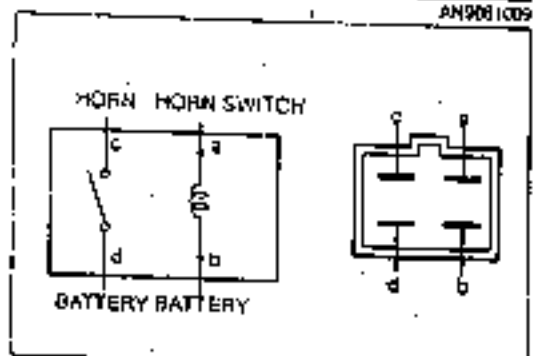

BSX08111A

### REAR WINDOW DEFROSTER DEFROSTER SWITCH

#### Inspection

Check for continuity between terminals by an ohmmeter.

Status	Terminals			
	a	b	c	d
OFF		○	○	
ON		○	○	○

○—○ : continuity  
 • : illumination (1.4W)

### DEFROSTER RELAY

#### Note

- The rear window defroster relay is located at the right top of the instrument panel.

#### Inspection

- Remove the relay after disconnecting the rear window defroster relay.
- Check if current passes between relay terminals.

Connected to		a	b	c	d
12V	Earth				
		○	○		
a	b			○	○

○—○ : continuity

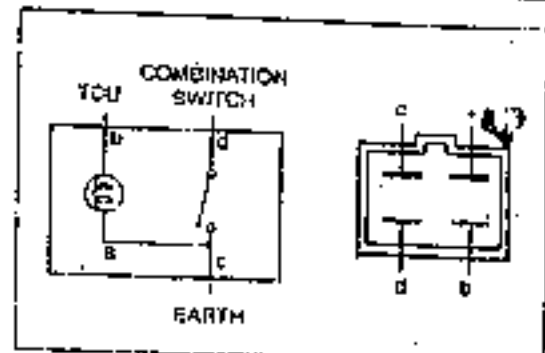

AN9081017

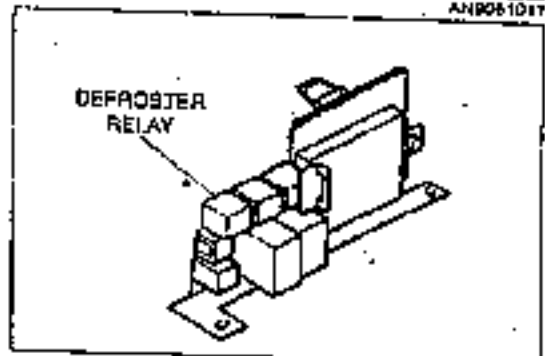

AN9081009

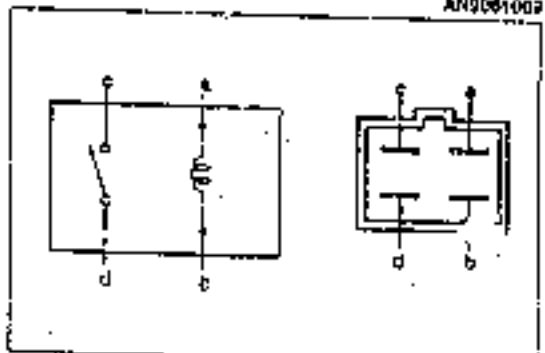

BSX061814

**TIMER CONTROL UNIT(TCU)**

**DESCRIPTION**

**"Key In Ignition" warning chime**

If the key is not removed after turning off the ignition switch and opening the door when the keyless switch is closed, the warning sound is generated.

**"Lights On" warning chime**

If the ignition switch is turned off and the door is opened when the combination switch is closed, the warning sound is generated.

**Key illumination timer**

If the door is opened when the keyless switch is open, the timer starts operating and the key illumination is operated for 20-40 seconds. If the keyless switch is turned on, it stops operating immediately.

**Time lag power window timer**

If the ignition switch is turned off, the timer starts operating to supply the power to the power window motors for about 90 seconds.

**Rear window defroster control timer**

If the defroster switch is turned on when the key switch is closed, the defroster control timer starts operating and stops operating after about 12-18 minutes. If the key switch or defroster switch is turned off during the defroster control timer operation, the defroster control timer stops operating.

REMOVAL

Note

- The timer control unit is located at the right top of the instrument panel.

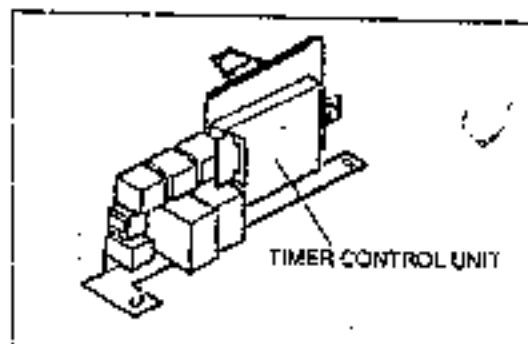

AN0001003

INSPECTION

Measure the voltage on terminals of the timer control unit.

Terminal	Input	Output	Connected to	Measuring condition	Results (V)
A		○	Power window relay	Power window operating	below 1.2
				Power window not operating	12
B		○	Key hole illumination	ON	below 1.2
				OFF	12
C		○	Defroster relay	Defroster switch ON	below 1.2
				Defroster switch OFF	12
D	○		Defroster switch	Defroster switch ON	0
				Defroster switch OFF	12
E		○	Master set (seat belt warning lamp)	ON (fastened)	0
				OFF (not fastened)	12
F	○		Power door lock main switch (lock)	Locked	0
				Unlocked	12
G	○		Key switch	IG key ON	12
				IG key OFF	0
H	○		Power door lock main switch (unlock)	Locked	12
				Unlocked	0
I	○		Power door lock link switch (unlock)	Locked	12
				Unlocked	0
J	○		Power door lock link switch (lock)	Locked	0
				Unlocked	12
K					
L					
M		○	Horn relay	ON	1.2
				OFF	12
N	○		Combination switch	ON	12
				OFF	0
O					
P	○		Key reminder switch	IG key ON	12
				IG key is removed from IG switch	0
Q			Earth		0
R			Battery (for door lock only)	Always	12

61-14 BODY ELECTRICAL SYSTEM TIMER CONTROL UNIT(TCU)

Terminal	Input	Output	Connected to	Measuring condition	Results (V)
S		O	Power door lock motor (lock)	Locked	12
				Others	0
Y	O		Door switch	ON (door open)	0
				OFF (door closed)	12
U		O	Power door lock motor (unlock)	Unlocked	12
				Others	0
V	--	--	Battery	Always	12

**INSTRUMENT PANEL(METERS)**

**DESCRIPTION AND OPERATION**

The meter consists of speedometer, tachometer and odometer.  
 Fuel and coolant temperature gauges are installed and warning and indicating lamps consist of turn signal lamps and warning lamp.  
 The meter is divided into 2 parts and consists of meter and 3 connectors connected to the rear.

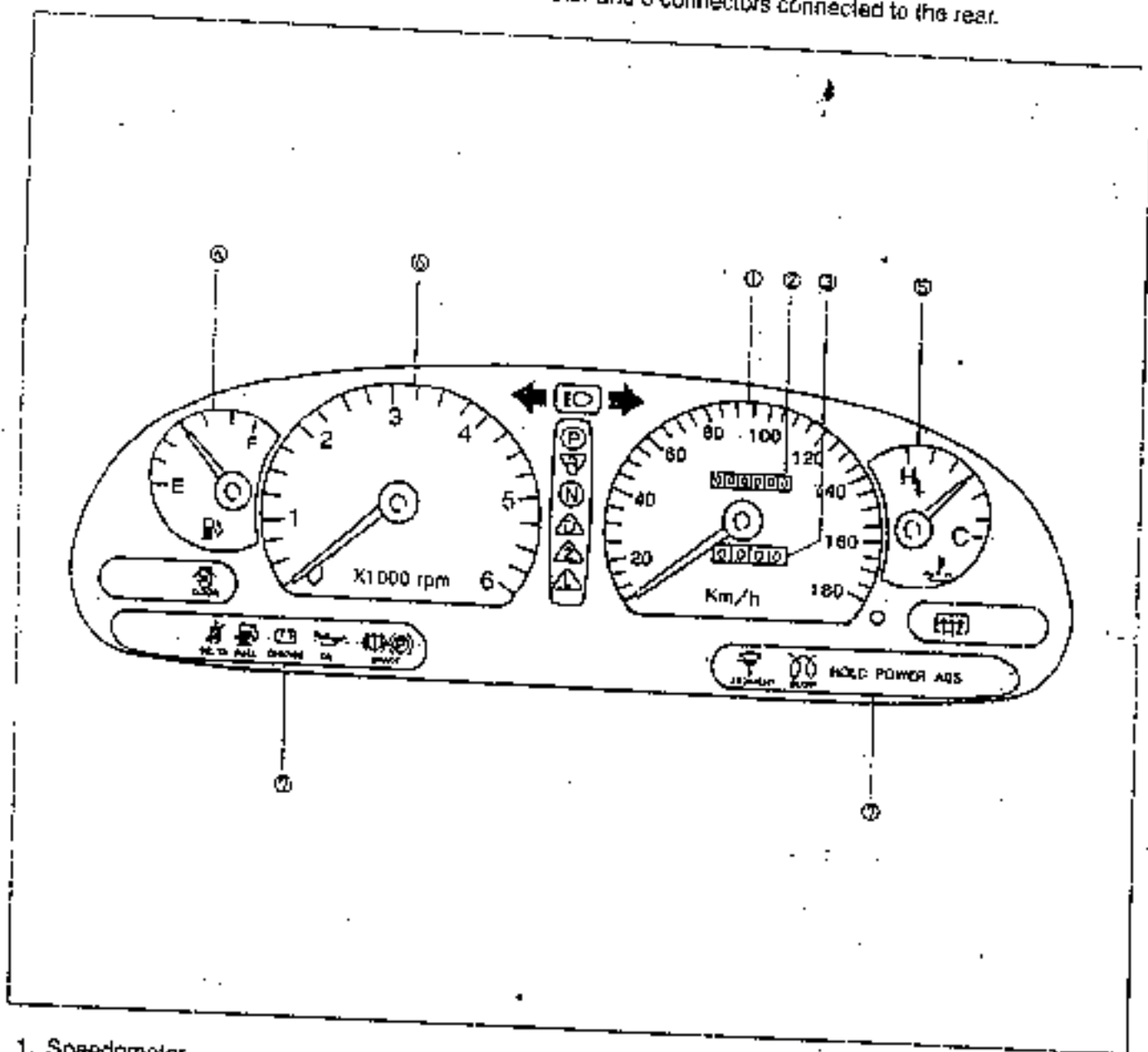

- 1. Speedometer
- 2. Odometer
- 3. Tripmeter
- 4. Fuel gauge

- 5. Coolant temperature gauge
- 6. Tachometer
- 7. Warning and indicating lamp

**Speedometer and odometer**

- The cableless type speedometer is adopted.
- For the cableless type speedometer, current is supplied to the cross coil according to the pulse signal from the speed sensor mounted on the transmission to indicate the reading.
- The amount of current through the cross coil is determined by the indicator angle calculated by the calculating element based on the number of pulses counted for the specified time.
- The current is supplied to one cross coil according to the result calculated by the calculating element. Magnetic field is generated and the indicator indicates the speed by this current through the cross coil.

The speed sensor is driven by the output shaft of the transmission. The magnet in the speed sensor attached on the driven gear changes the magnetic field at the coil. The coil generates current by the change of magnetic field. AC signal of 4 pulses per 1 rotation of the speed sensor is sent to the meter.

**Fuel gauge**

The fuel gauge is the coil type of which indicator reading is moved by the amount of current passing through the cross coil from the variable resistance sensor in the fuel tank. If the fuel tank is full of fuel, the resistance of the fuel gauge decreases to increase the current that the fuel gauge indicates "F". To the contrary, if the fuel tank is empty, current decreases that the fuel gauge indicates "E".

The current through the resistor is determined by the variable resistor of the fuel gauge. The variable resistor is adjusted by the fuel amount in the fuel tank. The float attached to the fuel gauge floats on the surface of fuel to inform the fuel gauge of the fuel amount. If the fuel amount changes, the level of float also changes so that the amount of current passing through the circuit is changed. The higher the level of the float is, the less the resistance of the circuit becomes.

The amount of the current passing through the coil is determined by the resistance of the fuel gauge unit. The resistance of the fuel gauge unit is changed according to the amount of fuel in the fuel tank. The float attached to the fuel gauge floats on the surface of fuel and follows the fuel level when the amount of fuel changes. As the resistance differs at each position, the amount of current passing through the circuit is changed. The higher the level of the float is, the less the resistance of the circuit becomes.

**Coolant temperature gauge**

The engine coolant temperature gauge is located at the right of the meter. The gauge is of coil type and the reading is indicated according to the amount of current. The resistance of the coolant temperature sensor mounted on the engine changes according to temperature to change the amount of current. Consequently, the gauge indicates the result. If the coolant temperature is low, the resistance of the sensor increases and the amount of current passing through the circuit is also reduced.

If the coolant temperature is high, the resistance of the temperature sensor decreases to increase current and the reading indicates "H" area. To the contrary, if the coolant temperature is low, the resistance of the temperature sensor increases to decrease current and the reading indicates "C" area.

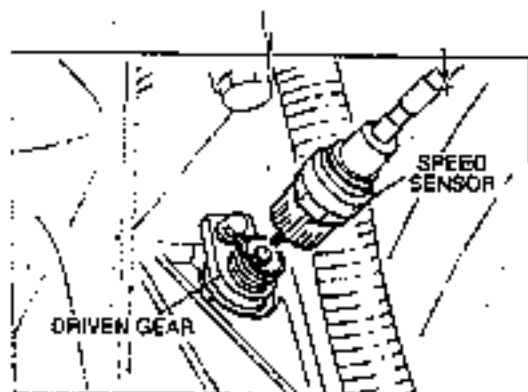

BSX061117

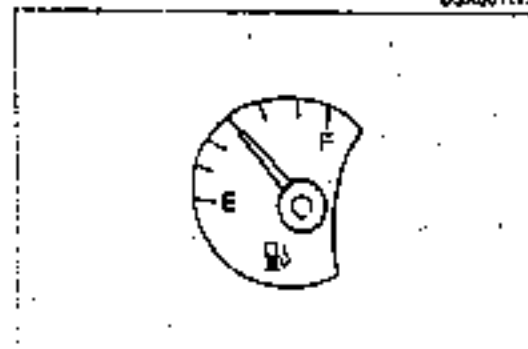

AN8051023

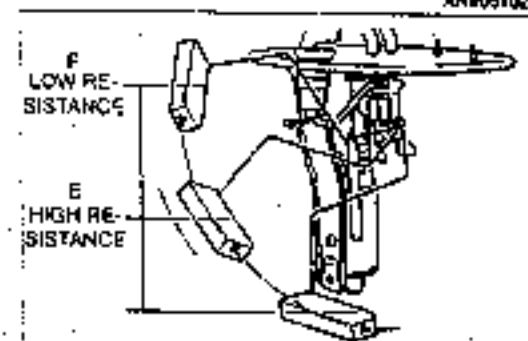

BSX061119

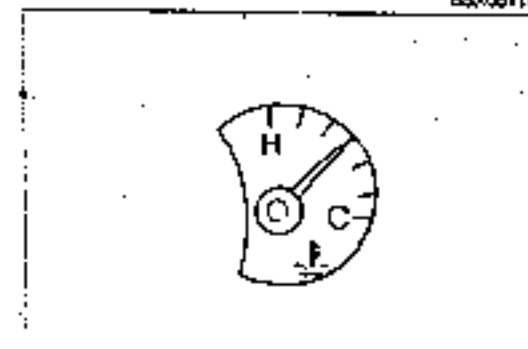

AN8061024



Problem	Possible Cause	Action
The speedo meter does not operate or operates wrong.	<ul style="list-style-type: none"> <li>• Speedometer malfunction</li> <li>• Speed sensor malfunction</li> <li>• Driven gear malfunction</li> <li>• Circuit broken</li> </ul>	Replace Replace Replace Repair
The tachometer does not operate.	<ul style="list-style-type: none"> <li>• Tachometer</li> <li>• Circuit broken</li> </ul>	Replace Repair
The coolant temperature gauge does not operate.	<ul style="list-style-type: none"> <li>• Circuit broken</li> <li>• Coolant temperature gauge malfunction</li> <li>• Coolant temperature sensor malfunction</li> </ul>	Repair Replace Replace
The fuel gauge does not operate.	<ul style="list-style-type: none"> <li>• Circuit broken</li> <li>• Fuel gauge unit malfunction</li> <li>• Fuel gauge malfunction</li> </ul>	Repair Replace Replace

**THE SPEEDOMETER DOES NOT OPERATE OR OPERATES WRONG.**

**Step 1**

1. Check if the meter set and the speed sensor connector are connected correctly.
2. If normal, check for step 2 items.

**Step 2 : speed sensor check**

1. Disconnect the speed sensor connector mounted on the speedo driven gear of the transmission.
2. Remove the speedo sensor.
3. After connecting battery positive terminal to the No. 1 terminal of the speed sensor, connect battery negative terminal to the No. 2 terminal of the sensor.
4. Connect negative and positive terminals of the tester to No. 2 and No. 3 terminal of the speed sensor, respectively.
5. Rotate the speed sensor shaft.
6. Check if voltage change from 0V to 12V between the No. 3 and No. 2 terminals.

**Note**

- If voltage does not change 4 times per 1 rotation of the speed sensor shaft, replace the speed sensor.

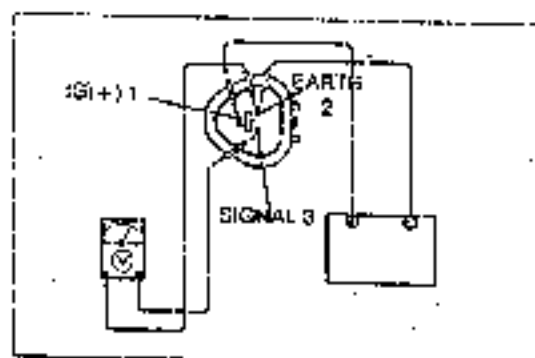

BSX061123

**Step 3 : speedometer check**

1. Remove the meter set.
2. Check if current passes between "BK(B)" and "CH(R/L)" terminals of the speedometer. If voltage does not change 4 times per 1 rotation of the speedo sensor, replace the speedo meter.

**The tachometer does not operate.**

1. Remove the instrument cluster (meter).
2. Connect the test tachometer to "AL"(LG/R) and "BK"(B) tachometer terminals of the instrument wire harness.
3. Start the engine.
4. Check if the test tachometer indicates the engine speed.

Indicated engine speed	Action
Normal	Replace the tachometer
Abnormal	Repair the wire harness (between instrument cluster and tach sensor)

**The coolant temperature gauge does not operate.**

1. Disconnect the connector of the coolant temperature switch.
2. Connect the SST red cord to the connector and ground the black cord.
3. Adjust the resistance of the SST to the value in the figure.
4. Turn on the ignition switch and check if the indicator indicates the correct value.

Gauge Status	Action
Normal	Replace the coolant temperature sensor.
Abnormal	Refer to the step. 7

**Caution**

- Perform the above items for more than 2 minutes to understand the condition correctly.
- The allowable indicating error is twice of the indicator width.

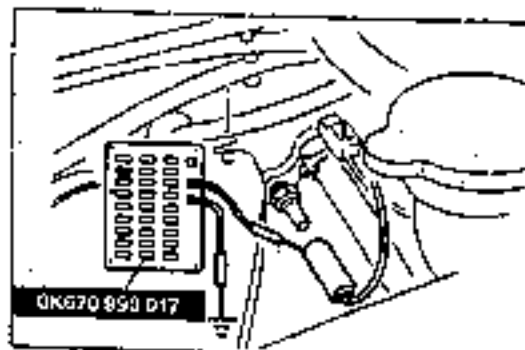

B8X081126

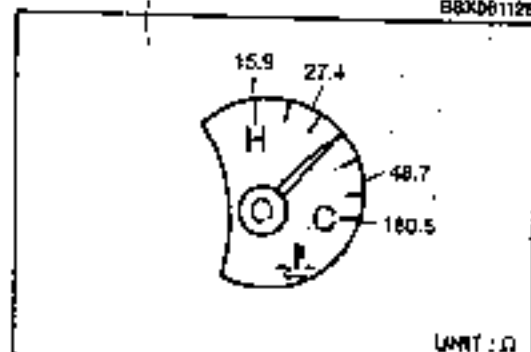

ANR081024

5. Remove the instrument cluster (meter set).
6. Supply 12V voltage to the "CF" terminal and ground the "BK" terminal.
7. Connect the SST red and black cords to "CN" terminal and battery negative terminal respectively.

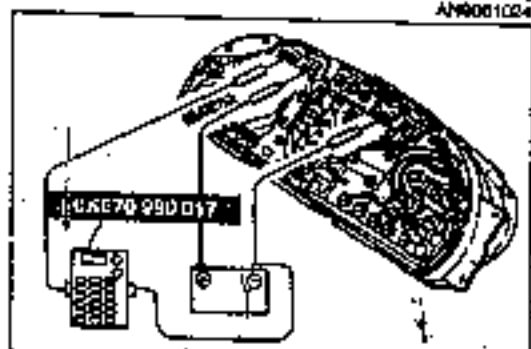

ANR081024

8. Adjust the resistance of the SST to the value in the figure.
9. Check if the indicator indicates the correct resistance value.

**Caution**

- Perform the above items for more than 2 minutes to understand the condition correctly.
- The allowable indicating error is twice of the indicator width.

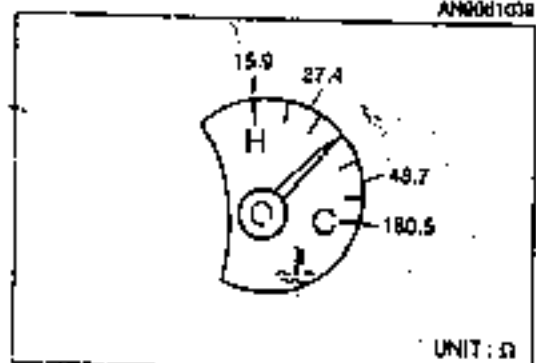

ANR081024

The fuel gauge does not operate.

1. Disconnect the connector from the fuel gauge sender unit.
2. Connect the SST red cord to the "LG/Y" terminal and ground the black cord.

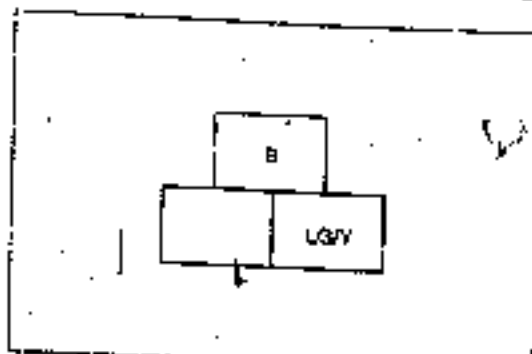

AN9081027

3. Adjust the resistance of the SST to the value in the figure.
4. Turn on the ignition switch and check if the indicator indicates the correct value.

Gauge status	Action
Normal	Replace the coolant temperature sensor.
Abnormal	Refer to the step. 7.

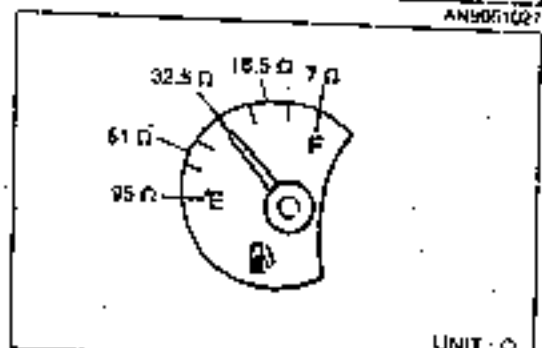

UNIT : Ω

AN9081027

**Caution**

- Perform the above items for more than 2 minutes to understand the condition correctly.
- The allowable indicating error is twice of the indicator width.

5. Remove the instrument cluster.
6. Supply 12V voltage to the "CF" terminal and ground the "BK" terminal.
7. Connect the SST red and black cords to "AC" terminal and battery negative terminal respectively.

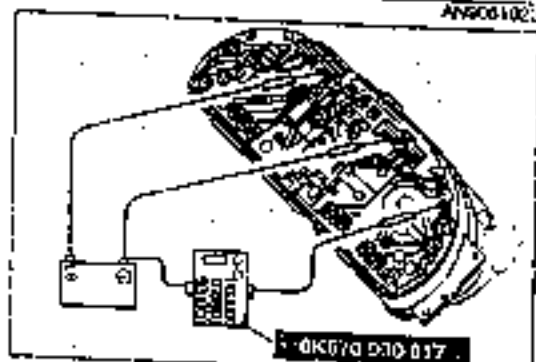

AN9081010

8. Adjust the resistance of the SST to the value in the figure.
9. Check if the indicator indicates the correct resistance value.

Indicated engine speed	Action
Normal	Repair the wire harness. (between instrument cluster and fuel gauge sender unit)
Abnormal	Replace the fuel gauge.

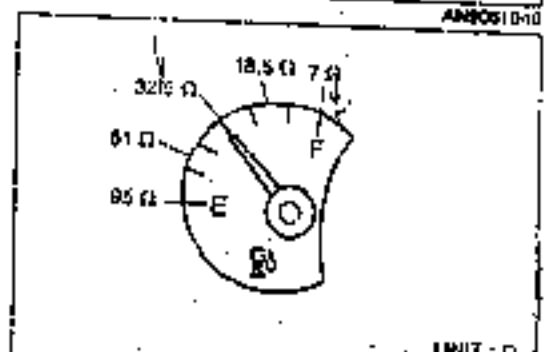

UNIT : Ω

AN9081027

**Caution**

- Perform the above items for more than 2 minutes to understand the condition correctly.
- The allowable indicating error is twice of the indicator width.

**FUEL GAUGE SENDER UNIT****Inspection**

1. Disassemble the fuel tank gauge unit.
2. Disconnect the fuel gauge sender unit connector.
3. Check the resistance by moving the unit arm from F to E position slowly.
4. If abnormal, replace the fuel sender unit.

**Resistance**

Position	Resistance ( $\Omega$ )	Position	Resistance ( $\Omega$ )
E	$110 \pm 7$	3/4	$16.5 \pm 3$
1/4	$51 \pm 5.5$	F	$3 \pm 2$
2/4	$32.5 \pm 4$	—	—

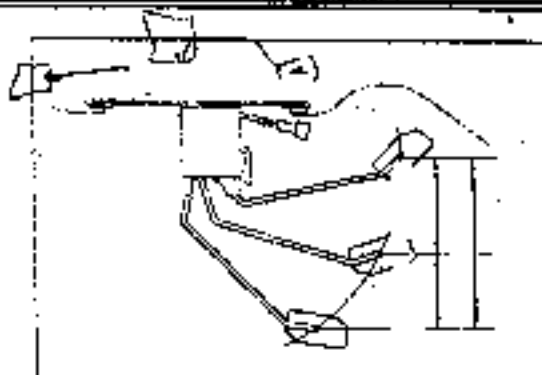

B5X061137

**COOLANT TEMPERATURE SENSOR****Inspection**

1. Remove the sensor.
2. Position the sensor as shown in the figure.
3. Measure the resistance heating the water gradually.
4. If the resistance is out of the standard, replace it.

Standard : 190-260 (at 50°C (92°F))

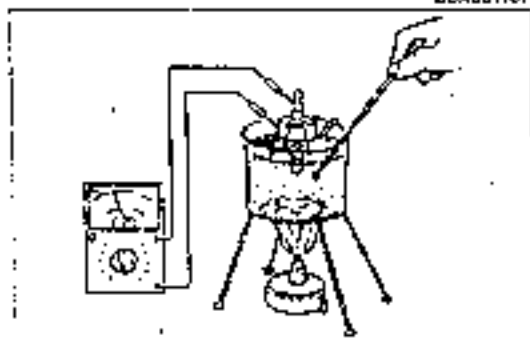

B5X061139

## WARNING LAMP

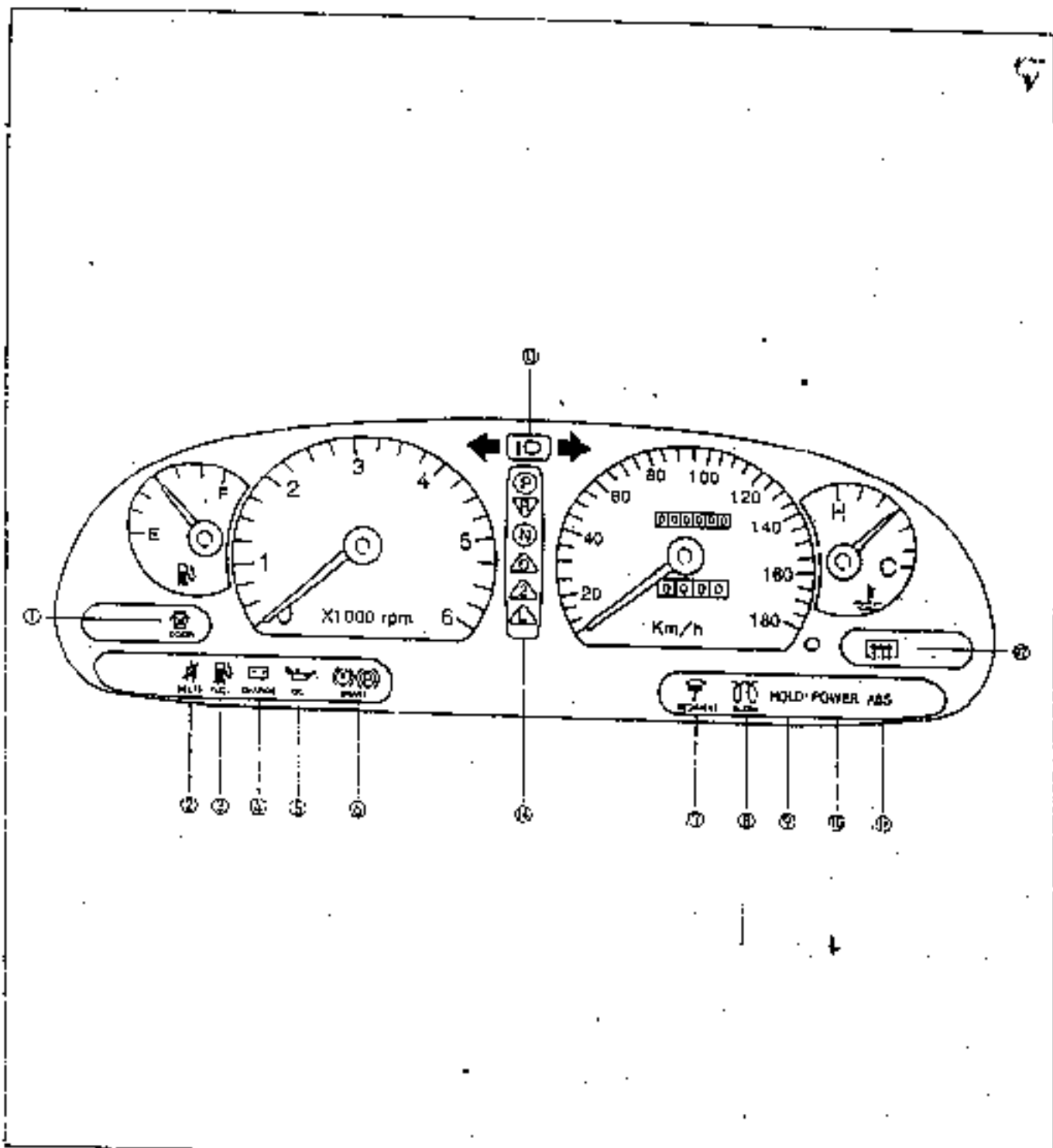

1. Door ajar warning lamp
2. Seat belt warning lamp
3. Low fuel level warning
4. Alternator warning lamp
5. Engine oil pressure warning lamp
6. Brake fluid level and brake system lamp
7. Sedimentor warning lamp

8. Glow plug indicator light
9. Hold mode indicator (ATX vehicle)
10. Power mode indicator (ATX vehicle)
11. ABS warning lamp (ABS vehicle)
12. Rear window defroster indicator
13. High beam indicator
14. Auto transmission range indicator

**Brake system warning lamp**

1. Disconnect the brake fluid switch connector.
2. Connect a jumper wire between Y/B and B terminals.
3. Start the engine and check if the brake warning lamp is illuminated.

**Note**

- Before checking, release the parking brake.

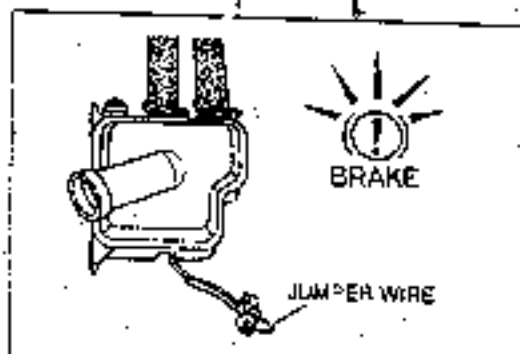

AN9081028

4. If not illuminated, check fuse, bulb and wiring and replace as necessary.

**Brake fluid switch**

Connect an ohmmeter to the connector terminal of the brake fluid switch. Check the current passing condition according to amount of the brake fluid. The current should pass when the level is below the "MIN" mark and should not pass when the level is above the "MAX" mark. If abnormal, replace the switch.

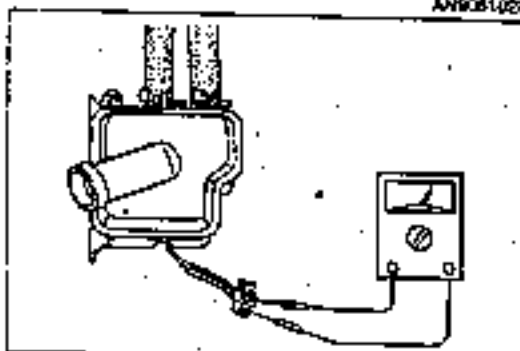

AN9081029

**Low fuel level warning lamp**

1. Disconnect the connector from the fuel tank unit.
2. Ground the Y terminal.
3. Start the engine and check the low fuel level warning lamp is illuminated.
4. If not illuminated, check fuse, bulb and wiring and replace as necessary.

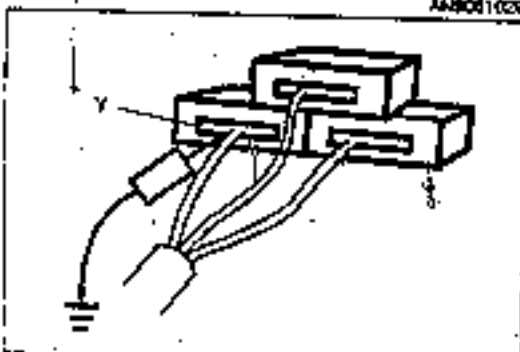

AN9081030

**Alternator warning lamp**

1. Start the engine and ground the "GR/B" wire to the body.
2. Check if the charging warning lamp is illuminated.
3. If not illuminated, check the warning lamp and alternator and repair or replace them.

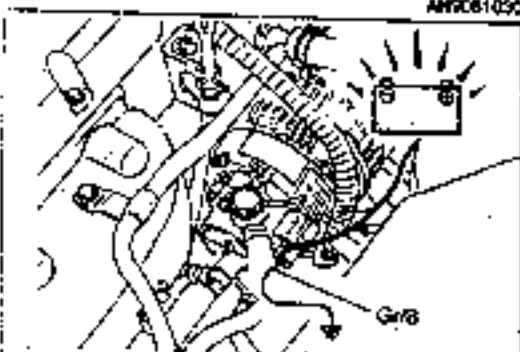

AN9081031

**Engine oil pressure warning lamp**

1. Disconnect the oil pressure switch connector.
2. Start the engine and ground the Y/A wire to the body.
3. Check if the oil pressure warning lamp is illuminated. If not illuminated, check the bulb or oil pressure switch and replace it or repair the wiring.

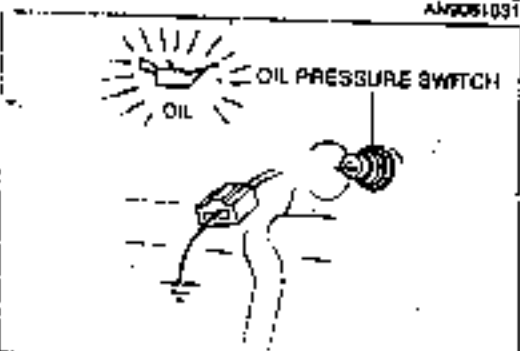

AN9081032

### Seat belt warning lamp

1. Disconnect the connector from the seat belt buckle switch.
2. Connect a jumper wire between "B/R" and B terminals.
3. Turn on the engine switch and check if warning lamp and chime operate for about 6 seconds.
4. If abnormal, check fuse, buckle switch, wire harness and time control unit. If necessary, replace or repair them.

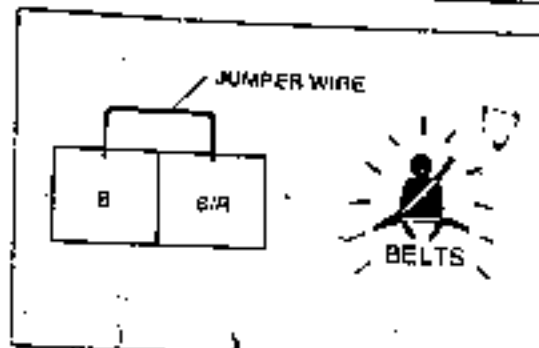

AN9061033

### Seat belt switch

Seat belt status	Continuity
Engaged	No
Released	Yes

### Sediment warning lamp

1. Disconnect the connector from the sedimenter sensor.
2. Connect a jumper wire between "Y/G" and "B" terminals.
3. Turn on the engine switch and check if warning lamp is illuminated.
4. If abnormal, check fuse and wire harness.

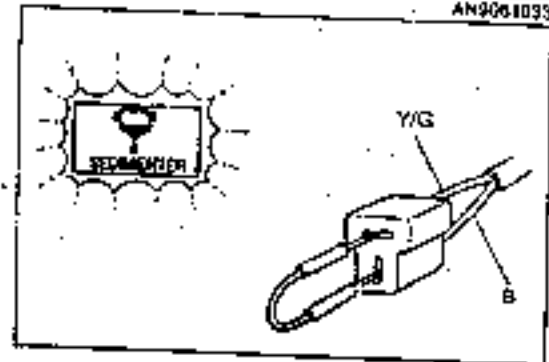

AN9061034

### SPEAKER

#### Inspection

1. Measure the resistance by an ohmmeter.

#### Note

- Set the ohmmeter to x 1  $\Omega$  range.

#### Resistance

Front speaker : about 4  $\Omega$

Rear speaker : about 8  $\Omega$

Back door speaker : about 8  $\Omega$

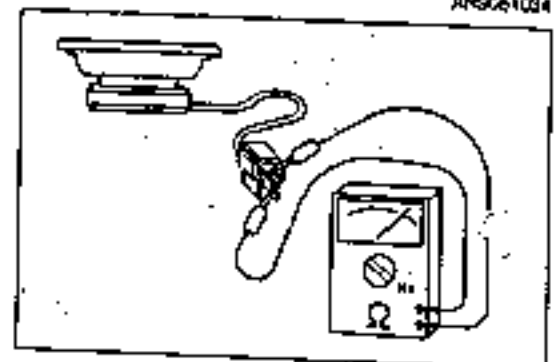

AN9001088

## KEYLESS ENTRY SYSTEM

## SYSTEM FLOW

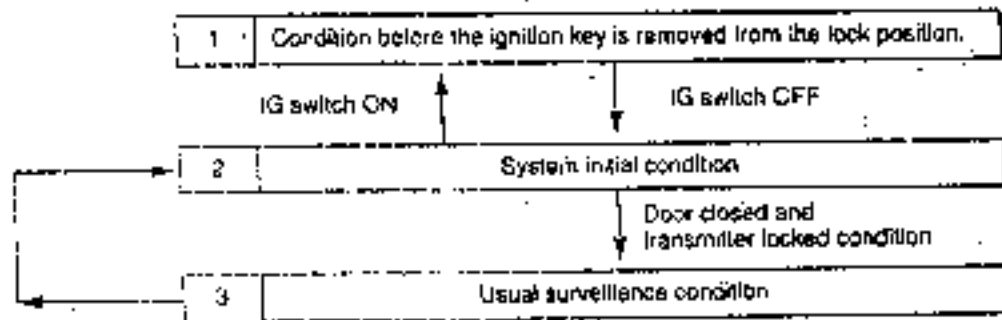

## Note

- Surveillance condition  
If the lock switch on the transmitter is pressed when the IG key is not inserted and the door is closed, the door is locked and the horn operates and then it enters surveillance condition.
- Cancel of surveillance condition  
cancel 1 : transmitter unlock switch ON  
The driver / passenger side door is unlocked by a normal key. (key cylinder switch ON)  
cancel 2 : keyless switch ON (IG switch ACC)

## OPERATING CONDITION

System status	Timer time	Keyless switch	IG switch	Door switch	Door key	Output		Note
						Horn / hazard	service stop	
1	—	key is turned ON	—	—	—	OFF	OFF	can not be remote controlled
2	—	OFF	OFF	—	—	OFF	OFF	
3	—	OFF	OFF	OFF	OFF	OFF	OFF	horn operation (1B ms)



**PASSWORD ENTERING METHOD**

1. Turn the ignition switch to ACC position. (keyless switch ON)
2. Set the operation mode of the transmitter main body to [memory 1].
3. After entering the password, send it by the transmitter.

4. Set the operation mode of the receiver to [operation].
5. Remove the ignition switch and press lock/unlock switch on the transmitter to check if the system operates.

**INSPECTION**

Receiver

Terminal	Wire Color	Measuring condition	Voltage	Note
a(power supply)	R/L	Always	12V	
b(earth)	B	Always	0V	
c(keyless switch)	G/B	Keyless switch ON	12V	0V for OFF
d(ignition switch)	L/Y	Ignition switch in ACC	12V	
e(lock)	Y	Lock switch ON	0V	
f(unlock)	Y/L	Unlock switch ON	(for 150ms)	
g(sel)	W/B	Operator mode in memory position	5V	

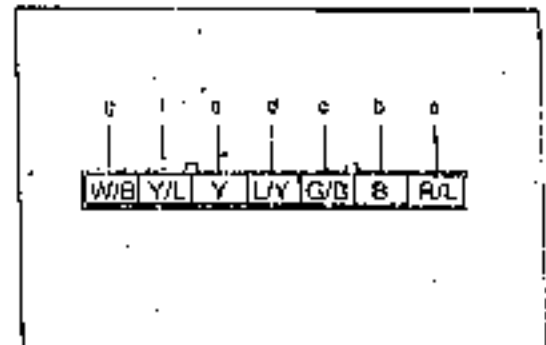

AGX051029

# AIR CONDITIONER

62

INSPECTION .....	62-22
OUTLINE .....	62- 3
REFRIGERANT SYSTEM .....	62- 9
REMOVAL/INSTALLATION .....	62-14
SPECIFICATIONS .....	62-25
TROUBLESHOOTING GUIDE .....	62-19
WIRING DIAGRAM .....	62- 8

OUTLINE

STRUCTURAL VIEW

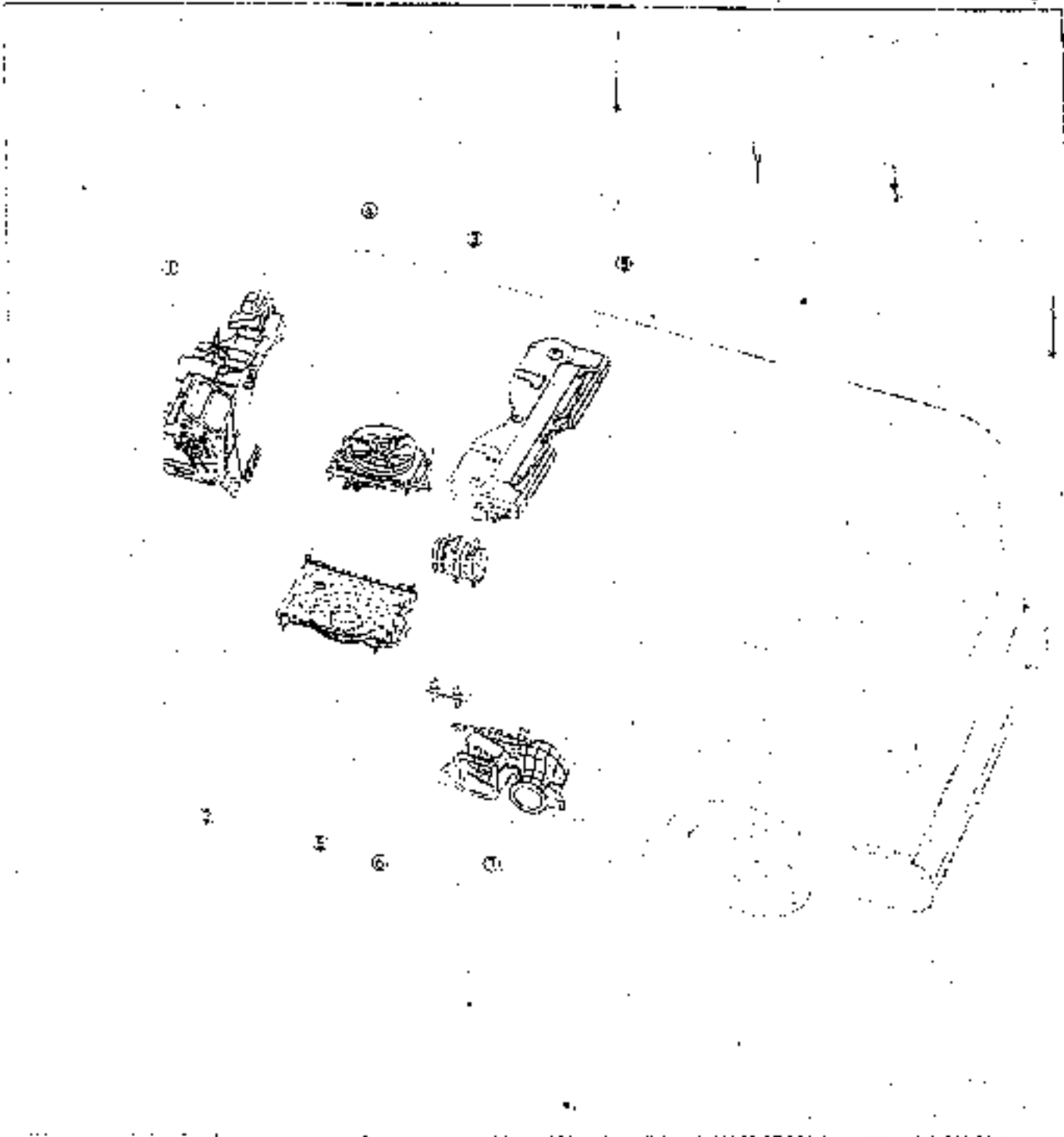

- 1. HVAC unit
- 2. Main condenser
- 3. Sub condenser
- 4. Front control

- 5. Compressor
- 6. Rear control
- 7. Rear heater
- 8. Evaporator

AIR FLOW

Vent mode

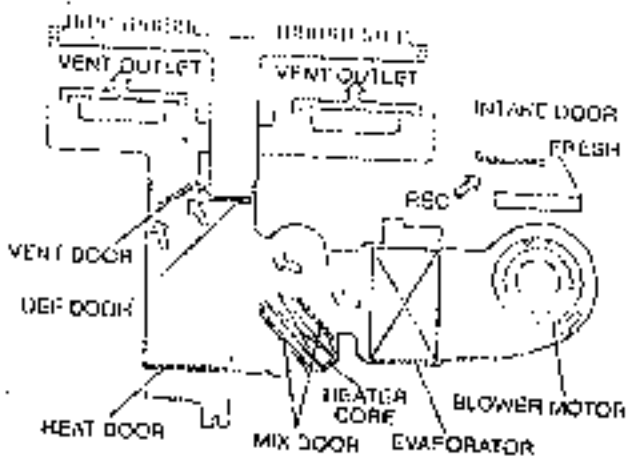

61-level mode

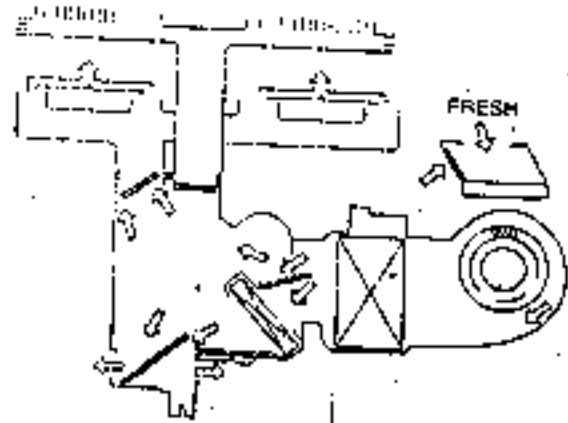

Heat mode

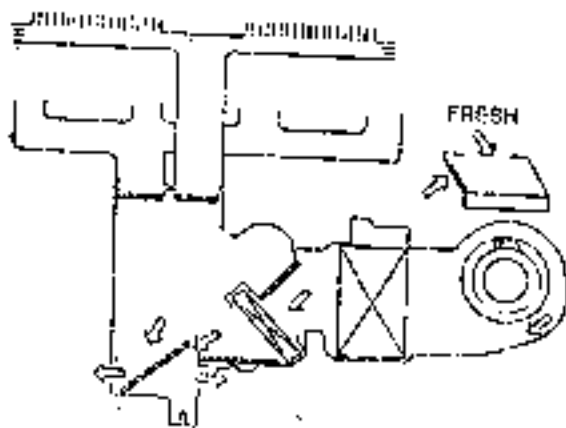

Def/Heat mode

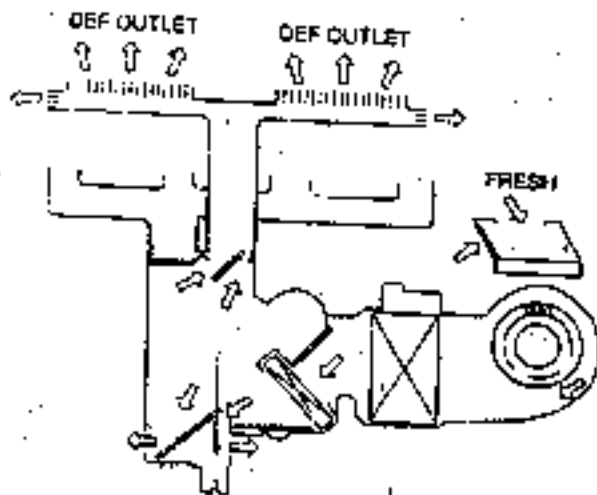

Def

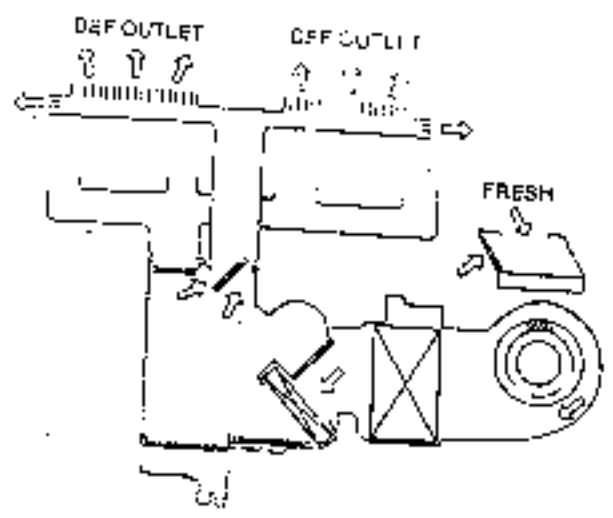

Heater(Rear)

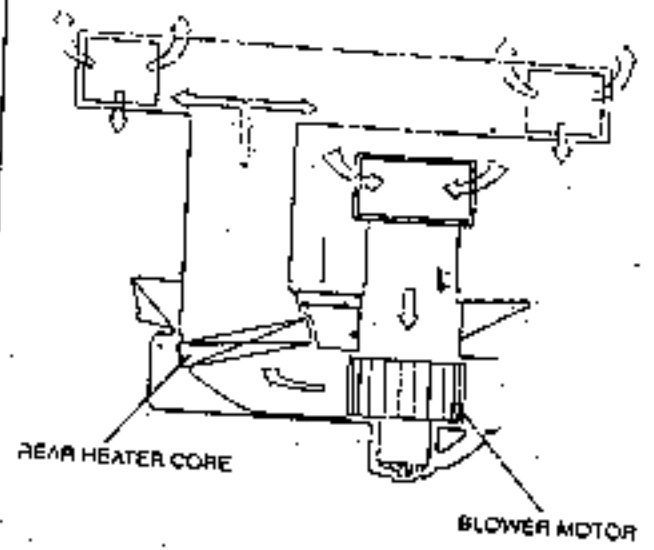

Rear cooler

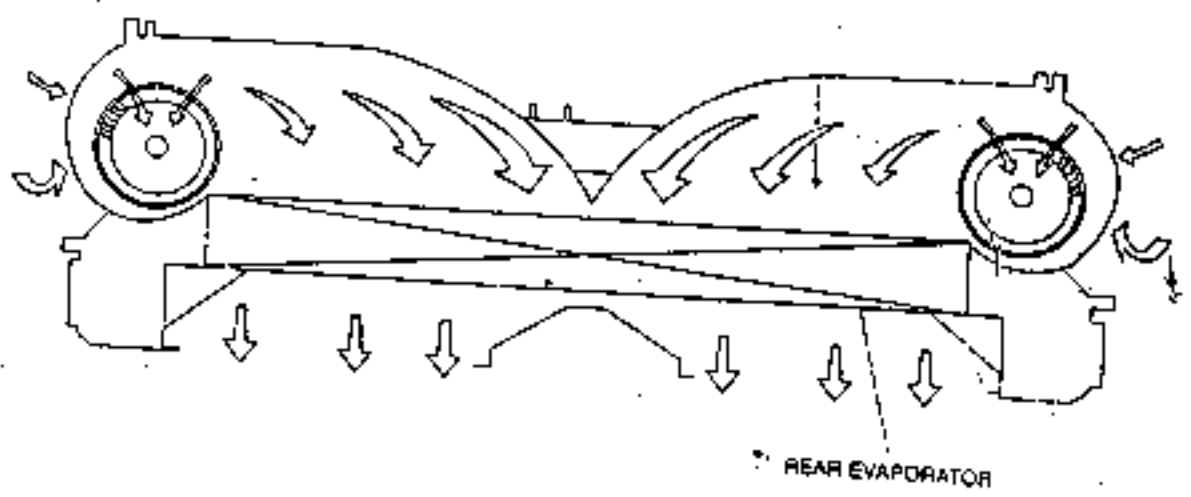

WIRING DIAGRAM

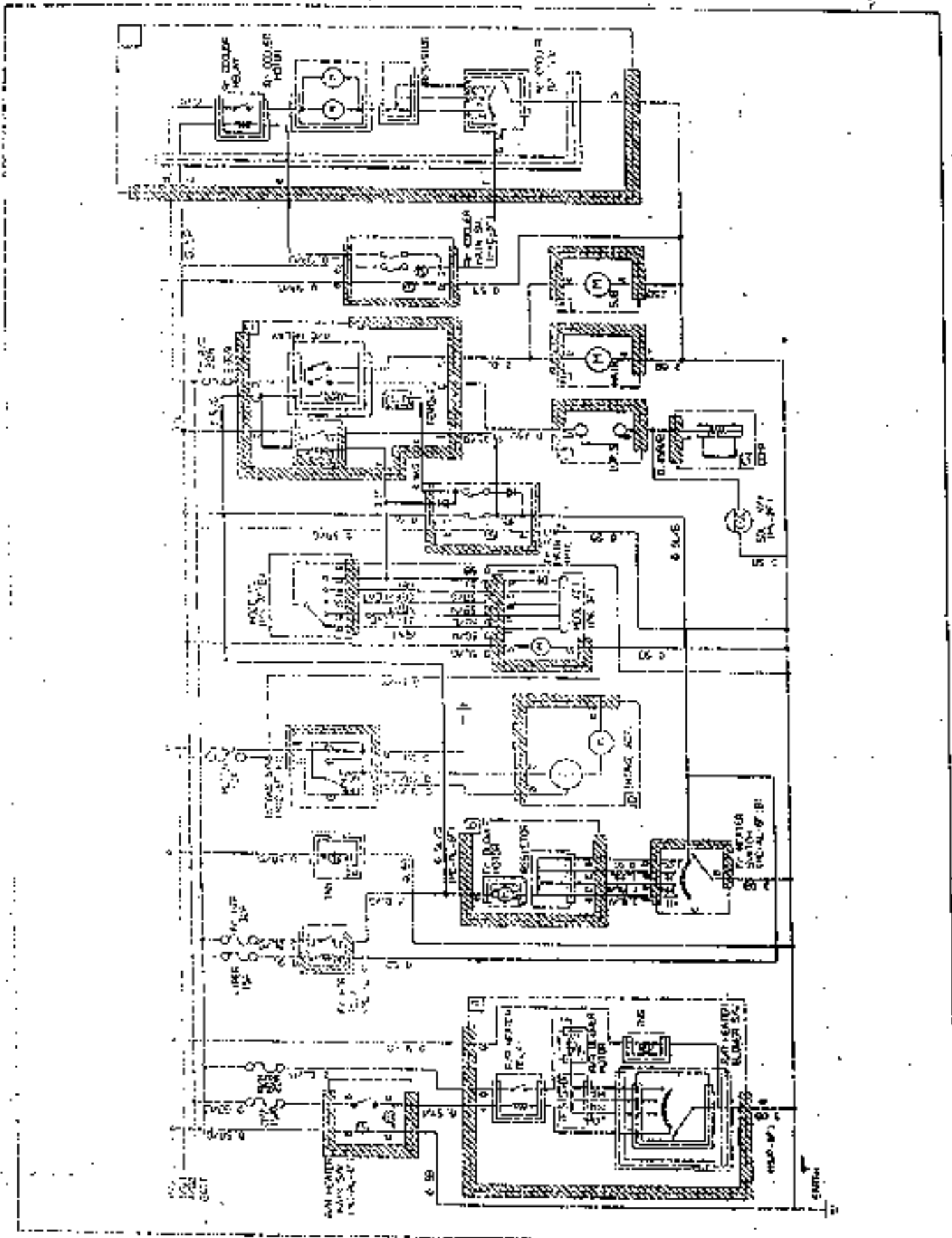

## REFRIGERANT SYSTEM

## REPAIR/REPLACE

## Working Procedures

In order to return the compressor oil in the refrigerant line to the compressor, repair or replace the refrigerant system after operating the oil return.

## Operating Condition

1. Operate the engine at about 2,000 rpm.
2. Turn the A/C switch on after turning the blower switch to maximum speed.
3. Operate for about 20 minutes after turning the temperature control lever to the maximum cooling position.

## Note

- The reading of manifold gauge indicator might be changed by the ambient temperature.

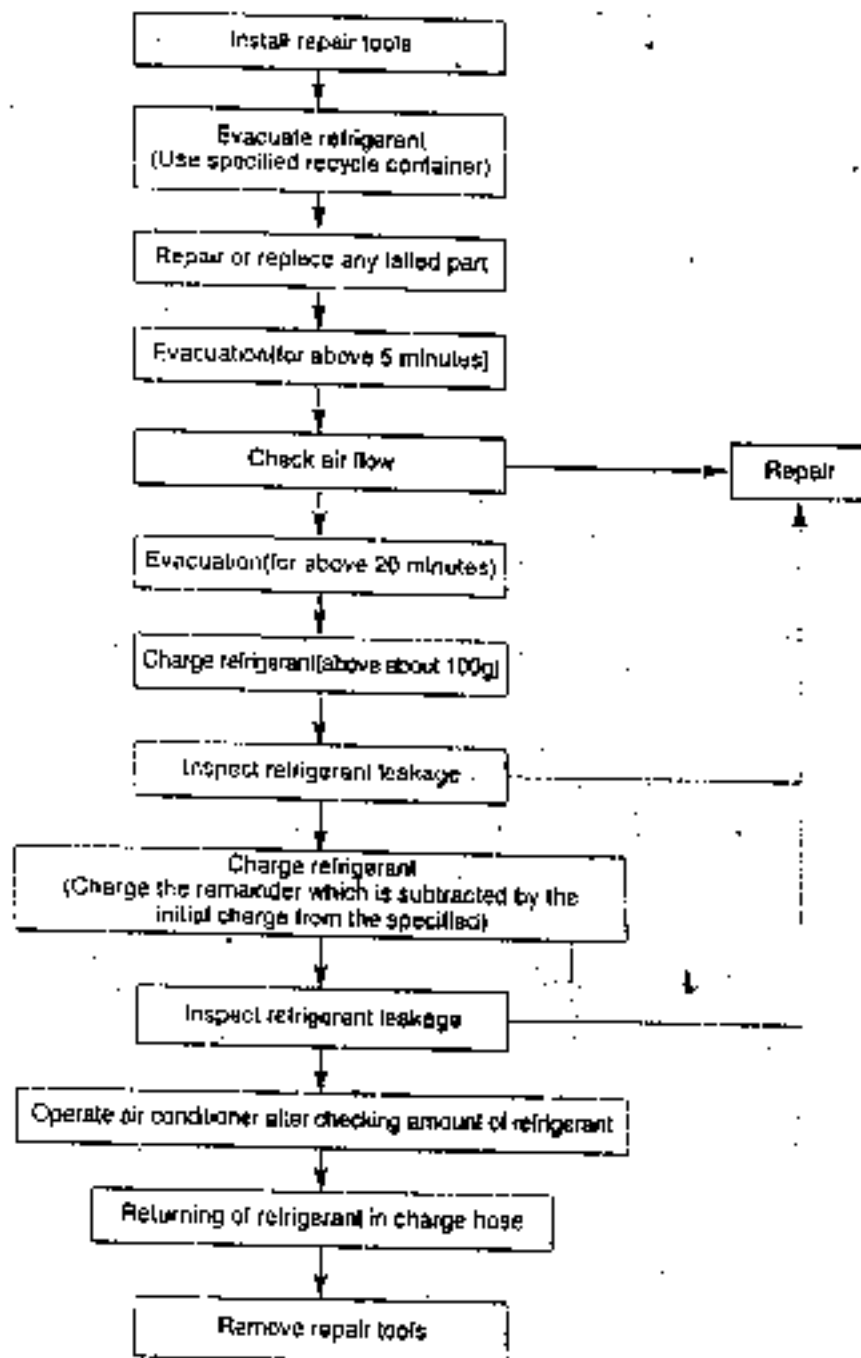

**DISCHARGING REFRIGERANT**

1. Connect the manifold gauge and the refrigerant discharger as shown in figure.

**Caution**

- Pay attention to misconnecting of the high and low pressure valve in reverse.

2. Evacuate the refrigerant gradually by opening the high pressure side valve slowly.

**Note**

- Open the valve slowly in order not to spray the compressor oil.

3. Open the low pressure side valve slowly if the manifold gauge is below 3.5 kg/cm<sup>2</sup> (50 psi, 343 kPa).

4. Open the both low and high pressure side valve slowly if the manifold gauge indicates 0 kg/cm<sup>2</sup> (0 psi, 0 kPa).

**Caution**

- Evacuate the refrigerant certainly into the specified container.

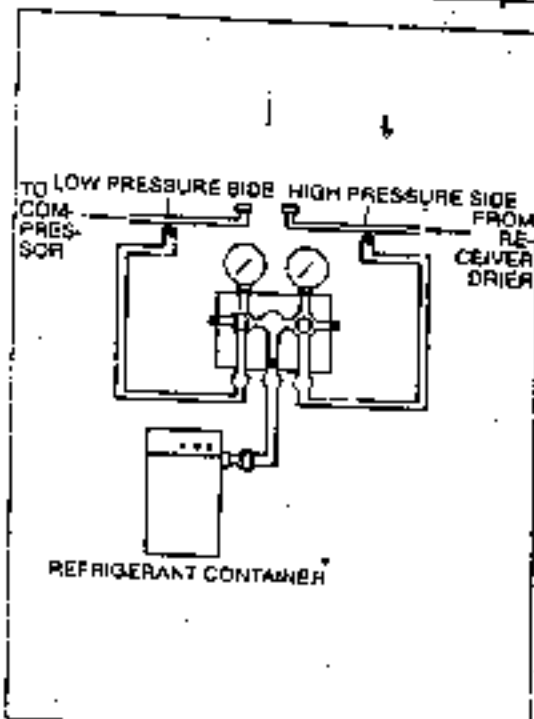

AN5062009

**EVACUATING SYSTEM**

**Evacuation**

**Note**

- Do the evacuation certainly if the air conditioner system is exposed under air.
- Do the evacuation for about 15 minutes after installing components, and for about 30 minutes if components is exposed under air after repair.

1. Connect the manifold gauge and the vacuum pump as shown in figure.
2. Open the both valves after operating the vacuum pump.
3. When the low pressure side gauge indicates about 710 mmHg (28 inHg 94 kPa), stop to operate the vacuum pump after closing the both valves.

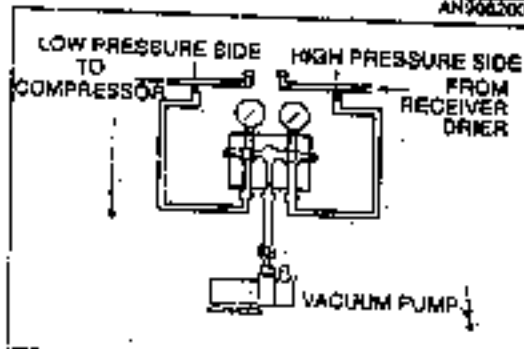

AN0062010

**Inspection Air Flow**

1. Inspect any pressure change at about 5 to 10 minutes after above evacuation step 3, and repair if necessary.

**Evacuation**

If no pressure change is found, evacuate for about 20 minutes again.

1. Open the both valves after operating the vacuum pump.
2. Continue to evacuate for about 20 minutes, until the low pressure side gauge indicates about 750 mmHg.
3. Stop to operate the vacuum pump after closing the both valves.

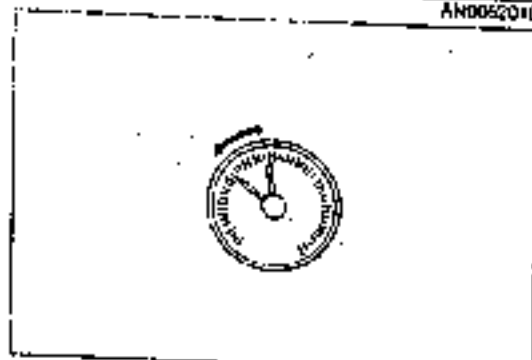

AN5062011

**Installation of Refrigerant Container**

1. Before connecting the valve to the refrigerant container, fully turn the handle in counterclockwise.
2. Turn in counterclockwise until the disc is positioned to the highest level.
3. Connect the center hose of manifold gauge to the connection and fully turn the disc in clockwise.
4. Turn the handle in clockwise until a hole can be generated on the sealed tab.
5. Turn the handle in counterclockwise so that the refrigerant flows into the center hose of manifold gauge. Do not open the high and low pressure valve at this time.
6. Evacuate air in hose by pushing the low pressure valve of the manifold gauge.

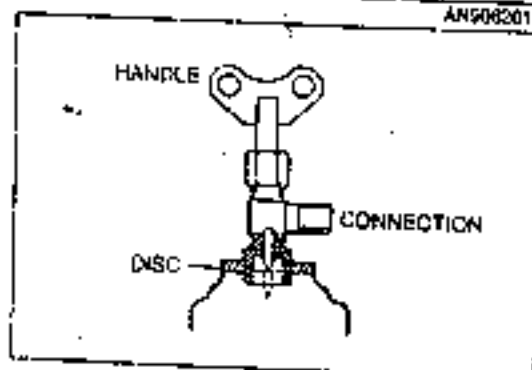

AN5062012



## LEAKAGE INSPECTION

## Note

- Inspect for leakage after evacuating.
1. After installing the refrigerant container, open the high pressure side valve of the manifold gauge set.
  2. Close the high pressure valve after charging the refrigerant, until the low pressure gauge indicates 1 kg/cm<sup>2</sup> (98 kPa, 14 psi)
  3. Inspect for leakage from each connection in system, by using the gas leakage detector.
  4. If any leakage is found, replace or repair after inspecting the O-ring status and the tightening torque of connection.
  5. If no leakage is found, continue to charge the refrigerant.

## Caution

- To have the correct leakage inspection, do it on place ventilated well.

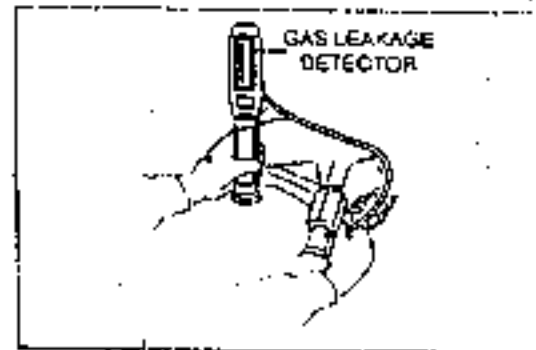

## Charging Refrigerant

1. Evacuate and inspect air flow, leakage.

## Note

- After charging about 100g of refrigerant at engine stop, charge an appropriate amount of refrigerant by using a pressure gauge during engine operation.
- When replacing the charging container, evacuate air in hose by pushing the low pressure side valve of the manifold gauge.

2. Open the low pressure side valve of the manifold gauge set and charge the refrigerant.

First refrigerant charging : 100g

3. If the refrigerant does not flow well in cycle, start engine and turn air conditioner on.
  - Temperature control lever : max. cool
  - Blower speed : 4th
  - Engine speed : 1300-1500 rpm

## Caution

- When charging the refrigerant during engine operation, charge with the refrigerant container stood up straightly, and do not open the high pressure side valve.

4. Open the low pressure side valve of the manifold gauge set and charge the specified amount of refrigerant.

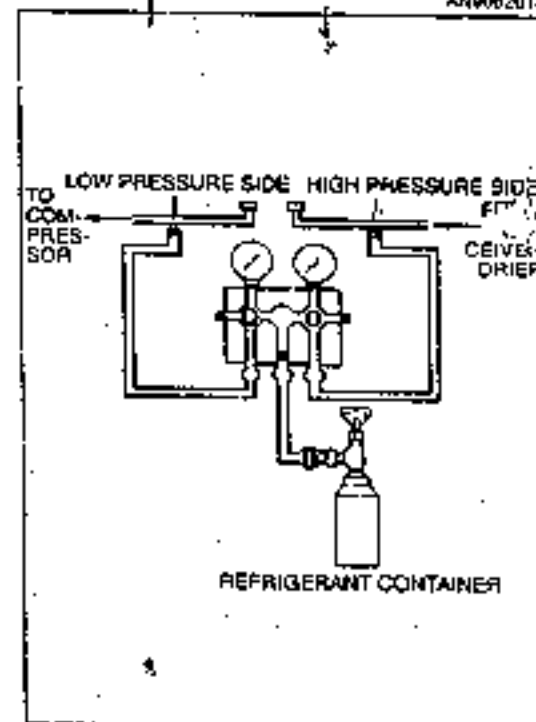

Vehicle	First refrigerant charging	Second refrigerant charging	Specified amount of refrigerant
12 seats coach	100g	1050g	1150 ± 50g
15 seats coach	100g	1200g	1300 ± 50g
Van	100g	700g	800 ± 20g

**Caution**

- Pay attention to the handle not to contact with water when the ambient temperature is low and charge after warming up the refrigerant container with above 40°C of warm water.
- When the ambient temperature is high, charge while cooling down the refrigerant container and the condenser etc.

**Warning**

- Do not directly heat up the refrigerant container or do not heat it to above 40°C (74°F).

**Note**

- Inspect the gauge pressure when the ambient temperature is 30~35°C (56~65°F).

**High pressure gauge :**1274~1950 kPa (13~20 Kg-cm<sup>2</sup>, 185~284 psi)**Low pressure gauge :**147~343 kPa (1.5~3.5 Kg-cm<sup>2</sup>, 21~50 psi)

5. Close the low pressure side valve.
6. Close the valve and the refrigerant container valve after stopping engine.

**Inspection of Refrigerant Leakage**

Clean the connection by clean clothes after finishing the refrigerant related work, and inspect any leakage at high pressure side by using a leakage detector.

**Note**

- Because the pressure of high pressure side decreases slowly and the pressure of low pressure side increases slowly if the circulation of refrigerant is stopped, the refrigerant leakage can be correctly detected by inspecting the high pressure side.

**INSPECTING PROCEDURES****High pressure side**

Compressor outlet → Condenser inlet → Receiver drier inlet → Cooling unit inlet

**Low pressure side**

Compressor inlet → Cooling unit outlet

**Compressor**

Inspect the shaft seal, bolt hole and magnetic clutch.

**Receiver Drier**

Inspect the D.P.S. and plug connection.

**Connection Valve**

Inspect all valve parts.

Inspect the anti-leakage cap is connected correctly.

Inspect any foreign material in cap.

**Inside of Cooling Unit**

Insert a leakage detector indicator into the drain hose immediately after stopping engine, and check for leakage (for above about 10 minutes).

**Note**

- When inspecting the inside of cooling unit, do it after ventilating, since the refrigerant can be leaked in the unit.

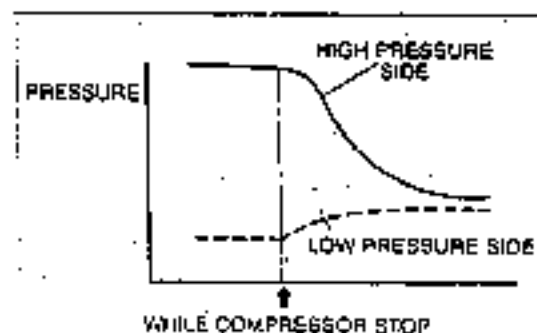

A149082015

inspection point

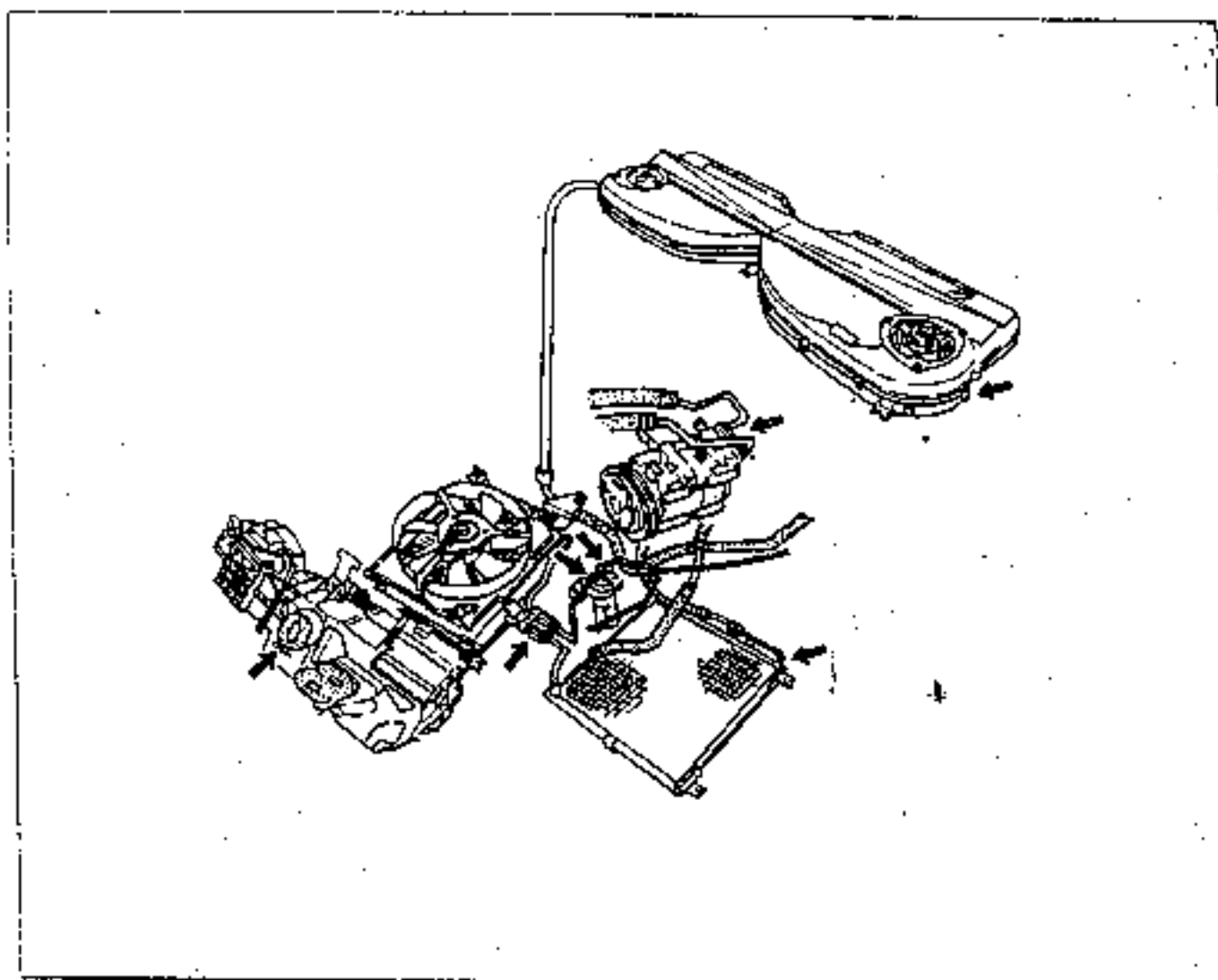

AN768201

## REMOVAL/INSTALLATION

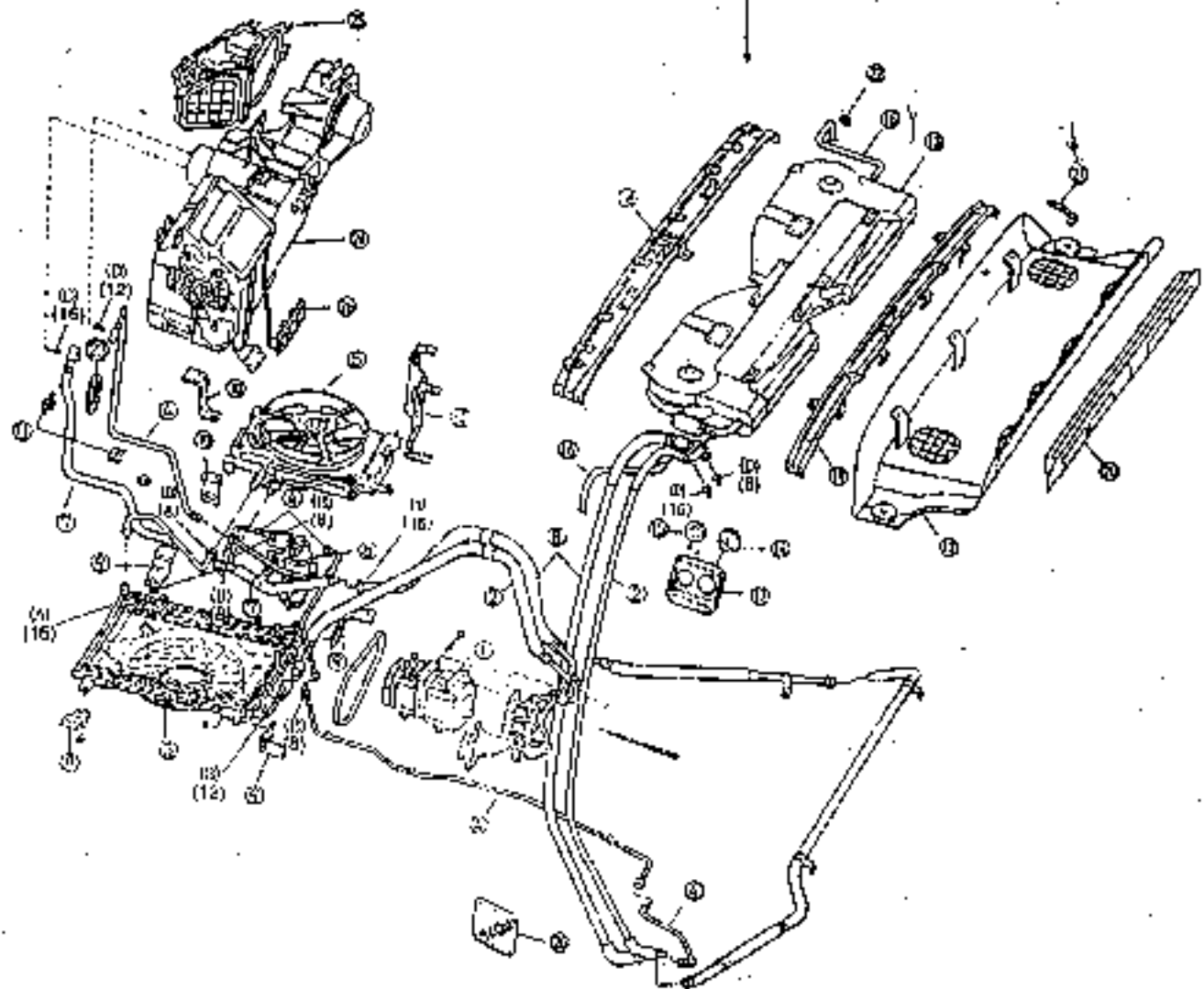
STRUCTURAL VIEW  
Front & Rear Cooler

( ) : TIGHTENING TORQUE NUMBER  
 ( ) : SIZE OF O-RING  
 (A): 2.0-3.0 kg-m  
 (B): 1.0-2.0 kg-m  
 (C): 0.3-0.4 kg-m  
 (D): 0.3-1.1 kg-m  
 (E): 1.0-1.2 kg-m

1. Compressor
2. Flexible hose(high pressure side)
3. Main condenser
4. Pipe(high pressure side)
5. Sub condenser
6. Receiver tank assembly
7. Pipe(low pressure side)
8. Flexible hose(low pressure side)

9. Main condenser bracket
10. Sub condenser bracket
11. Clip
12. Rear cooler cover
13. Rear cooler unit
14. Grommet(high pressure side)
15. Grommet(low pressure side)
16. Drain hose
17. Upper cover bracket
18. Front bracket assembly

19. Rear bracket assembly
20. Grille housing
21. Cover bracket(RH)
22. Grommet
23. Dash cover
24. Front HVAC unit
25. Intake duct
26. Front heater control assembly

AN9062017

## Heater

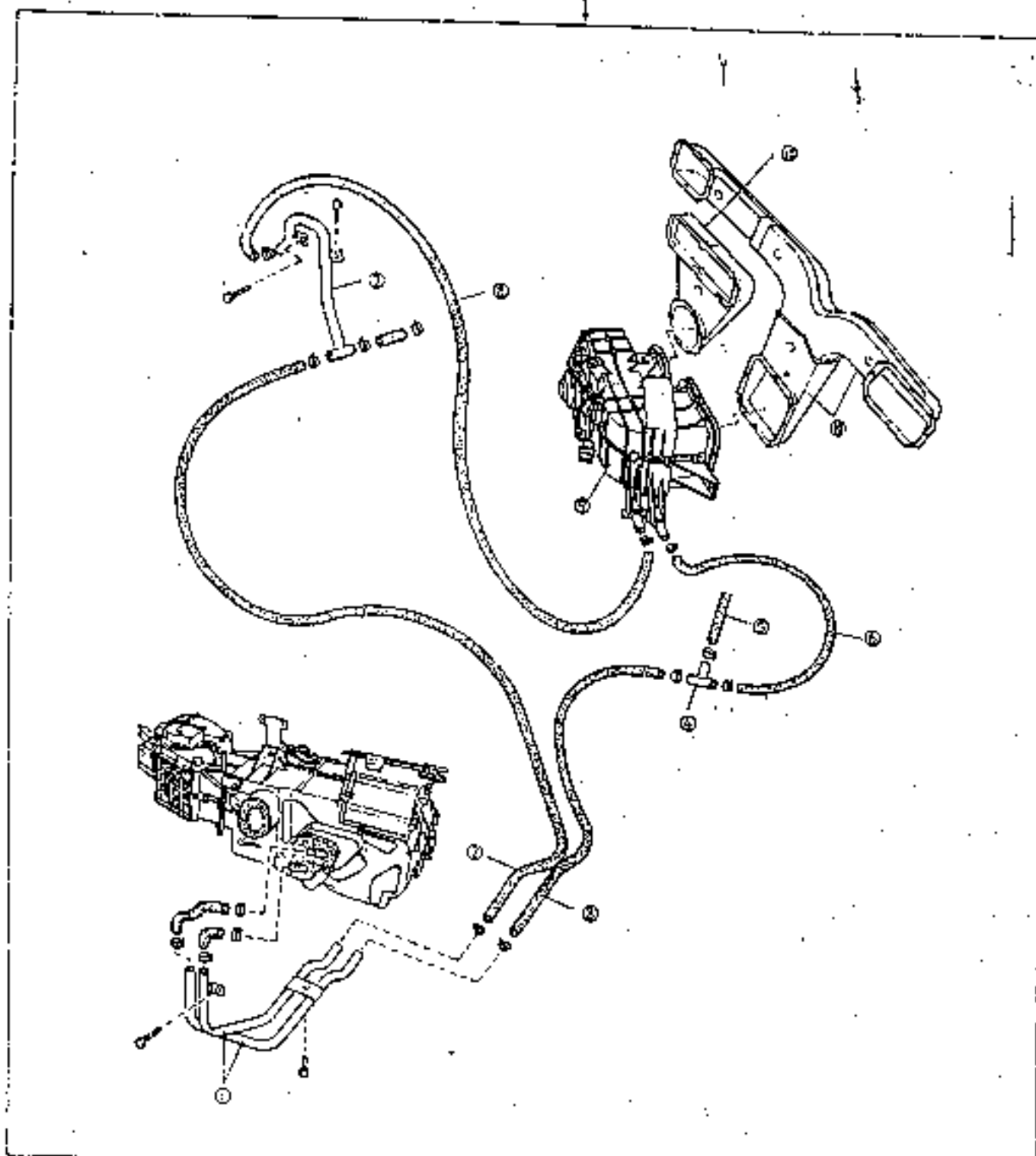

1. Front heater pipe assembly
2. Heater hose No.1
3. Heater hose No.2
4. Joint pipe
5. Heater hose No.4
6. Rear heater hose No.2

7. Front heater pipe assembly.
8. Rear heater hose No.1
9. Rear heater unit
10. Rear heater duct No.1
11. Rear heater duct No.2

**FRONT HEATER CONTROL ASSEMBLY**

**Removal note**

**Note**

- Remove the instrument panel (Refer to Section 60).
- Install in the reverse order of removal.

1. Remove the blower and mode lever connector after removing the lock bolt of front heater control assembly.
2. Remove the temperature control wire from the clip.

**Installation note**

1. Put the heat control lever on the maximum cooling position.
2. Fix the temperature control wire to the clip while pulling the temperature control lever up to the maximum cooling position.
3. Inspect the control lever for smooth moving, correct maximum cooling/heating position.

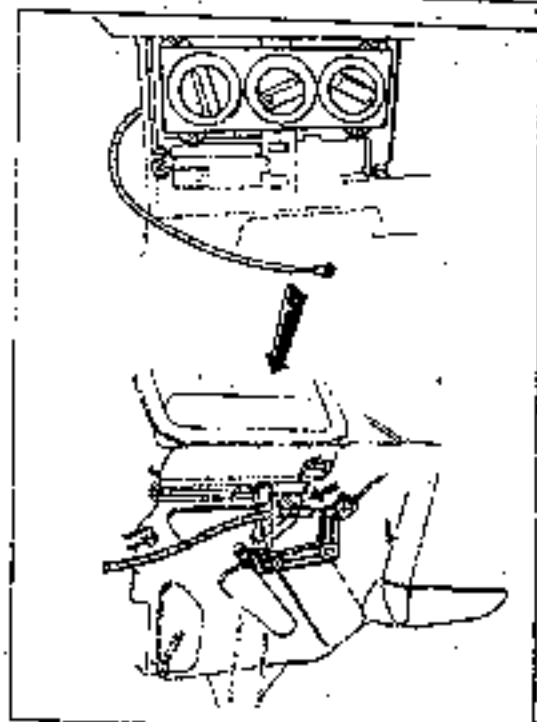

AN8062019

**HVAC UNIT**

**Removal note**

1. Drain the engine coolant.
2. Remove the instrument panel.
3. Do the refrigerant related work.
4. Install in the reverse order of removal.

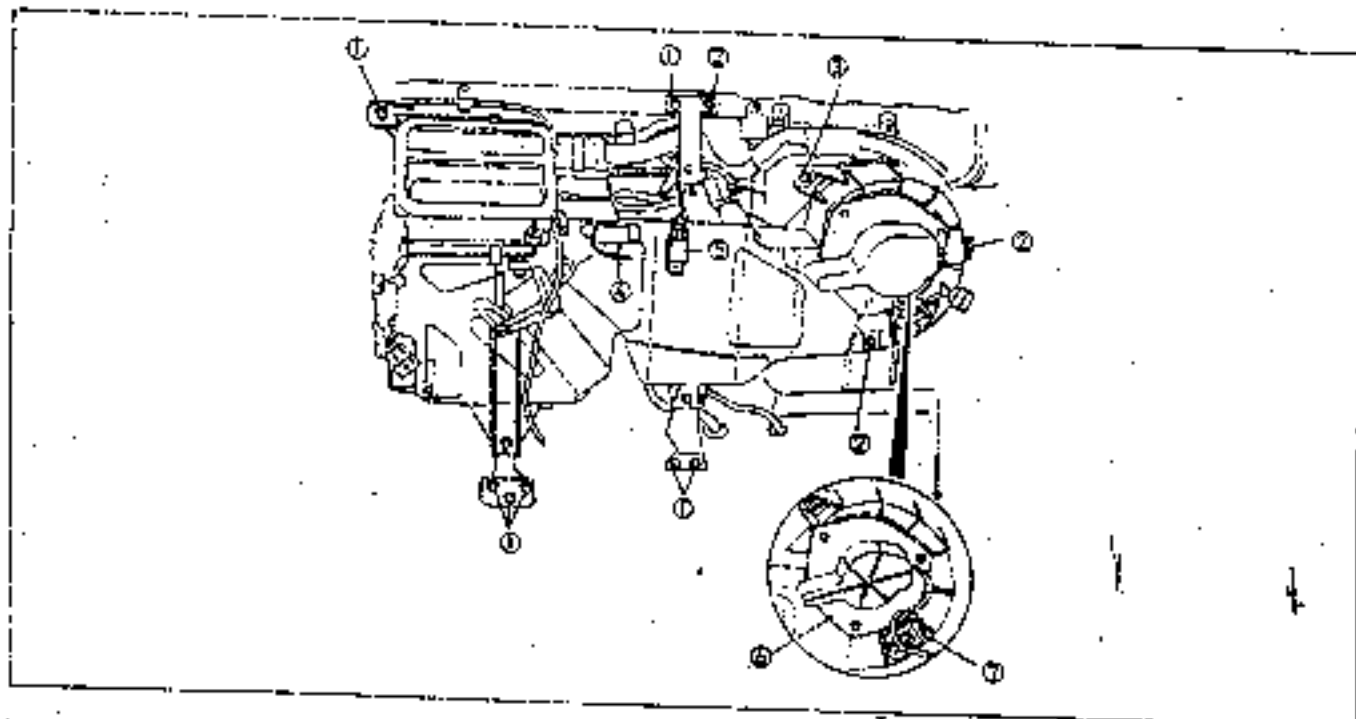

AI-9062020

- |  |                        |
|--|------------------------|
| 1. Bolt  | 5. Front air con relay |
| 2. Nut   | 6. Blower motor        |
| 3. Bolt (tightened with the intake duct assembly together) | 7. Resistor            |
| 4. Thermostat  |                        |

**Intake duct assembly**

1. Remove bolts and nuts as shown in the figure after removing the head lamp and shroud panel.
- ① Bolt (tightened with HVAC unit)
  - ② Bolt
  - ③ Nut
  - ④ Intake duct assembly

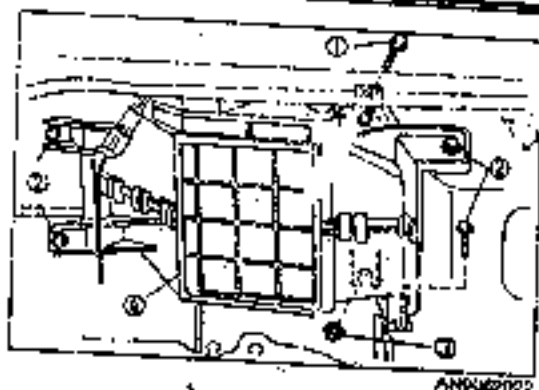

AN9062027

**COMPRESSOR**

**Removal note**

1. Remove the battery negative cable.
2. Remove the service cover. (Refer to Section 10)
3. After removing the magnetic clutch connector, remove the heater hose and alternator. (Refer to Section 32)

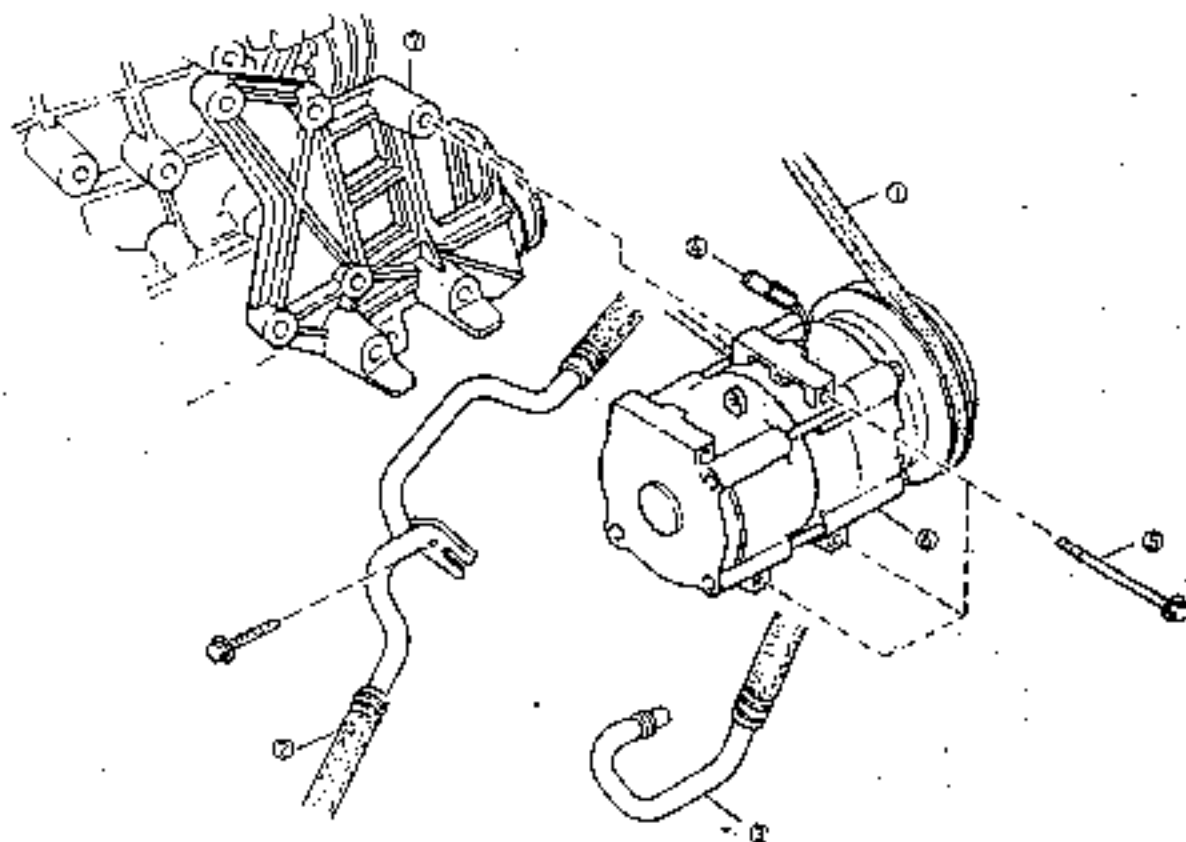

AN9062023

- 1. Drive belt
- 2. Low pressure hose
- 3. High pressure hose
- 4. Connector
- 5. Bolt
- 6. Compressor
- 7. Compressor bracket

## ADJUSTMENT OF TENSION

## Note

- New one means one used within 5 minutes.

1. Check the belt deflection by applying moderate pressure 10kg(98N) midway between the pulleys.

## Deflection

New one : 8~9 mm (0.31~0.35 in)

Used one : 9~10 mm (0.35~0.39 in)

2. If it is beyond specification, adjust the tension after loosening the mounting bolt (A) and turning the adjusting bolt (B).

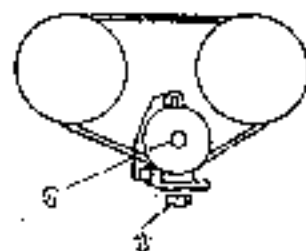

A48002022

## Handling of compressor oil

If the compressor oil is insufficient, it causes the compressor to be stuck due to the failure of lubrication, if it is too much, it causes the failure of cooling. In following case, inspect the oil amount, and replace or add it.

- When oil is leaked due to the refrigerant leakage in system.
- When the refrigerant leakage is suddenly discharged in system.
- When any related components is replaced.

## Caution

- The compressor oil for new refrigerant(R-134a) should be definitely used.
- Do not let moisture, dust or metal chip etc. of foreign material flow into.
- Store the compressor oil in a steel can, in order to avoid moisture intrusion (Do not use any poly-container).
- Plug any opening with cap or vinyl tape immediately after replacing components.
- Add following amount of the compressor oil when replacing the related components.

Replaced components	Amount of oil(cc)
Condenser	50
Cooling unit(Evaporator core)	30
Receiver drier	30
Refrigerant piping	10

## Caution

- Before replacing components, do operation for returning oil. (Refer to page 62-11)

If the compressor is replaced, evacuate following amount of the compressor oil from the new compressor and add the remainder.

Oil amount : 265 -

(Amount left in old compressor + (15~20))



## TROUBLESHOOTING GUIDE

## INSPECTION OF REFRIGERANT PRESSURE

1. Open all doors and windows in service area.
2. Install the manifold gauge set.
3. Start engine and keep the speed at 2,000 rpm.
4. After turning the air conditioner on, keep it at about 18°C.
5. Inspect the high and low refrigerant pressure.
6. Check if the high and low refrigerant pressure keep status as shown in the figure.

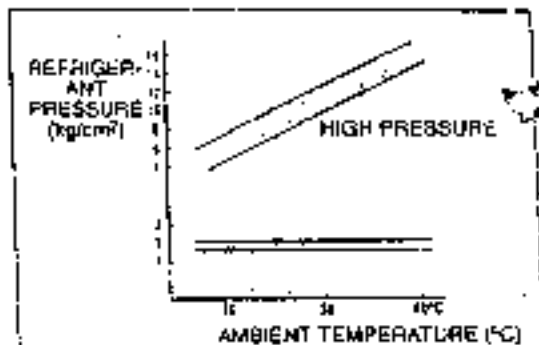

AH0082025

Step	Inspection	Yes	Actions
1 High pressure side : 6.0~10.0(kg/cm²)(114~142psi), Low pressure side : 1.0(kg/cm²)(14psi)			
[Troubleshooting hint]			
• Insufficient refrigerant			
1	Inspect leakage of refrigerant or contamination at the pipe connection.	Yes	Tighten again. (Refer to page 62-15)
		No	Go to next step
2	Inspect leakage of refrigerant in pipe and refrigerant system by using a leakage detector.	Yes	Repair the leakage.
		No	System is OK. Add refrigerant.

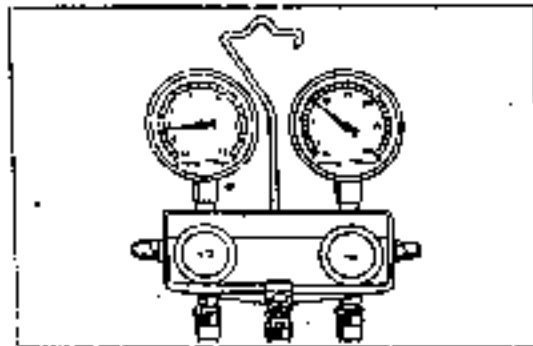

AH0082026

Step	Inspection	Yes	Actions
2 High pressure side : above 23(kg/cm²)(327psi), Low pressure side : about 2.5~3.0(kg/cm²)(35psi)			
[Troubleshooting hint]			
• Overcharged refrigerant • Frozen condenser			
1	Inspect the condenser fan for any the condenser distortion or contamination	Yes	Clean, repair or replace.
		No	Refrigerant is overcharged.

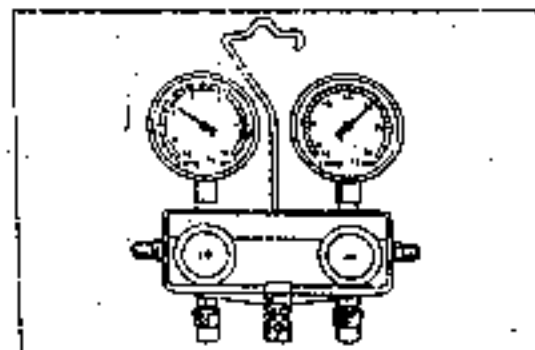

AH9002027

3	High pressure side : about 20-25kg/cm <sup>2</sup> (320psf), Low pressure side : 2.5-3.5kg/cm <sup>2</sup> (36psf)
[Troubleshooting hint]	
• Air in system	
Discharged refrigerant → Vacuum → Charge refrigerant (Refer to page 62-11)	
Note	
• When it is operated with air in system for a long time, repair the receiver drier and replace if necessary.	

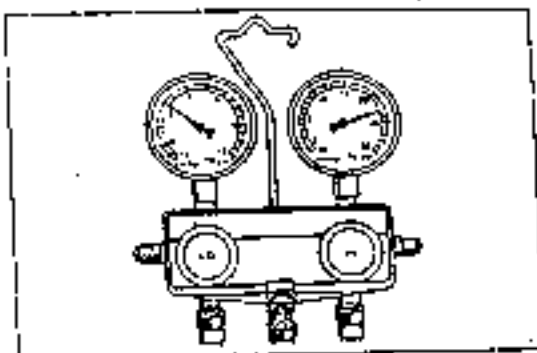

AN9062028

4	High pressure side : above 6kg/cm <sup>2</sup> (85psf), Low pressure side : about 700mmHg (vacuum)	
[Troubleshooting hint]		
• Refrigerant gas is not circulated.		
Step	Inspection	Actions
1	<ul style="list-style-type: none"> <li>After installing the manifold gauge, start engine.</li> <li>Turn the air conditioner on.</li> <li>Set the blower switch to 3-speed.</li> <li>After turning the air conditioner off, wait for 10 minutes.</li> <li>Measure the high and low pressure again after 5 minutes, and check if it indicates to normal pressure.</li> </ul> <p>High pressure : 130-140kg/cm<sup>2</sup> Low pressure : 15-22kg/cm<sup>2</sup></p>	<p>Yes</p> <p>Moisture in system Replace the receiver drier.</p> <p>No</p> <p>Foreign material in system. Replace the expansion valve.</p>

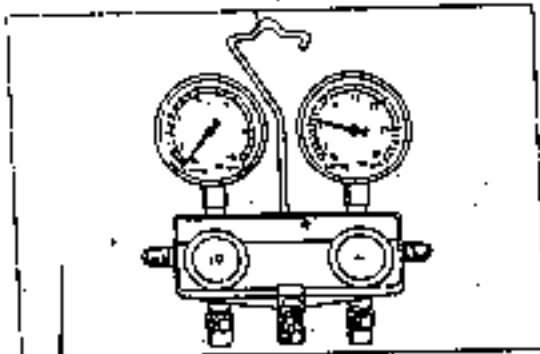

AN9062029

5	High pressure side : 6-13kg/cm <sup>2</sup> (90-250psf), Low pressure side : 500mmHg (vacuum) (without needle)
[Troubleshooting hint]	
• Refrigerant gas is not circulated because the expansion valve is frozen due to moisture in system.	
Caution	
• Inspect the pressure of refrigerant carefully, because the pressure can be normally indicated when moisture in system is frozen.	
Discharged refrigerant → Vacuum → Charge refrigerant	
Note	
• If the pressure is not good even after refrigerant related work, Replace the receiver drier.	

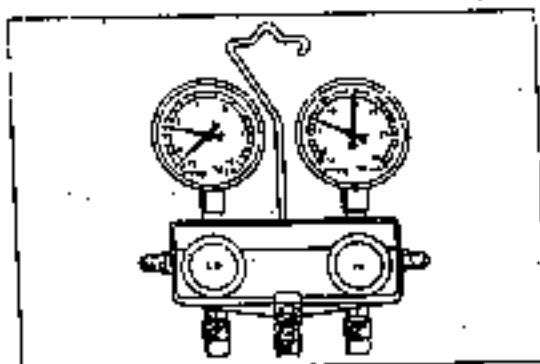

AN9062030

6 High pressure side: 22.0-23.0kg/cm <sup>2</sup> (313-327psi), Low pressure side: 2.5kg/cm <sup>2</sup> (36psi)			
[Troubleshooting hint]			
• The pressure of refrigerant has problem due to failure of the expansion valve or sensing bulb.			
Step	Inspection	Actions	
1	Inspect the installation of sensing bulb.	Yes	Replace the expansion valve.
		No	Repair or adjust it.

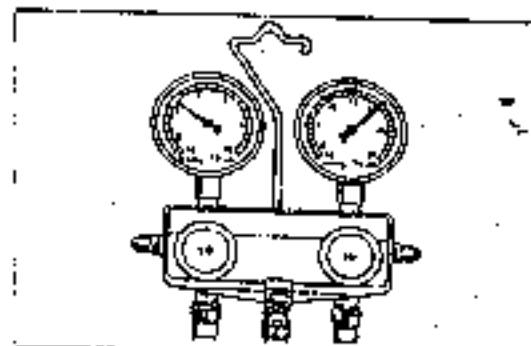

AN9062031

7 High pressure side: 7.0-11.0kg/cm <sup>2</sup> (100-156psi), Low pressure side: 4.0-6.0kg/cm <sup>2</sup> (57-86psi)		
[Troubleshooting hint]		
• The pressure of refrigerant has problem due to insufficient compression of compressor.		
Inspect the compressor and replace if necessary.		

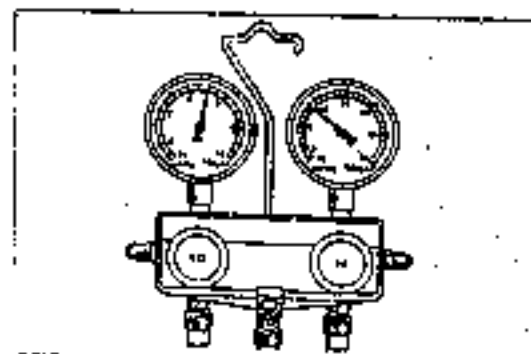

AN9062032

## INSPECTION

## HVAC BLOWER MOTOR

1. Check if the circuit between the terminal A and E is closed, with the ignition switch OFF.
2. Measure the resistance between the terminal A and B.  
Resistance : 0-5  $\Omega$
3. Measure the resistance between the terminal A and C.  
Resistance : 1-3  $\Omega$
4. Measure the resistance between the terminal A and D.  
Resistance : 2-5  $\Omega$

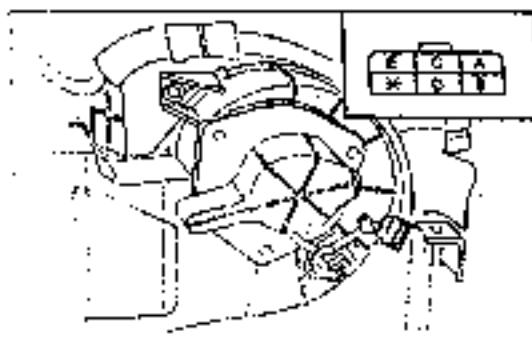

AN9062033

## FRONT AIR CON RELAY

1. Check if the circuit between the terminal A and E is closed, with the ignition switch OFF.
2. After applying 12V of voltage between the terminal A and E, check if the battery voltage appears on between the terminal B and body.
3. After applying 12V of voltage between the terminal A and E, check if the battery voltage appears on between the terminal C and body.

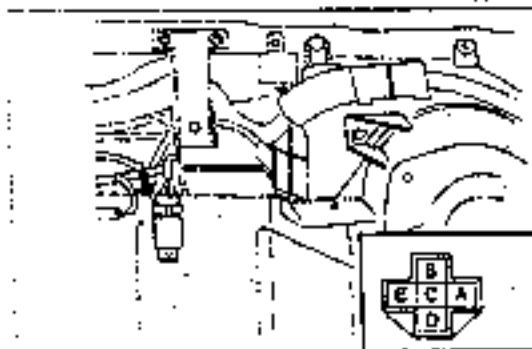

AN9062034

## INTAKE ACTUATOR

1. After applying battery voltage between the (+) terminal of C and (-) terminal of A, check if the intake actuator rotates in fresh mode.
2. After applying battery voltage between the (+) terminal of C and (-) terminal of B, check if the intake actuator rotates in recirculation mode.

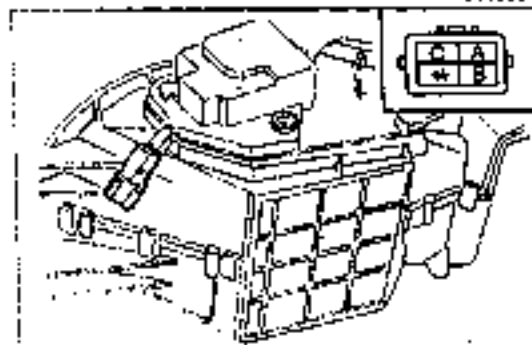

AN9062035

## MAIN CONDENSER

1. Check if the circuit between the terminal A and B is closed, with the ignition switch OFF.

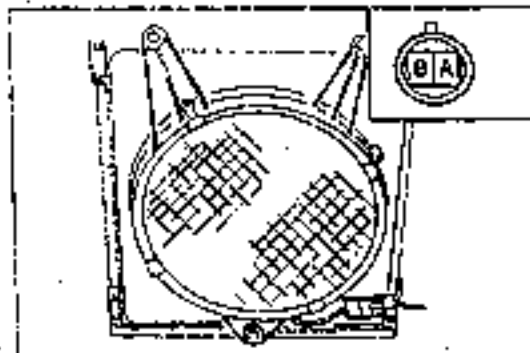

AN9062036

## SUB CONDENSER

1. Check if the circuit between the terminal A and B is closed, with the ignition switch OFF.

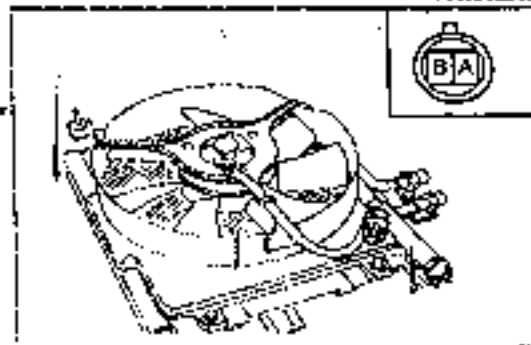

AN9062037

**REAR HEATER RELAY, BLOWER MOTOR AND RESISTOR ASSEMBLY**

1. Check if the circuit between the terminal B and C is closed, with the ignition switch OFF.
2. Measure the resistance between the terminal D and E by using an ohmmeter.

Resistance : 0~6  $\Omega$ 

3. Measure the resistance between the terminal D and F by using an ohmmeter.

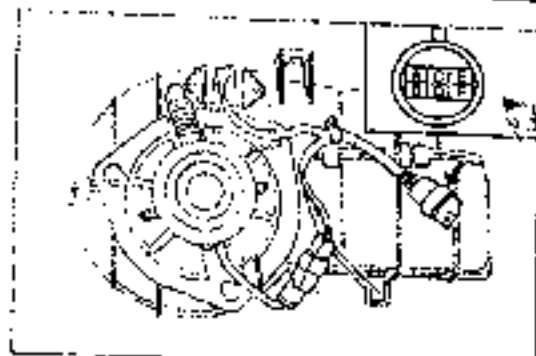
Resistance : 1~9  $\Omega$ 

AN9062030

**MODE ACTUATOR**

1. After applying battery voltage to B terminal (+) and D, F terminal (-), check if it rotates in the vent mode.
2. After applying battery voltage to B terminal (+) and D, H terminal (-), check if it rotates in the bi-level mode.
3. After applying battery voltage to B terminal (+) and D, A terminal (-), check if it rotates in the heat mode.
4. After applying battery voltage to B terminal (+) and D, C terminal (-), check if it rotates in the def / heat mode.
5. After applying battery voltage to B terminal (+) and D, G terminal (-), check if it rotates in the def mode.

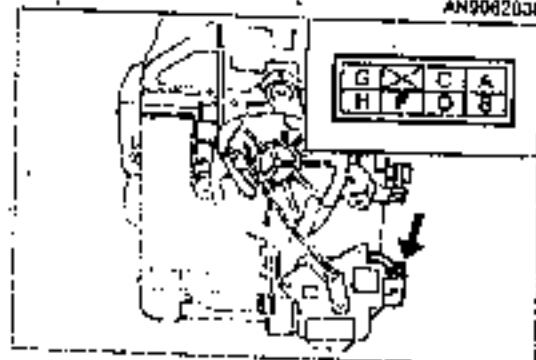

AN9062050

**DUAL PRESSURE SWITCH**

1. After connecting the manifold gauge set, check if the pressure of high pressure side indicates 2.1~21 kg/cm<sup>2</sup> (30~299 psi).
2. After disconnecting the dual pressure switch connector, check if the circuit between two terminals is closed.
3. If it is not closed, replace the dual pressure switch.

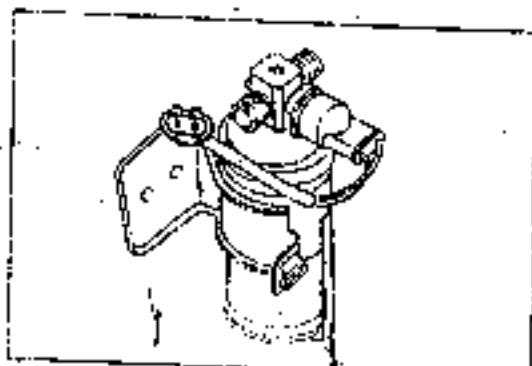

AN9062040

**Note**

- In order to protect a component, turn the magnetic clutch off if the pressure of refrigerant is abnormally high (3136 ± 186 kPa, 32 ± 2 kg / cm<sup>2</sup>, 455 ± 28 psi) or low (186 ± 20 kPa, 2 ± 0.2 kg / cm<sup>2</sup>, 28 ± 2.8 psi).

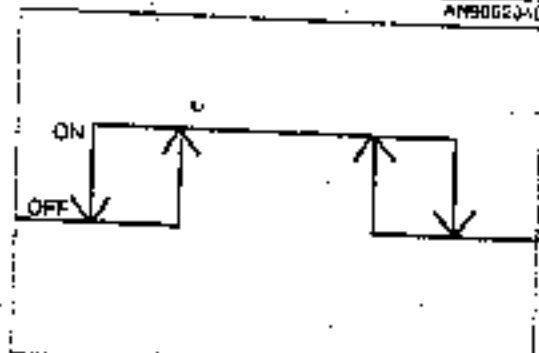

AN9062041

**THERMOSTAT**

1. After putting the sensing bulb into water, inspect the continuity at above 4°C(39°F) and replace the thermostat if necessary.

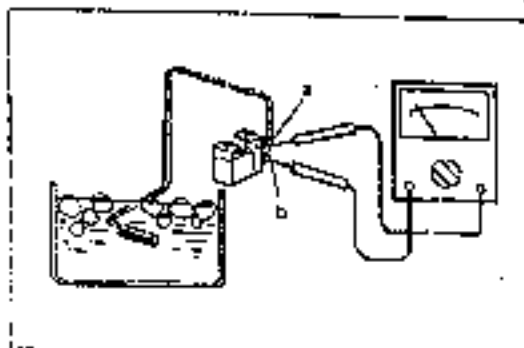

AN9052071

**INSTALLATION POSITION OF THERMOSTAT**

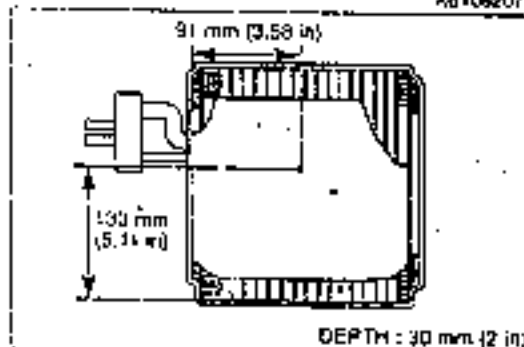

DEPTH : 30 mm (2 in)

AN9062044

**COMPRESSOR**

**Clearance**

Measure the clearance between the pressure plate and the rotor pulley in following steps.

1. Put the compressor onto the block gauge.
2. After putting the dial gauge indicator onto the pressure plate, measure the clearance between the pressure plate and the pulley with the battery voltage applied.

Clearance :  $0.5 \pm 0.2$  mm ( $0.02 \pm 0.008$  in)

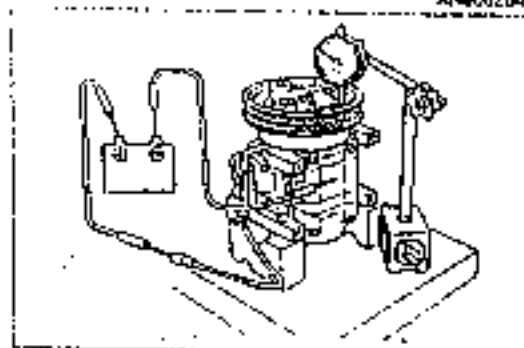

AN9052045

**MAGNETIC CLUTCH**

1. Inspect the continuity between each terminal of the stator.
2. Replace the stator if it is not closed.

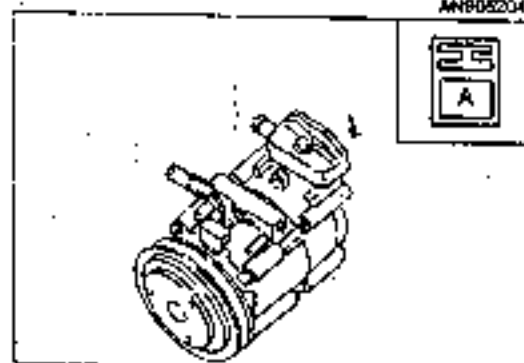

AN9062046